



# HENDI

2024 | Tools for Chefs



Partener al echipei  
nationale a bucatarilor



Vizualizeaza  
catalogul online

tel.: 0738 726 775 • [www.hendi.ro](http://www.hendi.ro)

TAVI GASTRO-  
NORM GN



CUTITE  
SI ACCESORII



COFETARIE,  
PATISERIE  
SI CAFENEA



ECHIPAMENTE  
PROCESARE



ECHIPAMENTE/  
ACCESORII DE  
VIDAT



ECHIPAMENTE  
BUCATARIE  
CALDA



CUPTOARE  
PROFESIONALE  
COMBI-STEAMER



PIZZA, PASTE,  
KEBAB



ECHIPAMENTE  
FRIGORIFICE



THERMOBOX,  
RAFTURI,  
CARUCIOARE



PORTELAN,  
TACAMURI,  
ARTICOLE MASA



COMBUSTIBIL,  
BUFET



BAR



EXPRESOARE  
SI ACCESORII



MASINI DE  
SPALAT VASE



MOBILIER  
INOX



GRILL-URI  
SI LAMPI  
DE INCALZIRE







# HENDI

Tools for Chefs

Echipamente si accesorii  
profesionale pentru  
industria horeca

CATALOG **2024**



## Hey, Chef!

Indiferent care este rolul tau in industria gastronomică - fie ca esti bucatar, proprietar de restaurant, manager de cantina sau cofetar - noi suntem gata sa te inspiram intotdeauna.

HENDI ofera aproape 5000 de produse printre care si cateva sute de produse noi. In acest fel, oferta noastra actualizata constant raspunde nevoilor in continua schimbare ale pietei.

Explorati acest catalog si descoperiti produsele noastre Tools for Chefs!





# HENDI

Tools for Chefs



Vezi filmul

## ■ HENDI Romania

Str. Sânzieni FN, DE 305  
507075, Ghimbav, Braşov

T: +40 268 320330  
F: +40 268 320335

contact.ro@hendi.eu  
www.hendi.ro

## ■ HENDI Olanda

Steenoven 21, 3911 TX Rhenen  
The Netherlands  
T: +31 (0)317 68 10 40  
F: +31 (0)317 68 10 45  
info@hendi.eu  
www.hendi.com

## ■ HENDI Austria

Gewerbegebiet Ehring 15  
5112 Lamprechtshausen, Austria  
T: +43 (0) 6274 200 10 0  
F: +43 (0) 6274 200 10 20  
office.austria@hendi.eu  
www.hendi.com

## ■ HENDI Polonia

ul. Firmowa 12,  
62-023 Robakowo  
Poland  
T: +48 61 658 70 41  
export@hendi.pl  
www.hendi.com

## ■ HENDI Grecia

5 Metsovou Str.  
18346 Moschato, Athens,  
Greece  
T: +30 210 483 97 00  
F: +30 210 483 97 10  
office.greece@hendi.eu  
www.hendi.com

## ■ HENDI Italia

Via Leonardo da Vinci 4,  
39100 Bolzano (BZ) Italia  
T: +39 800727483  
office.italy@hendi.eu  
www.hendi.com

## ■ HENDI Hong Kong

1208, 12/F, Exchange Tower  
33 Wang Chiu Road, Kowloon Bay  
Hong Kong  
info-hk@hendi.eu  
www.hendi.com

## ■ HENDI Spania

Polígono Campollano Calle B, 120  
02007 Albacete, Spania  
T: +34 967 48 61 93  
espana@hendi.eu  
www.hendi.com

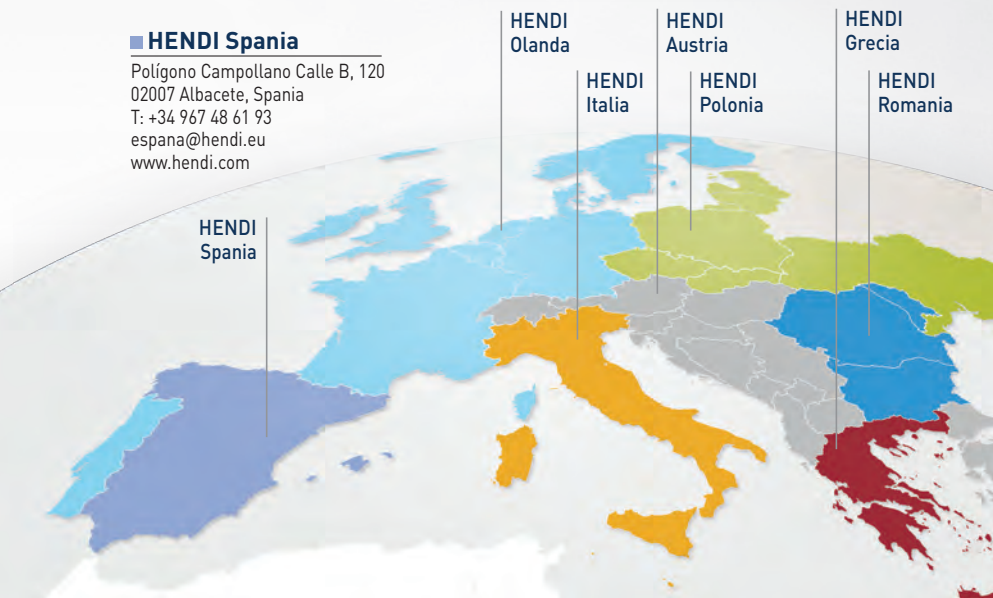



design by  
Robert Bronwasser



Lucram impreuna cu designerul olandez **Robert Bronwasser**. Datorita lui, echipamentele noastre estetice, originale si functionale au un design cu adevarat unic. Colectia noastra de produse **HENDI proiectate de Robert Bronwasser** este in continua crestere!

*„Ceea ce este crucial in colaborarea mea cu HENDI este imbinarea functionalitatii si ergonomiei echipamentului cu o forma intriganta si interesanta, astfel incat bucatarii sa se bucure de toate aceste aspecte si sa recunoasca imediat produsele noastre. Folosim designul intr-un mod care sa usureze munca*

*bucatarilor si sa le permita sa se concentreze pe prepararea unor mancaruri extraordinare, mai degraba, decat pe operarea echipamentului.”*



# CUNOASTE LINIILE DE PRODUSE HENDI - Profi, Kitchen si Budget Line

Fiecare dintre cele 3 linii sunt create cu un scop diferit – se pliaza pe toate nevoile si asteptarile bucatarilor, lucratorilor din gastronomie sau pasionatilor de gatit.



## PROFI LINE

**Un partener pentru profesioniști** – construcție bine gândită și solidă, materiale și componente de cea mai înaltă calitate  
Utilizare intensivă 24/24.  
Garantie pe termen lung și ușurință în întreținere pentru a reduce costurile și a maximiza eficiența energetică.

## KITCHEN LINE

**Un asistent solid pentru toate locațiile HORECA.**  
O linie realizată din materiale standardizate, de înaltă calitate la un preț rezonabil.  
Concepută pentru utilizare echilibrată, garantează rezultate fiabile și ușurință în întreținere pentru a reduce costurile și a maximiza eficiența energetică.

## BUDGET LINE

**Ajutor eficient în bucatăriile casnice și profesionale.**  
Materiale economice.  
- perfecte pentru o utilizare zilnică dar nu intensivă.  
Forma gândită pentru mod de lucru simplu și facil.

**Toate liniile respecta standardele europene de siguranță și utilizare.**





## VIZITEAZA MAGAZINUL HENDI

- ✓ Program avantajos
- ✓ Locuri de parcare
- ✓ Mai mult de 3500 de produse disponibile la raft
- ✓ Garantie 12 luni pentru produse cu alimentare electrica si gaz
- ✓ Afișaj de neegalat al cutitelor
- ✓ Prezentare exceptionala a portelanului Fine Dine
- ✓ Distribuitor autorizat Grafen, Dexion, Tecnoeka, Dihr, Vega, Prismafood
- ✓ Consultanta de specialitate
- ✓ Posibilitatea de a procesa comenzi prin telefon si e-mail
- ✓ Livrare gratuita la comenzi peste 1500 RON

### Oferim echipamente profesionale pentru:



restaurante / baruri



bistro



pizzerii



cofetării



patiserii



cafenele



gelaterii



institutiile publice



magazine



stații de alimentare



food truck



cantine



### Otopeni

Calea Bucuresti nr. 242, Ilfov

Telefon: 0724235863

Email: magazinotopeni@hendi.eu



Vizualizeaza traseu

### Bucuresti

Nerva Traian nr. 3

Telefon: 0722361238

Email: magazinerva@hendi.eu



Vizualizeaza traseu

Transport gratuit la comenzi peste 1500 RON.

# HENDI SUSȚINE ECHIPA NAȚIONALĂ DE BUCĂTARI



## ANUL 2024 – ANUL JOCURILOR OLIMPICE CULINARE PENTRU ASOCIAȚIA NAȚIONALĂ A BUCĂTARILOR ȘI COFETARILOR DIN TURISM DIN ROMÂNIA – A.N.B.C.T.

De aproape 125 de ani, această competiție reunește bucătari talentați, ce se întrec în creativitate și abilitate, aducând pe masă o multitudine de arome și texturi care captează simțurile și imaginația. Se poate spune astfel că la Olimpiada Culinară de la Stuttgart 2024 nu doar că s-a sărbătorit măiestria culinară, ci s-au setat trenduri, s-a inovat și s-au stabilit standarde de excelență în bucătăria mondială. Este un eveniment unde tradiția se întâlnește cu inovația, unde fiecare bucătar aduce un omagiu bogăției gastronomice globale.

Echipele naționale de bucătari ale României, atât de seniori, cât și de juniori, sunt formate din membri ai Asociației Naționale a Bucătarilor și Cofetarilor din Turism, având fiecare propria abordare. Echipa de seniori este condusă de Emanuel Mocan, multiplu câștigător a numeroase competiții naționale și internaționale, iar cea de juniori este sub îndrumarea căpitanului Munteanu Dadiana, câștigătoare a competiției Arena Bucătarilor.



**Echipa națională de seniori:** Emanuel Mocan (Căpitan), Marinică Bejenaru, Marian Zăncianu, Alexandru Vreme, Alin Murariu, Georgian Țufa, Daniel Nistor, Florin Ciobanu, Mihai Ciprian Necula, Flavian Dobre și Dragoș Bercea (Manager Echipă).

**Echipa națională de juniori:** Munteanu Dadiana (Căpitan), Paul Antohi, Filip Adam, Mihai Petre, David Toader, Andreea Buzatu, Andrei Miron și Bogdan Cozma (Manager Echipă).

Ediția din 2024 a adus numeroase medalii pentru gastronomia românească. Palmaresul echipelor naționale ale României a fost dat de 2 medalii de argint la Restaurantul Națiunilor și Chef's Table pentru echipa de seniori, respectiv

2 medalii de bronz la Restaurantul Națiunilor și Chef's Table pentru echipa de juniori. Prima participare a României la acest concurs a avut loc în anul 1972 și a fost reprezentată de o echipă mixtă formată din maeștrii bucătări din Capitală și Brașov, condusă la acea vreme de către Dumitru Burtea, Președinte de Onoare al ANBCT și Membru de onoare al World Association of Chefs Societies – WACS. În momentul de față, asociația națională este condusă de un Consiliu Director format din: Presedinte: Chef Ștefan Bercea  
Secretar general: Lady Chef Cornelia Ghișoi  
Trezorier: Chef Nicolae Busu



# DEPARTAMENT VANZARI HENDI ROMANIA

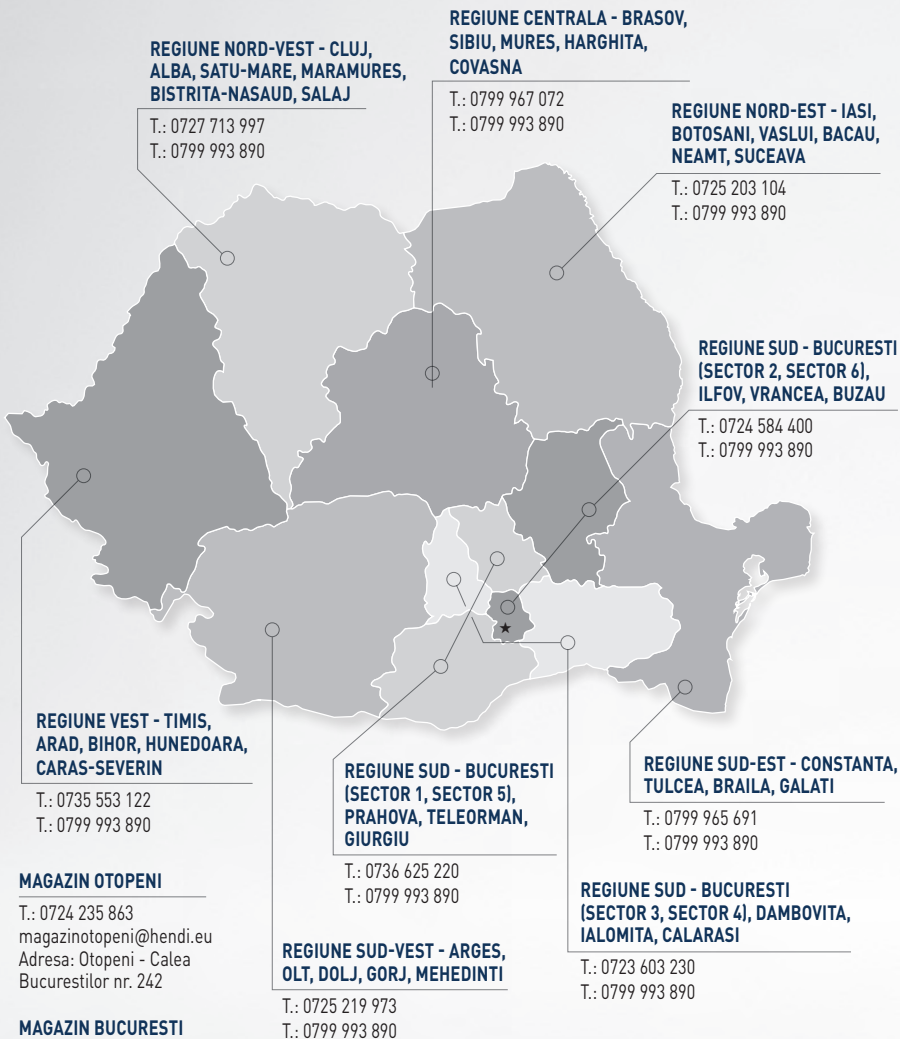

## MAGAZIN OTOPENI

T.: 0724 235 863  
magazinotopeni@hendi.eu  
Adresa: Otopeni - Calea Bucurestilor nr. 242

## MAGAZIN BUCURESTI

T.: 0722 361 238  
magazinnerva@hendi.eu  
Adresa: Bucuresti  
Nerva Traian nr. 3



TAVI GASTRO-NORM GN

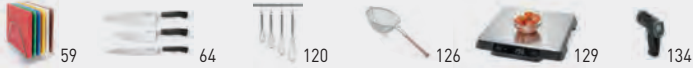

CUTITE SI ACCESORII



COFETARIE, PATISERIE SI CAFENEA



ECHIPAMENTE PROCESARE

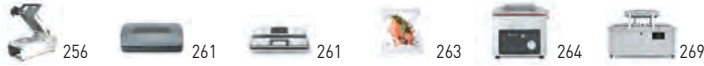

ECHIPAMENTE/ACCESORII DE VIDAT



ECHIPAMENTE BUCATARIE CALDA



CUPTOARE PROFESIONALE COMBI-STEAMER



PIZZA, PASTE, KEBAB



ECHIPAMENTE FRIGORIFICE

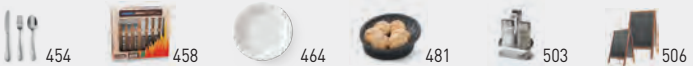

THERMOBOX, RAFTURI, CARUCIOARE



PORTELAN, TACAMURI, ARTICOLE MASA

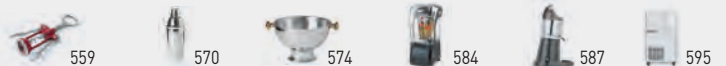

COMBUSTIBIL, BUFET



BAR

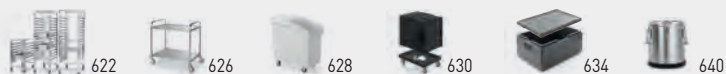

EXPRESOARE SI ACCESORII



MASINI DE SPALAT VASE

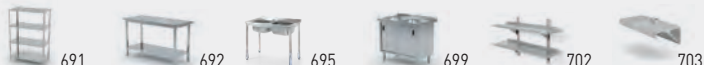

MOBILIER INOX



GRILL-URI SI LAMPI DE INCALZIRE



# Selectie articole noi 2024

Oala din fonta  
pagina 33



Tigaie grill  
din fonta  
pagina 33



Piatra de ascutit  
japoneza  
pagina 91



Cutie depozitare oua  
HENDI OVOBOX 120  
pagina 53



Tocator din fibra  
de lemn  
pagina 63



Set de cutite - 4 bucati  
pagina 81



Manusa de protectie  
impotriva taierii  
pagina 92



Secure pentru  
carne  
pagina 102



Bol de amestecare  
cu baza din silicon  
pagina 122

**NOU**

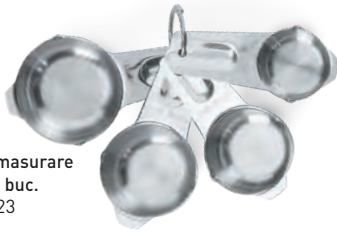

Cupe de masurare  
- set de 4 buc.  
pagina 123



Mandolina  
japoneza  
Samurai  
pagina 94



Mandoline japoneze  
HENDI Shōgun 将軍  
pagina 97



Termometru  
digital  
cu sonda  
pliabila  
pagina 134



Temporizator dubla  
pagina 136



Cana pentru  
cernerea  
fainii  
pagina 177



Tava de racire  
pentru prajituri  
pagina 177

Sucitor din lemn  
pagina 179



## Selectie articole noi 2024



Unitate motor  
pentru blenderele  
stick Kitchen Line  
pagina 247

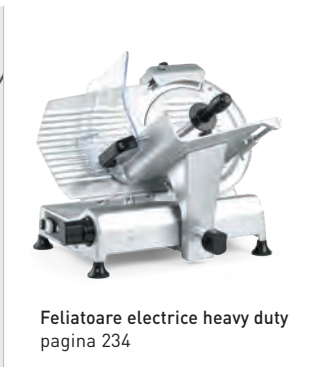

Feliatoare electrice heavy duty  
pagina 234



Blender vertical Smart  
Pressure fara cablu  
pagina 249



Set 3 accesorii pentru paste  
pentru mixerul planetar  
HENDI BLACKBOLT  
pagina 241



Feliator manual RETRO 300  
pagina 236



Fierbator paste  
si galuste, de banc  
pagina 295



Suport pentru  
pagina 237



Gratare  
Kitchen Line  
pagina 303



Masina de ambalare  
vacuum Samic  
cu port pentru imprimanta  
si Bluetooth  
pagina 268

**NOU**



Incalzitor single  
pentru farfurii  
pagina 287



Lampa  
cu incalzire  
flexibila  
pagina 279



Set: Bain-marie  
HENDI RANGER +  
3x GN 1/3 cu capac  
pagina 292

Salamandra  
GN 1/1  
pagina 318



Sistem de gatit sous-vide  
prin circularea apei  
HENDI MASTERVIDE  
pagina 312



Prajitor cu 4 felii  
pagina 320



## Selectie articole noi 2024

Cuptor cu preparare accelerata  
HENDI SPEEDOVEN X90  
pagina 332



Cuptor cu  
convectie  
Millennium  
Smart Gastro  
pagina 350



Cutie pentru aluat  
de pizza GN1/1  
pagina 388



Tavi din aluminiu GN1/1  
cu invelis antiaderent  
CONVECTOMAT  
pagina 371

Dispozitiv de  
taiere pizza  
heavy-duty  
HENDI Pizzer  
pagina 400



Paleta pentru pizza  
pagina 396

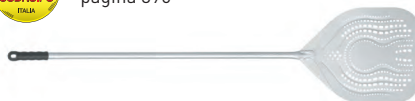

Lopata pentru cenusa  
pagina 393



Farfurie pentru  
pizza colectia  
Recipe Brick Red  
pagina 402



Presa pentru galuste  
pagina 418

**arktic**  
PROFESSIONAL REFRIGERATION



Dry aging cabinets  
pagina 435

**NOU**

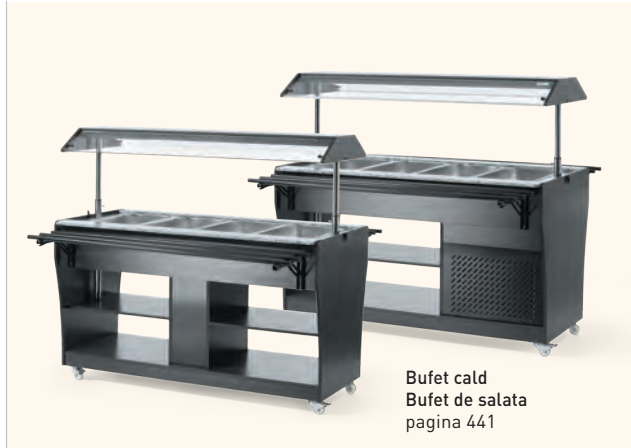

Bufet cold  
Bufet de salata  
pagina 441



Platou de servire  
din lemn de maslin  
pagina 460



Bol decorativ din  
lemn de masline  
pagina 462



Covorasa anti-aderent,  
model frunza – set  
pagina 467



Cos prezentare  
paine  
pagina 483



Platou cu margine  
inalta Oslo  
pagina 464



Latiera  
cu masura  
pagina 492



Scrumiera de sticla  
cu palnie de otel  
pagina 509



# Selectie articole noi 2024



## UNIQU

Buffet reinvented

pagina 510



BARUP  
BARWARE

Lama bar  
pagina 558



BARUP  
BARWARE

Tirbuson francez  
pagina 559



BARUP  
BARWARE

Economizor  
de vinuri cu vid  
pagina 580



BARUP  
BARWARE

Suport pentru  
pahare  
pagina 580



Filtru Hawthorne  
pagina 566



BARUP  
BARWARE

Barkit  
in tube  
pagina 573

Blender  
digital  
pentru bar  
pagina 585



Storicator  
de citrice  
pagina 583





Storicator de  
citrice electric  
pagina 587



Filtre HENDI  
pentru apa  
pagina 676



Aparat pentru  
cuburi de  
gheata  
pagina 595



**arktic**  
Aparat de  
facut gheata  
glazurata  
pagina 591



Dozator  
de apa  
pagina 612

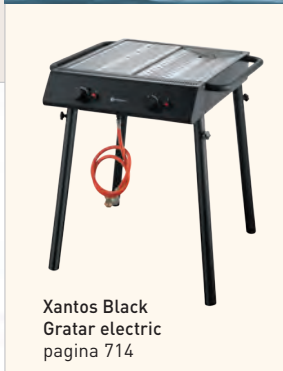

Xantos Black  
Gratar electric  
pagina 714



Friptura-Master  
Pro Negru  
pagina 709





Manere care nu se incalzesc

Orificii evacuare abur



## SERIA PROFI LINE

- Manere solide care nu se incalzesc, cu multiple puncte de fixare pe suprafata vasului.
- Rezistent la acizi.
- Partea inferioara tip sandwich [otel inoxidabil/aluminiu/ otel inoxidabil] combina conductivitatea termica a aluminiului cu rezistenta si proprietatile magnetice ale otelului inoxidabil pentru a permite gătirea pe inducție.
- Partea inferioara este formata prin lipire cu impact sudand fara probleme partile componente - acest proces garanteaza rezistenta la coroziune si distributia optima a caldurii.

831403

831007



Vezi filmul

Baza tip „sandwich”, formata prin lipire cu impact

### OALA INALTA - CU CAPAC

cod	litri	perete (mm)	mm	lei
832004	3	0.7	ø160x(H)150	134,99
832202	6	0.7	ø200x(H)190	174,99
832400	10	0.7	ø240x(H)220	199,90
832509	16	0.7	ø280x(H)260	299,99
832608	24	0.8	ø320x(H)300	389,99
832707	37	1	ø360x(H)360	699,99
832806	50	1	ø400x(H)400	809,99
832929	70	1	ø450x(H)450	1099,00

830055

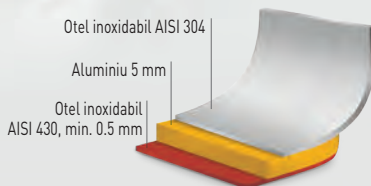

### OALA MEDIE - CU CAPAC

cod	litri	perete (mm)	mm	lei
831007	2	0.7	ø160x(H)110	119,99
831205	4	0.7	ø200x(H)130	144,99
831403	7	0.7	ø240x(H)150	219,99
831502	10	0.7	ø280x(H)170	259,99
831601	15	0.8	ø320x(H)190	359,99
831700	23.5	1	ø360x(H)230	529,99

### OALA JOASA - CU CAPAC

cod	litri	perete (mm)	mm	lei
830000	1.5	0.7	ø160x(H)75	104,99
830208	2.8	0.7	ø200x(H)90	127,99
830406	4.8	0.7	ø240x(H)105	184,99
830505	7.5	0.7	ø280x(H)120	219,99
830604	12	0.8	ø320x(H)150	334,99

## BAZA TIP SANDWICH DIN STRATURI MULTIPLE

vas rece



vas cald

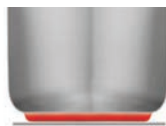

- integrare perfecta - baza este formata prin lipire prin impact, care asigura imbinarea perfecta a straturilor
- rezistenta la coroziune
- pana la 30% energie economisita prin distributie mai rapida a caldurii - gatire mai rapida
- distributie optima a caldurii pe toata suprafata inferoara
- baza tip sandwich formata prin lipire prin impact sub o greutate de 2.500 de tone
- puritatea aluminiului - 95%
- peste 99% eficienta de lipire a 3 straturi

### CRATITA SOS - FARA CAPAC

- Maner lung din otel inoxidabil

cod	litri	perete (mm)	mm	lei
830048	1	0.7	ø140x(H)70	<b>59,99</b>
830055	1.5	0.7	ø160x(H)75	<b>61,99</b>
830154	2	0.7	ø180x(H)80	<b>89,99</b>
830253	3	0.7	ø200x(H)90	<b>99,99</b>



830048

### CRATITA SOTE - FARA CAPAC

- Maner lung din otel inoxidabil

cod	litri	perete (mm)	mm	lei
830352	0.9	0.7	ø160x(H)60	<b>56,99</b>
830376	1.5	0.7	ø200x(H)60	<b>84,99</b>



830352

### TIGAIIE PRAJIT - FARA CAPAC

- Maner lung din otel inoxidabil

cod	perete (mm)	mm	lei
835432	0.7	ø240x(H)45	<b>94,49</b>
835531	0.7	ø280x(H)50	<b>117,99</b>
835630	0.7	ø320x(H)55	<b>144,99</b>



835432

### TIGAIIE PRAJIT CU STRAT ANTI-ADERENT - FARA CAPAC

- Strat anti-aderent Teflon® Platinum Plus

- Maner lung din otel inoxidabil

- Maner fixat cu nituri

cod	perete (mm)	mm	lei
835500	0.7	ø280x(H)50	<b>194,99</b>
835401	0.7	ø240x(H)45	<b>159,99</b>
835609	0.7	ø320x(H)55	<b>239,99</b>



835401

### ADAPTOR SUPORT VAS

- Pentru asezarea vaselor mici pe suporturile pentru vase mari

cod	mm	lei
839997	255x255x(H)25	<b>24,99</b>



839997



## SERIA KITCHEN LINE

- Otel inoxidabil, cu baza de tip „sandwich”
- Combina conductivitatea termica a aluminiului cu rezistenta si proprietatile magnetice ale otelului pentru a permite gatirea pe inductie
- Finisaj satinat la toate suprafetele exterioare
- Manere din otel cu fixare multipla, nu se incalzesc

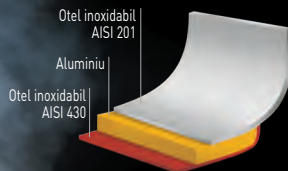



837306

### OALA INALTA - CU CAPAC

cod	litri	perete (mm)	mm	lei
837108	2.8	0.6	ø160x(H)140	<b>99,99</b>
837207	5	0.6	ø200x(H)160	<b>149,99</b>
837306	9	0.7	ø240x(H)200	<b>184,99</b>
837405	13.5	0.7	ø280x(H)220	<b>259,99</b>
837603	21	0.8	ø320x(H)270	<b>424,99</b>



836309

### OALA MEDIE - CU CAPAC

cod	litri	perete (mm)	mm	lei
836101	1.9	0.6	ø160x(H)95	<b>95,69</b>
836200	3.5	0.6	ø200x(H)115	<b>119,99</b>
836309	6	0.6	ø240x(H)135	<b>139,99</b>
836408	9.5	0.7	ø280x(H)155	<b>194,99</b>
836507	15	0.8	ø320x(H)190	<b>249,99</b>



836026

### OALA JOASA - CU CAPAC

cod	litri	perete (mm)	mm	lei
836002	1.5	0.6	ø160x(H)75	<b>89,99</b>
836019	2.9	0.6	ø200x(H)95	<b>94,99</b>
836026	4.9	0.6	ø240x(H)110	<b>139,99</b>
836033	7.3	0.7	ø280x(H)120	<b>169,99</b>
836040	12	0.8	ø320x(H)150	<b>219,99</b>



838105



Vezi filmul

### CRATITA - FARA CAPAC

- Maner lung din otel inoxidabil

cod	litri	perete (mm)	mm	lei
838105	1.5	0.6	ø160x(H)75	<b>54,99</b>
838204	2.9	0.6	ø200x(H)95	<b>74,99</b>
838303	4.9	0.6	ø240x(H)110	<b>94,99</b>



839409

### CRATITA SOTE - FARA CAPAC

- Maner lung din otel inoxidabil

cod	litri	perete (mm)	mm	lei
839300	1	0.6	ø160x(H)60	<b>59,99</b>
839409	1.7	0.6	ø200x(H)65	<b>74,99</b>



838501

### TIGAIE PRAJIT - FARA CAPAC

- Maner lung din otel inoxidabil

cod	perete (mm)	mm	lei
838501	0.6	ø240x(H)50	<b>74,99</b>
838600	0.6	ø280x(H)50	<b>94,99</b>
838617	0.7	ø320x(H)50	<b>134,99</b>





## SERIA BUDGET LINE

- Baza de tip sandwich (otel inoxidabil/aluminiu/otel inoxidabil 18/0) combina conductivitatea termica a aluminiului cu rezistenta si proprietatile magnetice ale aluminului inoxidabil, pentru a permite gatirea prin inductie
- Finisaj satinat pe suprafetele exterioare
- Manere care nu se incalzesc, fixate cu nituri
- Capac cu orificii evacuare aburi



Otel inoxidabil  
AISI 201

Aluminiu 3-4 mm

Otel inoxidabil  
AISI 430

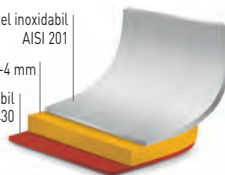

Vezi filmul



## OALA CU CAPAC

cod	litri	perete (mm)	mm	lei
832882	17	0.8	ø280x(H)280	<b>204,99</b>
832899	21	0.8	ø300x(H)300	<b>279,99</b>
834206	25	0.8	ø345x(H)350	<b>299,99</b>
834404	36	1	ø360x(H)360	<b>379,99</b>
834701	50	1	ø400x(H)400	<b>459,99</b>
834909	71	1	ø450x(H)450	<b>549,99</b>
835104	98	1	ø500x(H)500	<b>649,99</b>

## OALA MEDIE - CU CAPAC

cod	litri	perete (mm)	mm	lei
832820	9	0.8	ø250x(H)180	<b>165,99</b>
832837	14	0.8	ø300x(H)200	<b>204,99</b>
832844	23	1	ø350x(H)240	<b>269,99</b>
832851	32	1	ø400x(H)260	<b>389,99</b>

Baza tip sandwich



Manere fixate cu nituri



Manerele nu se incalzesc





833032

### CRATITA BAIN-MARIE

- Pereti dubli, cu rezervor pentru apa.
- Umpleti rezervorul cu apa pentru a topi ciocolata la bain-marie.
- Cu manere din otel inoxidabil.

cod	litri	mm	lei
833032	1	330x165x(H)95	<b>79,99</b>



Vezi filmul

18/0  
stainless steel



833506



Vezi filmul

18/10  
stainless steel

Cu carlig suplimentar pentru sprijin in timpul golirii

### COS FIERBERE PASTE

- Potrivit pentru oale Ø 360 mm - cod produs 831700
- Cu carlig suplimentar pentru sprijin in timpul scurgerii

cod	litri	mm	lei
833506	1.5	160x160x(H)230	<b>199,99</b>



833100

### SET GATIRE LA ABUR PENTRU SPARANGHEL SI PASTE, XL

- Va permite sa gatiti sparanghel foarte lung
- Perfect pentru aburirea legumelor, pestelui, a pastelor, pentru pastrarea hot dog-urilor etc.
- Inclus: oala, insertie pentru aburi si capac

cod	litri	mm	lei
833100	5.5	ø162x(H)280	<b>159,99</b>



### TAVA COACERE

- Cu manere
- A nu se utiliza in contact direct cu sursa de incalzire

cod	mm	lei
508503	310x240x(H)50	<b>74,99</b>
508510	385x275x(H)60	<b>79,99</b>
508527	430x310x(H)60	<b>89,99</b>



508527

S.S.  
stainless steel





## TIGAI TURNATE DIN ALUMINIU ,TITANIUM PROFESSIONAL'

- Tigaie profesionala fabricata din aluminiu dur, potrivita pentru toate sursele de incalzire, chiar si pentru folosire in cuptor (pana la 250°C)
- Aluminiul turnat exceleaza la transmiterea caldurii, tigaia este gata de folosire in scurt timp
- Maner din otel inoxidabil 18/10 care nu se incalzeste in timpul folosirii
- Stratul anti-aderent 'Teflon™ Platinum Plus' are o rezistenta mare la temperatura (pana la 250°C), acoperirea este aplicata in 3 straturi fapt ce maresete rezistenta la uzura si face tigaia ideala pentru uz intensiv
- Foarte usor de curatat dupa utilizare



Vezi filmul



Strat grund: pentru rezistenta la coroziune, anti-soc si durabilitate mai buna a straturilor

Strat Titanium: anti-zgarieturi si anti-abraziune

Strat interior: Whitford® Xylan non-stick

Strat exterior: armarea stratului non-stick si lustruirea suprafetei

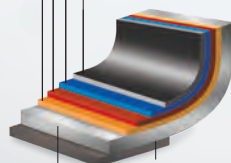

Baza din aluminiu

Baza inductie

## TIGAIE INDUCTIE PENTRU PRAJIT

cod	fund (mm)	mm	lei
629154	ø190	ø250x(H)50	168,99
629253	ø220	ø290x(H)55	214,99
629345	ø260	ø330x(H)60	229,99



## GRATAR CU INDUCTIE

- Poate fi folosit pe masinile de gatit cu inductie
- Fabricat din aluminiu turnat sub presiune cu un strat de teflon antiaderent
- Potrivit pentru surse de caldura de pana la 250°C

cod	mm	lei
629130	390x260x(H)35	109,99



## TIGAI TURNATE DIN ALUMINIU ,TITANIUM PROFESSIONAL'

- Tigai profesionala fabricata din aluminiu dur, potrivita pentru toate sursele de incalzire, exceptand inductia, chiar si pentru folosire in cuptor (pana la 250°C)
- Aluminiul turnat exceleaza la transmiterea caldurii, tigaia este gata de folosire in scurt timp
- Maner din otel inoxidabil 18/10 care nu se incalzeste in timpul folosirii
- Stratul non-stick Whitford® Xylan are rezistenta la temperaturi ridicate (pana la 250°C), lipirea stratului anti-aderent este imbunatatita printr-un strat de titan intre aluminiu si stratul anti-aderent, aceasta procedura cu doua straturi imbunatateste durata de viata a stratului anti-aderent si asigura o rezistenta suplimentara la zgarieturi
- Foarte usor de curatat dupa utilizare



Strat grund: anti-corozivune, anti-soc care ofera o durabilitate mai mare straturilor

Strat Titanium: pentru anti-zgarieturi si anti-abraziune

Strat interior: Whitford® Xylan non-stick

Strat exterior: armarea stratului non-stick si lustruirea suprafetei

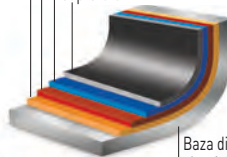

Baza din aluminiu



629208

## TIGAIE PRAJIT TITANIUM PROFESSIONAL

cod	fund (mm)	mm	lei
629109	ø180	ø240x(H)55	144,99
629307	ø260	ø320x(H)55	179,99
629208	ø220	ø280x(H)55	189,99
629352	ø300	ø360x(H)55	239,99
629390	ø340	ø400x(H)55	269,99



839010



Vezi filmul



629505

## WOK TITANIUM PROFESSIONAL

cod	fund (mm)	mm	lei
839010	ø157	ø320x(H)100	189,99

## TIGAIE SOTE TITANIUM PROFESSIONAL

cod	fund (mm)	mm	lei
629505	ø225	ø280x(H)85	179,99



Vezi filmul



629802



Vezi filmul



629604



Vezi filmul



629413

## TIGAI GRILL - SUPRAFATA STRIATA TITANIUM PROFESSIONAL

cod	fund (mm)	mm	lei
629802	ø220	550x290x(H)55	169,99

## TIGAI PRAJIT PESTE - OVALA TITANIUM PROFESSIONAL

cod	fund (mm)	mm	lei
629604	ø175	400x275x(H)35	199,99

## TIGAI CLATITE TITANIUM PROFESSIONAL

cod	fund (mm)	mm	lei
629413	ø260	ø320x(H)20	174,99

Pret catalog fara TVA

HENDI

27



## TIGAI ALUMINIU ,MARBLE PROFESSIONAL'

- Tigaie profesionala fabricata din aluminiu dur, potrivita pentru toate sursele de incalzire, chiar si pentru folosire in cuptor
- Aluminiul ofera transmisie optima a caldurii, tigaia este gata de folosire in scurt timp
- Manerul este din otel acoperit epoxidic
- Stratul 'Marble' anti-aderent are o rezistenta mare la temperatura (pana la 260°C), acoperirea este in 3 straturi si este foarte rezistenta la uzura
- Foarte usor de curatat dupa utilizare



Stratul interior imbunatateste proprietatile adezive ale celorlalte straturi

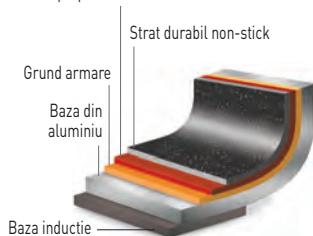

Vezi filmul



627631



### TIGAIE PENTRU PRAJIT

cod	fund (mm)	mm	lei
627600	ø140	ø200x(H)40	<b>69,99</b>
627617	ø180	ø240x(H)42	<b>74,99</b>
627662	ø200	ø260x(H)45	<b>109,99</b>
627624	ø220	ø280x(H)50	<b>119,99</b>
627631	ø260	ø320x(H)50	<b>129,99</b>
627648	ø280	ø360x(H)50	<b>159,99</b>
627655	ø300	ø390x(H)50	<b>199,99</b>



627747



627686



627716

### TIGAIE WOK

cod	fund (mm)	mm	lei
627730	ø210	ø280x(H)75	<b>134,99</b>
627747	ø210	ø320x(H)95	<b>159,99</b>

### TIGAIE CLATITE

cod	fund (mm)	mm	lei
627679	ø240	ø280x(H)25	<b>79,99</b>
627686	ø280	ø320x(H)20	<b>109,99</b>

### TIGAI PENTRU PRAJIT PESTE - OVALA

cod	fund (mm)	mm	lei
627716	ø185	280x400x(H)55	<b>189,99</b>

## TIGAI ALUMINIU ,PLATINUM PROFESSIONAL'

- Fabricate din aluminiu rezistent, potrivite pentru toate sursele de incalzire
- Aluminiul exceleaza la transmiterea caldurii, tigaia este gata de folosire in scurt timp
- Maner din otel inoxidabil izolat cu silicon, pentru o buna aderenta
- Stratul anti-aderent 'Teflon™ Platinum Plus' are o rezistenta mare la temperatura (pana la 260°C), acoperirea este aplicata in 3 straturi fapt ce maresc rezistenta la uzura si face tigaia ideala pentru uz intensiv
- Foarte usor de curatat dupa utilizare



Stratul interior imbunatateste proprietatile adezive ale celorlalte straturi

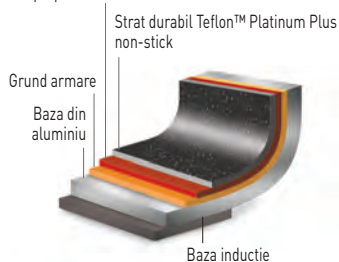

Vezi filmul

Maner izolat



### TIGAI PENTRU PRAJIT

cod	fund (mm)	mm	lei
621103	ø140	ø200x(H)44	119,99
621110	ø180	ø240x(H)50	145,99
621127	ø200	ø260x(H)52	159,99
621134	ø200	ø280x(H)52	174,99
621158	ø215	ø320x(H)60	204,99

Grill gaz Fiesta la pagina XX



### TIGAI PAELLA

- Tigaie din tabla de otel de inalta calitate
- Cu doua manere

cod	Potrivita pentru grill gaz	mm	lei
622100		ø340x(H)40	49,99
622308		ø460x(H)40	88,99
622407	Fiesta 146002	ø600x(H)40	174,99
622605	Fiesta 146804	ø800x(H)50	394,99





## TIGAI DIN OTEL CLASIC

- Traditionalele tigai pentru prajit fabricate din otel laminat.
- Tigai preferate de bucatarii profesionisti.
- Simplitate, calitate, fermitate si versatilitate, caracteristici apreciate de multe generatii.



Vezi filmul



628614

### TIGAIE PENTRU PRAJIT

cod	baza (mm)	mm	lei
628638	ø180	ø240x(H)45	<b>79,99</b>
628614	ø220	ø280x(H)50	<b>109,99</b>
628706	ø240	ø300x(H)50	<b>119,99</b>
628621	ø260	ø320x(H)50	<b>129,99</b>



628805

### TIGAI CLATITE

cod	baza (mm)	mm	lei
628805	ø200	ø230x(H)25	<b>69,99</b>

## INAINTE DE PRIMA UTILIZARE



**Pasul 1**  
Puneti ulei in tigaie si incingeti. Adaugati coji de cartofi si ulita sare, apoi lasati la prajit pentru putin timp.



**Pasul 2**  
Luati un prosop de bucatarie si frecati incet tigaia pe interior, cu amestecul obtinut



**Pasul 3**  
Goliti tigaia dupa ce ati frecat pe interior. Vor ramane reziduurile de la cojile de cartofi.



**Pasul 4**  
Pentru a indeparta reziduurile adaugati o cantitate mare de sare si frecati tigaia pe interior cu ajutorul unui prosop de bucatarie. Nu executati aceste proceduri cand tigaia este pe foc.



**Pasul 5**  
Indepartati sarea, stergeti tigaia si turnati un strat subtire de ulei.



**Pasul 6**  
Intindeti uleiul pe interiorul tigiailor cu un prosop curat de bucatarie. Acum tigaia este pregatita pentru folosire sau depozitare.



### OALA DIN FONTA EMAILATA

- Fabricata in intregime din fonta, acoperita cu un strat de email.
- Capac cu denivelari in interior care directioneaza condensul spre marginile capacului, pastrand umiditatea preparatului si aroma acestuia.
- Adecvat pentru toate sursele de caldura, inclusiv inductie.
- Nu poate fi spalat in masina de spalat vase.
- Disponibila in diferite dimensiuni; cea mai mica poate fi utilizata ca vas pentru garnitura pentru servire (cod: 626856).

cod	litri	mm	lei
626856	0.27	130x100x(H)48	129,99
626832	3.7	317x240x(H)105	219,99
626849	4.4	365x290x(H)115	249,99
626825	6.88	405x255x(H)134	308,99





**NOU**



food contact



oven



wood

### OALA DIN FONTA

- Set complet cu capac si maner.
- Manerul este ideal pentru deplasarea și manevrarea vasului deasupra focului.
- Pe 3 picioare - design traditional descendent din Africa de Sud.
- Capacitate: 6 l.

cod	mm	lei
629291	ø245x(H)280	279,99



**NOU**

629376

**OTALA DIN FONTA**

- Set complet cu capac si maner.
- Manerul este ideal pentru manevrare si pentru suspendarea deasupra flacarii.
- Capacitate: 9 L.

cod	mm	lei
629376	ø310x(H)155	291,99

**NOU**

629369

**TIGAIIE GRILL DIN FONTA**

- Suprafata cu striatii pentru frigerea la gratar.
- Cu o scurgere pentru eliminarea usoara a excesului de ulei/ grasimi.
- Maner cu un orificiu pentru suspendare.

cod	mm	lei
629369	265x265x(H)50	104,99



629932

**TIGAIIE DIN FONTA TIP GRATAR**

- Maner din fonta.

cod	mm	lei
629932	230x230x(H)25	226,99



629925

**TIGAIIE PRAJIT PESTE - OVALA TITANIUM PROFESSIONAL**

- Maner din fonta.

cod	mm	lei
629925	510x274x(H)27	363,99



629949

**TIGAIIE UNIVERSALA DIN FONTA**

cod	mm	lei
629949	ø260x(H)44	226,99

**NOU**

629338

**TIGAIIE DIN FONTA**

- Cu 2 fante de scurgere - cate 1 pe fiecare parte.
- Maner mare cu orificiu pentru suspendare.
- Disponibil in 3 marimi (629314, 629321, 629338).

cod	mm	lei
629314	ø165	57,99
629321	ø200x(H)40	69,99
629338	ø250x(H)40	80,99

**NOU**

629383

**PLATOU DIN FONTA CU BAZA DIN LEMN SI CLESTE**

- Manerul placii si clestului este fabricat din fonta.
- Baza din lemn de mesteacan.
- Platau sigur pentru cuptor.
- Setul nu poate fi spalat in masina de spalat vase.

cod	mm	lei
629383	280x140x(H)30	69,99



## SERIE TIGAI CURPU

- Grosimea de 2,5 mm cu 3 straturi din oțel inoxidabil (0,4 mm), aluminiu (1,5 mm) și cupru (0,4 mm).
- Manerele sunt nituite.



## TIGAIE PENTRU PRAJIT

cod	grosime (mm)	mm	lei
607060	2.5	ø240x(H)150	239,99

607060

## DALE PENTRU SCOICI SI SOSURI



## DALE PENTRU SCOICI - CU CAPAC

- Emailata, de culoare neagra
- Margine din oțel inoxidabil

625057

cod	max. continut in kg.	litri	mm	lei
625606	0.5	0.8	ø140x(H)150	49,99
625002	1	2.5	ø200x(H)190	68,99
625057	1.5	3.5	ø220x(H)200	74,99
625101	2	5	ø260x(H)210	90,99



625804



625705

## OALA SUPA & SOS - CU CAPAC

- Emailata
- Margine din oțel inoxidabil
- Capac scund

cod	-	litri	mm	lei
625804	Albastra	0.5	ø115x(H)95	49,99
625705	Neagra	0.65	ø135x(H)110	44,99



839003

Otel inoxidabil 18/8 (0,4 mm)  
Aluminiu (1,5 mm)  
Otel inoxidabil 18/0 (0,5 mm)



### WOK 3 STRATURI - FARA CAPAC

- Construcie de 3 straturi: aluminiu (1,5 mm), un strat exterior de otel inoxidabil 18/0 (0,5 mm) si un strat interior din otel inoxidabil 18/8 (0,4 mm)
- Incalzire rapida si distributie de caldura excelenta
- Foarte durabil prin rezistenta la uzura
- Maner lung din otel inoxidabil
- Cu baza plata Ø 145 mm

cod	mm	lei
839003	ø360x(H)90	229,99



622742

### TIGAIE EMAILATA PAELLA

- Cu 2 manere
- Strat din otel emailat

cod	mm	lei
622704	ø100x(H)20	29,99
622711	ø120x(H)25	32,99
622728	ø150x(H)27	33,99
622735	ø200x(H)36	40,99
622742	ø240x(H)40	44,99



622858

### BOL EMAILAT PENTRU PAELLA

- Model adanc
- Strat din otel emailat

cod	mm	lei
622810	ø145x(H)40	34,99
622827	ø170x(H)40	39,99
622834	ø185x(H)43	42,99
622841	ø205x(H)57	49,99
622858	ø245x(H)70	54,99





## TAVI GASTRONORM



TAVI GASTRONORM  
PROFI LINE



TAVI GASTRONORM  
KITCHEN LINE



TAVI GASTRONORM  
BUDGET LINE



TAVI GASTRONORM  
DIN POLICARBONAT  
TRANSPARENT

### POTRIVITE PENTRU:

Cuptoare convectie	✓	✓	✓	
Sisteme bain-marie	✓	✓	✓	
Chafing dish-uri	✓	✓	✓	
Refrigeratoare	✓	✓	✓	✓
Depozitare alimente	✓	✓	✓	✓
Spalare la masina de spalat vase	✓	✓	✓	✓

### PROPRIETATI:

Pentru folosire la temperaturi	-40°C / 300°C	-40°C / 300°C	-40°C / 300°C	-40°C / 110°C
Stocabile	✓	✓	✓	✓

### CONSTRUCTIE:

Fabricate din	otel inoxidabil 18/10	otel inoxidabil	otel inoxidabil	policarbonat
Grosime (mm)	0,6-0,8	0,6-0,7	0,6-0,7	2-3
Inaltimi disponibile (mm)	20 pana la 200	20 pana la 200	20 pana la 200	65 pana la 200

### ACCESORII:

Tavi perforate	✓	✓		
Capace	✓	✓	✓	✓
Capace cu garnitura din silicon	✓	✓	✓	
Capace cu fanta pentru lingura	✓	✓		
Tava picurare		✓		✓
Adaptor imbinare tavi	✓	✓	✓	

### INFORMATII ADITIONALE:

Usor de curatat	✓	✓	✓	✓
Dimensiune GN gravata		✓		✓
Scala de capacitate				✓
Nu absoarbe mirosuri sau arome	✓	✓	✓	✓
	<p>Conforme cu cele mai stricte reglementari pentru contactul cu alimentele (pentru spitale)</p> <ul style="list-style-type: none"> <li>• Rezistenta excelenta la coroziune (rezistenta la salinitate si aciditate)</li> <li>• Raza redusa pentru a se asigura continut maxim</li> <li>• Foarte solide si durabile</li> <li>• Usor de curatat</li> </ul>	<p>Colturi intarite pentru a mari rezistenta</p> <ul style="list-style-type: none"> <li>• Marimea GN gravata</li> <li>• Rezistenta la coroziune daca se foloseste corect</li> <li>• Usor de curatat</li> </ul>	<p>Rezistenta la coroziune daca se foloseste corect</p> <ul style="list-style-type: none"> <li>• Usor de curatat</li> </ul>	<p>Rezistenta mare la impact, foarte durabile</p> <ul style="list-style-type: none"> <li>• Nu absoarb mirosuri sau arome</li> <li>• Marimea GN gravata in partea de jos</li> <li>• Cu scala capacitate</li> <li>• Material transparent</li> <li>• Usor de curatat</li> </ul>



**TAVI GASTRONORM  
DIN POLICARBONAT  
NEGRU & ALB**



**TAVI GASTRONORM  
DIN POLIPROPILENA**



**CONTAINERE  
HACCP DEPOZITARE**



**TAVI GASTRONORM  
DIN PORTELAN**

			✓
✓	✓	✓	✓
✓	✓	✓	✓
✓	✓	✓	✓
-40°C / 110°C	-40°C / 80°C	-40°C / 80°C	under 600°C
✓	✓	✓	✓
poli carbonat	polipropilena	polipropilena	portelan
2-3	2-2,9	2-2,9	
65 pana la 150	100 pana la 200	65 pana la 200	20 pana la 65
✓	✓	✓	
	✓		
✓			✓
✓	✓	✓	✓
✓	✓	✓	✓
<ul style="list-style-type: none"> <li>• Perfecte pentru prezentare</li> <li>• Rezistenta mare la impact, foarte durabile</li> <li>• Nu absorb mirosuri sau arome</li> <li>• Marimea GN gravata in partea de jos</li> <li>• Cu scala capacitate</li> <li>• Material foarte transparent</li> <li>• Usor de curatat</li> </ul>	<ul style="list-style-type: none"> <li>• Marimea GN gravata</li> <li>• Cu scala capacitate</li> <li>• Material transparent</li> <li>• Nu absorb mirosuri sau arome</li> </ul>	<ul style="list-style-type: none"> <li>• Eticheta HACCP de monitorizare a procesului de depozitare alimentare</li> <li>• Marimea GN gravata</li> <li>• Cu scala capacitate</li> <li>• Material transparent</li> <li>• Nu absorb mirosuri sau arome</li> <li>• Clipsuri colorate pentru capace, conforme HACCP, se vand separat</li> </ul>	<ul style="list-style-type: none"> <li>• Portelan special, cel mai rezistent tip disponibil</li> <li>• Rezistenta la socuri termice, la schimbari extreme de temperatura</li> <li>• Rezistenta la uzura si la impact, desi este relativ usor</li> <li>• Alb extrem de pur si stralucitor</li> </ul>





## GHID DIMENSIUNI GN

- Dimensiuni standard utilizate in industria alimentara, determinata in standardul PN-EN 631-1:1996.
- Standardizarea dimensiunilor faciliteaza utilizarea acestora in diverse aparate de bucatarie care sunt proiectate pe baza acestor dimensiuni, de ex. in cuptoare, cutii termoizolante pentru transport, dulapuri frigorifice, bain-marie, carucioare de transport



inaltime (mm)



### DIMENSIUNILE RECIPIENTELOR GN:

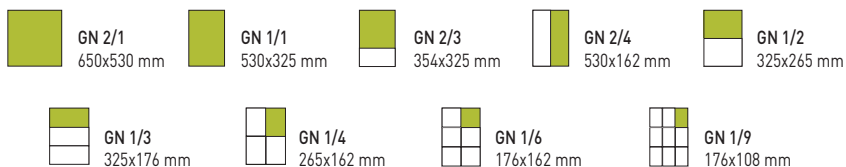

## TAVI GASTRONORM

- Fabricate din oțel inoxidabil 18/10 de înaltă calitate
- Design foarte solid
- Margini netede, ușor de curățat
- Pot fi utilizate în cuptoare convecție, frigider, sisteme bain-marie și chafing dish-uri

# MORI2A



Foarte rezistent și durabil

Pentru utilizare la temperaturi de -40 °C/300°C

Rezistență excelentă la coroziune

Raza interioară redusă mărește capacitatea maximă



GN 2/1 GN 1/1 GN 2/3 GN 1/2 GN 1/3 GN 1/4 GN 1/6 GN 1/9

650x530 mm 530x325 mm 354x325 mm 325x265 mm 325x176 mm 265x162 mm 176x162 mm 176x108 mm

2/1



801109

1/1



801222

2/3



801307

cod	litri	grosime (mm)	inaltime (mm)	lei
801109	58	0.8	200	<b>424,99</b>
801116	43	0.8	150	<b>322,99</b>
801123	30	0.8	100	<b>259,99</b>
801130	19	0.8	65	<b>224,99</b>
801147	11	0.8	40	<b>189,99</b>
801154	5.5	0.8	20	<b>179,99</b>

cod	litri	grosime (mm)	inaltime (mm)	lei
801208	28	0.8	200	<b>229,99</b>
801215	21	0.8	150	<b>194,99</b>
801222	14	0.8	100	<b>129,99</b>
801239	9	0.8	65	<b>114,99</b>
801246	5	0.8	40	<b>99,99</b>
801253	2.5	0.8	20	<b>89,99</b>

cod	litri	grosime (mm)	inaltime (mm)	lei
801307	18	0.8	200	<b>189,99</b>
801314	13	0.8	150	<b>164,99</b>
801321	9	0.7	100	<b>104,99</b>
801338	5.5	0.7	65	<b>84,99</b>
801345	3	0.7	40	<b>79,99</b>
801352	1.5	0.7	20	<b>59,99</b>

2/4



801840

1/2



801406

1/3



801512

cod	litri	grosime (mm)	inaltime (mm)	lei
801840	8.6	0.7	150	<b>169,99</b>
801666	5.8	0.7	100	<b>134,99</b>
801857	4	0.7	65	<b>99,99</b>
801864	2.5	0.7	40	<b>79,99</b>
801871	1.2	0.7	20	<b>59,99</b>

cod	litri	grosime (mm)	inaltime (mm)	lei
801406	12.5	0.8	200	<b>133,99</b>
801413	9.5	0.7	150	<b>124,99</b>
801420	6.5	0.7	100	<b>84,99</b>
801437	4	0.7	65	<b>69,99</b>
801444	2	0.7	40	<b>60,99</b>
801451	1	0.7	20	<b>47,99</b>

cod	litri	grosime (mm)	inaltime (mm)	lei
801505	7.8	0.8	200	<b>134,99</b>
801512	5.7	0.7	150	<b>91,99</b>
801529	4	0.7	100	<b>69,99</b>
801536	2.5	0.7	65	<b>59,99</b>
801543	1.5	0.7	40	<b>54,99</b>
801550	0.8	0.7	20	<b>44,99</b>



1/4



801635

cod	litri	grosime (mm)	inaltime (mm)	lei
801604	5.5	0.8	200	<b>109,99</b>
801611	4	0.7	150	<b>89,99</b>
801628	2.8	0.7	100	<b>64,99</b>
801635	1.8	0.7	65	<b>54,99</b>
801642	1.7	0.7	40	<b>49,99</b>
801659	0.9	0.7	20	<b>44,99</b>

1/6



801727

cod	litri	grosime (mm)	inaltime (mm)	lei
801703	3.4	1	200	<b>114,99</b>
801710	2.4	0.8	150	<b>79,99</b>
801727	1.6	0.7	100	<b>50,99</b>
801734	1	0.7	65	<b>41,99</b>

1/9



801826

cod	litri	grosime (mm)	inaltime (mm)	lei
801826	1	0.7	100	<b>59,99</b>
801833	0.6	0.7	65	<b>42,99</b>

## TAVA PERFORATA GASTRONORM

- Partea inferioara perforata.
- Laturi perforate cu o inaltime de 100 mm sau mai mare.

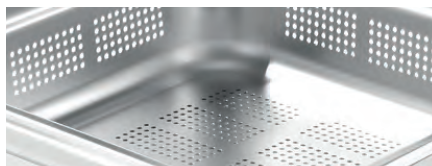

1/1



802236

cod	litri	grosime (mm)	inaltime (mm)	lei
802205	28	0.8	200	<b>255,99</b>
802212	21	0.8	150	<b>234,99</b>
802229	14	0.8	100	<b>149,99</b>

- Baza perforata

cod	litri	grosime (mm)	inaltime (mm)	lei
802236	9	0.8	65	<b>119,99</b>
802243	5	0.8	40	<b>97,99</b>
802168	2.5	0.8	20	<b>88,99</b>

2/3



802328

cod	litri	grosime (mm)	inaltime (mm)	lei
802328	9	0.7	100	<b>124,99</b>

- Baza perforata

cod	litri	grosime (mm)	inaltime (mm)	lei
802335	5.5	0.7	65	<b>81,99</b>
802342	3	0.7	40	<b>80,79</b>

1/2



802427

cod	litri	grosime (mm)	inaltime (mm)	lei
802427	6.5	0.7	100	<b>87,99</b>

- Baza perforata

cod	litri	grosime (mm)	inaltime (mm)	lei
802434	4	0.7	65	<b>66,99</b>
802441	2	0.7	40	<b>60,99</b>

1/3



802526

cod	litri	grosime (mm)	inaltime (mm)	lei
802502	7.8	0.7	200	<b>149,99</b>
802519	5.7	0.7	150	<b>108,99</b>
802526	4	0.7	100	<b>73,99</b>

- Baza perforata

cod	litri	grosime (mm)	inaltime (mm)	lei
802533	2.5	0.7	65	<b>59,99</b>
802540	1.2	0.7	40	<b>49,99</b>

## GN CONTAINERE CU MANERE LATERALE

# MORI2A

1/1



803202

cod	litri	grosime (mm)	inaltime (mm)	lei
803202	28	0.8	200	244,99

2/3



803301

cod	litri	grosime (mm)	inaltime (mm)	lei
803301	18	0.8	200	239,99

1/2



803400

cod	litri	grosime (mm)	inaltime (mm)	lei
803400	12.5	0.8	200	169,99

1/3



803509

cod	litri	grosime (mm)	inaltime (mm)	lei
803509	7.8	0.8	200	179,99

1/4



803608

cod	litri	grosime (mm)	inaltime (mm)	lei
803608	5.5	0.8	200	159,99

1/6



803707

cod	litri	grosime (mm)	inaltime (mm)	lei
803707	3.4	0.8	200	129,99



804100

### CAPAC GASTRONORM FARA FANTA PENTRU LINGURA SERVIRE

- Se potriveste containerelor din poliparbonat

cod	grosime (mm)	GN	mm	lei
804100	0.8	GN 1/1	530x325	92,99
804117	0.7	GN 2/3	354x325	62,99
804179	0.8	GN 2/4	530x162	59,99
804124	0.7	GN 1/2	265x325	51,99
804131	0.7	GN 1/3	325x176	43,99
804148	0.7	GN 1/4	265x162	38,49
804155	0.7	GN 1/6	176x162	32,99
804162	0.7	GN 1/9	176x108	29,99



804209

### CAPAC GASTRONORM CU MANER

cod	GN	mm	lei
804209	GN 1/1	530x325	100,99
804216	GN 2/3	354x325	74,99
804223	GN 1/2	265x325	64,99
804230	GN 1/3	325x176	53,99
804247	GN 1/4	265x162	50,99
804254	GN 1/6	176x162	43,99

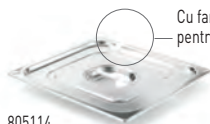

805114

### CAPAC GASTRONORM CU FANTA PENTRU LINGURA SERVIRE

- Se potriveste containerelor din poliparbonat

cod	grosime (mm)	GN	mm	lei
805138	0.7	GN 1/3	325x176	46,99
805107	0.7	GN 1/1	530x325	99,99
805114	0.7	GN 2/3	354x325	64,99
805121	0.7	GN 1/2	265x325	55,99
805145	0.7	GN 1/4	265x162	42,99
805152	0.7	GN 1/6	176x162	38,99



804322

### CAPAC GASTRONORM CU MANER SI MARGINE DE SILICON

cod	GN	mm	lei
804315	GN 2/3	354x325	179,99
804322	GN 1/2	265x325	169,99
804339	GN 1/3	325x176	135,99
804346	GN 1/4	265x162	109,99

Cu fanta pentru lingura



802601

### CAPAC GASTRONORM CU BANDA SILICONATA

- Cu banda siliconata pentru inchidere ermetica

- Potrivite doar pentru tavi din seria Profi Line si tavi din poliparbonat

- Inchiderea ermetica permite pastrarea alimentelor proaspete si impiedica scurgerea in timpul transportului

cod	GN	mm	lei
802601	GN 1/1	530x325	214,99
802618	GN 2/3	354x325	159,99
802625	GN 1/2	265x325	150,99
802632	GN 1/3	325x176	120,99
802649	GN 1/4	265x162	96,99
802656	GN 1/6	176x162	94,99





## TAVI GASTRONORM SERIA KITCHEN LINE

- Rezistenta sporita datorita culturilor intarite, marimea GN gravata
- Margini netede, usor de curatat
- Pot fi utilizate in cuptoare convectie, frigidera, sisteme bain-marie si chafing dish-uri

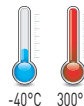

Foarte rezistent datorita culturilor ranforsate

Pentru utilizare la temperaturi de -40 °C/300°C

Rezistent la coroziune (cand este utilizat corect)

Grosime 0,6-0,7 mm

GN 1/1	GN 2/3	GN 1/2	GN 1/3	GN 1/4	GN 1/6	GN 1/9
530x325 mm	354x325 mm	325x265 mm	325x176 mm	265x162 mm	176x162 mm	176x108 mm



806142



806241



806340

cod	litri	grosime (mm)	inaltime (mm)	lei
806159	28	0.7	200	134,99
806142	21	0.7	150	129,99
806135	14	0.6	100	72,99
806128	9	0.6	65	69,99
806111	5	0.6	40	64,99
806104	2.5	0.6	20	59,99

cod	litri	grosime (mm)	inaltime (mm)	lei
806258	15.5	0.7	200	139,99
806241	13	0.7	150	84,99
806234	9	0.6	100	69,99
806227	5.5	0.6	65	54,99
806210	3	0.6	40	49,99
806203	1.5	0.6	20	47,99

cod	litri	grosime (mm)	inaltime (mm)	lei
806357	12.5	0.7	200	99,99
806340	9.5	0.7	150	79,99
806333	6.5	0.6	100	44,99
806326	4	0.6	65	39,99
806319	2	0.6	40	34,99
806302	1	0.6	20	29,99



806449



806548



806647

cod	litri	grosime (mm)	inaltime (mm)	lei
806449	5.7	0.7	150	59,99
806456	7.8	0.7	200	69,99
806432	4	0.6	100	35,99
806425	2.5	0.6	65	32,99
806418	1.5	0.6	40	30,99
806401	0.6	0.6	20	28,99

cod	litri	grosime (mm)	inaltime (mm)	lei
806555	5.5	0.7	200	69,99
806548	4	0.7	150	54,99
806531	2.8	0.6	100	35,99
806524	1.8	0.6	65	32,99

cod	litri	grosime (mm)	inaltime (mm)	lei
806654	3.4	0.7	200	54,99
806647	2.4	0.7	150	34,99
806630	1.6	0.6	100	26,99
806623	1	0.6	65	22,99



806739

cod	litri	grosime (mm)	inaltime (mm)	lei
806739	1	0.7	100	29,99
806722	0.6	0.6	65	16,99



808153

808108

### ADAPTOR IMBINARE VASCHETE

- Pentru montarea vaschetelor Gastronorm in bain-marie, in chafing dish-uri, etc

cod	GN	mm	lei
808108	GN 1/2	325x22x(H)10	<b>15,99</b>
808153	GN 1/1	530x22x(H)10	<b>24,99</b>



806197

### TAVA GASTRONORM PERFORATA

cod	GN	lei
806296	GN 2/3	<b>69,99</b>
806197	GN 1/1	<b>79,99</b>
806395	GN 1/2	<b>49,99</b>
806494	GN 1/3	<b>49,99</b>
806593	GN 1/4	<b>44,99</b>
806692	GN 1/6	<b>34,99</b>

### TAVA PERFORATA GASTRONORM SERIA KITCHEN LINE

1/1



807132

- Partea inferioara perforata.
- Laturi perforate cu o inaltime de 100 mm sau mai mare.

cod	litri	grosime (mm)	inaltime (mm)	lei
807132	14	0.6	100	<b>89,99</b>
807125	9	0.6	65	<b>79,99</b>

- Baza perforata

cod	litri	grosime (mm)	inaltime (mm)	lei
807118	5	0.6	40	<b>69,99</b>

2/3



807224

- Diametru perforatii 4 mm.
- Partea inferioara perforata.

cod	litri	grosime (mm)	inaltime (mm)	lei
807224	5.5	0.6	65	<b>79,99</b>

1/2



807330

- Diametru perforatii 4 mm.
- Partea inferioara perforata.
- Laturi perforate cu o inaltime de 100 mm sau mai mare.

cod	litri	grosime (mm)	inaltime (mm)	lei
807330	6.5	0.6	100	<b>69,99</b>

- Baza perforata

cod	litri	grosime (mm)	inaltime (mm)	lei
807323	4	0.6	65	<b>37,99</b>



806845

### CAPAC GASTRONORM

cod	grosime (mm)	GN	mm	lei
806814	0.7	GN 1/1	530x325	<b>45,99</b>
806821	0.7	GN 2/3	354x325	<b>38,99</b>
806838	0.7	GN 1/2	265x325	<b>27,99</b>
806845	0.7	GN 1/3	325x176	<b>18,99</b>
806852	0.7	GN 1/4	265x162	<b>17,99</b>
806869	0.7	GN 1/6	176x162	<b>15,99</b>
806876	0.7	GN 1/9	176x108	<b>12,99</b>



806968

### CAPAC GASTRONORM CU FANTA PENTRU LINGURA SERVIRE

cod	grosime (mm)	GN	mm	lei
806913	0.7	GN 1/1	530x325	<b>59,99</b>
806920	0.7	GN 2/3	354x325	<b>44,99</b>
806937	0.7	GN 1/2	265x325	<b>39,99</b>
806944	0.7	GN 1/3	325x176	<b>29,99</b>
806951	0.7	GN 1/4	265x162	<b>26,99</b>
806968	0.7	GN 1/6	176x162	<b>23,99</b>
806975	0.7	GN 1/9	176x108	<b>18,99</b>



## TAVI GASTRONORM SERIA BUDGET LINE

- Design foarte solid
- Margini netede, usor de curatat
- Pentru utilizare in cuptoare convecție, frigidera, sisteme bain-marie si chafing dish-uri

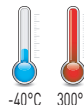

Pentru utilizare la temperaturi de -40 °C/300°C

Rezistent la coroziune (atunci cand este utilizat in mod corespunzator)

Grosime 0,6-0,7 mm

GN 1/1	GN 2/3	GN 1/2	GN 1/3	GN 1/4	GN 1/6	GN 1/9
530x325 mm	354x325 mm	325x265 mm	325x176 mm	265x162 mm	176x162 mm	176x108 mm

1/1



800133

2/3



800232

1/2



800331

cod	litri	inaltime (mm)	lei
800157	28	200	<b>95,99</b>
800140	21	150	<b>83,99</b>
800133	14	100	<b>58,99</b>
800126	9	65	<b>39,99</b>
800119	5	40	<b>39,99</b>
800102	2.5	20	<b>34,99</b>

cod	litri	inaltime (mm)	lei
800225	5.5	65	<b>38,99</b>
800249	13	150	<b>74,99</b>
800232	9	100	<b>49,99</b>
800218	3	40	<b>32,99</b>

cod	litri	inaltime (mm)	lei
800355	12.5	200	<b>66,99</b>
800348	9.5	150	<b>49,99</b>
800331	6.5	100	<b>41,99</b>
800324	4	65	<b>29,99</b>
800317	2	40	<b>24,99</b>
800300	1	20	<b>23,99</b>

1/3



800430

1/4



800539

1/6



800638

cod	litri	inaltime (mm)	lei
800454	7.8	200	<b>51,99</b>
800447	5.7	150	<b>44,99</b>
800430	4	100	<b>32,99</b>
800423	2.5	65	<b>22,99</b>
800416	1.5	40	<b>22,99</b>
800409	0.8	20	<b>19,99</b>

cod	litri	inaltime (mm)	lei
800553	5.5	200	<b>44,99</b>
800546	4	150	<b>39,99</b>
800539	2.8	100	<b>29,99</b>
800522	1.8	65	<b>23,99</b>

cod	litri	inaltime (mm)	lei
800652	3.4	200	<b>45,99</b>
800645	2.4	150	<b>32,99</b>
800638	1.6	100	<b>22,99</b>
800621	1	65	<b>16,99</b>

1/9



800737

cod	litri	inaltime (mm)	lei
800737	1	100	<b>21,99</b>
800720	0.6	65	<b>15,99</b>

## CAPAC CU DISTRIBUTOR PENTRU RECIPIENTE GN

- Carcasa, arc in dozator si sistem mecanic fabricat din otel inoxidabil AISI 304.
- Elementul inferior al dozatorului este fabricat din polipropilena.
- Detasabil: capac, pompa distribuitor.
- Portia de sos distribuita: 35 ml.
- Nu poate fi spalat in masina de spalat vase.
- Potrivit pentru recipiente GN cu o inaltime de 200 mm (nu este inclusa).



cod	GN	mm	lei
558133	GN 1/6	180x165	<b>875,99</b>
558140	GN 1/4	270x165	<b>929,99</b>
558157	GN 1/3	330x180	<b>999,99</b>



558140

## TAVI GASTRONORM CU MANERE SERIA BUDGET LINE



817148



817247

cod	litri	inaltime (mm)	lei
817155	28	200	<b>119,99</b>
817148	21	150	<b>104,99</b>

cod	litri	inaltime (mm)	lei
817254	17	200	<b>104,99</b>
817247	13	150	<b>89,99</b>



817346



817445

cod	litri	inaltime (mm)	lei
817353	12.5	200	<b>79,99</b>
817346	9.5	150	<b>68,99</b>

cod	litri	inaltime (mm)	lei
817452	7.8	200	<b>64,99</b>
817445	5.7	150	<b>58,99</b>



817810

## CAPAC GASTRONORM

cod	GN	mm	lei
817834	GN 1/2	325x265	<b>36,99</b>
817841	GN 1/3	325x176	<b>23,99</b>
817810	GN 1/1	530x325	<b>59,99</b>
817827	GN 2/3	354x325	<b>49,99</b>



## TAVI GASTRONORM DIN POLICARBONAT NEGRU

- Vaschete Gastronorm profesionale de inalta calitate din policarbonat negru
- Nu absorb mirosurile sau aromele
- Rezistent la temperaturi intre -40 °C si 110 °C.

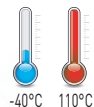

Vezi filmul



Pentru utilizare la temperaturi de -40 °C / 110 °C

Cu gradatie

GN 1/1	GN 2/3	GN 1/2	GN 1/3	GN 1/4	GN 1/6	GN 1/9
530x325 mm	354x325 mm	325x265 mm	325x176 mm	265x162 mm	176x162 mm	176x108 mm

1/1



862209

cod	litri	inaltime (mm)	lei
862216	21	150	99,99
862223	14	100	89,99
862209	9	65	65,99

1/2



862421

cod	litri	inaltime (mm)	lei
862407	12.5	200	64,99
862414	9.5	150	55,99
862421	6.5	100	41,99
862438	4	65	36,99

1/3



862513

cod	litri	inaltime (mm)	lei
862506	7.8	200	50,99
862513	5.7	150	43,99
862520	4	100	34,99
862537	2.5	65	31,99

1/4



862629

cod	litri	inaltime (mm)	lei
862612	4	150	36,99
862629	2.8	100	27,99
862636	1.8	65	24,99

1/6



862711

cod	litri	inaltime (mm)	lei
862704	3.4	200	34,99
862711	2.4	150	31,99
862728	1.6	100	20,99
862735	1	65	17,99

1/9



862827

cod	litri	inaltime (mm)	lei
862827	1	100	14,99

## CAPAC GASTRONORM

cod	GN	mm	lei
862902	GN 1/1	530x325	50,99
862926	GN 1/2	325x265	30,99
862933	GN 1/3	325x176	22,99
862940	GN 1/4	265x162	19,99
862957	GN 1/6	176x162	14,99



## RECIPIENTE DIN GASTRONORM DIN POLICARBONAT ALB

- Recipiente din sticla Gastronorm profesionala de inalta calitate, realizate din policarbonat alb.
- Nu absoarbe mirosuri sau arome.
- Rezistent la temperaturi intre -40 °C si 110 °C.

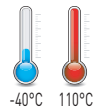

Pentru utilizare la temperaturi de -40 °C / 110 °C

Cu gradatie

GN 1/1	GN 2/3	GN 1/2	GN 1/3	GN 1/4	GN 1/6
530x325 mm	354x325 mm	325x265 mm	325x176 mm	265x162 mm	176x162 mm



862285

cod	litri	inaltime (mm)	lei
862285	9	65	<b>69,99</b>



862476

cod	litri	inaltime (mm)	lei
862483	4	65	<b>36,99</b>
862476	6.5	100	<b>44,99</b>



862575

cod	litri	inaltime (mm)	lei
862568	5.7	150	<b>43,99</b>
862575	4	100	<b>34,99</b>
862582	2.5	65	<b>31,99</b>



862674

cod	litri	inaltime (mm)	lei
862674	2.8	100	<b>29,99</b>
862681	1.8	65	<b>24,99</b>



862773

cod	litri	inaltime (mm)	lei
862766	2.4	150	<b>31,99</b>
862773	1.6	100	<b>20,99</b>
862780	1	65	<b>17,99</b>



862964

### CAPAC GASTRONOM

cod	GN	mm	lei
862919	GN 1/1	530x325	<b>51,99</b>
862964	GN 1/2	265x325	<b>29,99</b>
862971	GN 1/3	325x176	<b>22,99</b>
862988	GN 1/4	265x162	<b>20,99</b>
862995	GN 1/6	176x162	<b>14,99</b>



## TAVI GASTRONORM DIN POLICARBONAT TRANSPARENT

- Vaschete Gastronorm profesionale de inalta calitate din policarbonat transparent
- Nu absorb mirosurile sau aromele
- Rezistent la temperaturi intre -40 °C si 110 °C.

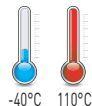

Pentru utilizare la temperaturi de -40°C / 110 °C

Cu gradatie



2/1



861196

cod	litri	inaltime (mm)	lei
861196	58	200	<b>199,99</b>

1/1



861202

cod	litri	inaltime (mm)	lei
861202	24	200	<b>101,99</b>
861219	21	150	<b>82,99</b>
861226	14	100	<b>69,99</b>
861233	9	65	<b>59,99</b>

1/2



861424

cod	litri	inaltime (mm)	lei
861400	12.5	200	<b>55,99</b>
861417	9.5	150	<b>44,99</b>
861424	6.5	100	<b>40,99</b>
861431	4	65	<b>32,99</b>

1/3



861523

cod	litri	inaltime (mm)	lei
861509	7.8	200	<b>44,99</b>
861516	5.7	150	<b>42,99</b>
861523	4	100	<b>32,99</b>
861530	2.5	65	<b>29,99</b>

1/4



861622

cod	litri	inaltime (mm)	lei
861608	5.5	200	<b>39,99</b>
861615	4	150	<b>32,99</b>
861622	2.8	100	<b>29,99</b>
861639	1.8	65	<b>24,99</b>

1/6



861721

cod	litri	inaltime (mm)	lei
861707	3.4	200	<b>29,99</b>
861714	2.4	150	<b>24,99</b>
861721	1.6	100	<b>19,99</b>
861738	1	65	<b>16,99</b>

1/9



861820

cod	litri	inaltime (mm)	lei
861820	1	100	<b>12,99</b>
861837	0.6	65	<b>11,99</b>

864104

### CAPAC GASTRONORM

- Fara fanta
- Potrivite si pentru vaschete Profi Line din otel inoxidabil

cod	GN	mm	lei
864098	GN 2/1	650x530	<b>115,99</b>
864104	GN 1/1	530x325	<b>44,99</b>
864128	GN 1/2	265x325	<b>30,99</b>
864135	GN 1/3	325x176	<b>22,99</b>
864142	GN 1/4	265x162	<b>16,99</b>
864159	GN 1/6	176x162	<b>12,99</b>
864166	GN 1/9	176x108	<b>9,99</b>

868522

### GRATAR DE SCURGER

cod	GN	mm	lei
868522	GN 1/1	467x263	<b>34,99</b>
868546	GN 1/2	265x206	<b>17,99</b>
868553	GN 1/3	266x116	<b>11,99</b>
868577	GN 1/6	118x106	<b>7,99</b>

864203

### CAPAC GASTRONORM

- Fara fanta
- Potrivite si pentru vaschete Profi Line din otel inoxidabil

cod	GN	mm	lei
864210	GN 1/2	265x325	<b>69,99</b>
864203	GN 1/1	530x325	<b>94,99</b>

## TAVI GASTRONORM DIN POLIPROPILENA

- Nu absorb mirosurile sau aromele
- Rezistent la temperaturi între -40 °C și 80 °C.

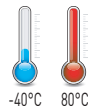

Pentru utilizare la temperaturi de -40 °C / 80 °C

Gradat

GN 1/1	GN 2/3	GN 1/2	GN 1/3	GN 1/4	GN 1/6	GN 1/9
530x325 mm	354x325 mm	325x265 mm	325x176 mm	265x162 mm	176x162 mm	176x108 mm



880012

cod	litri	inaltime (mm)	lei
880005	28	200	<b>68,99</b>
880012	21	150	<b>54,99</b>
880029	14	100	<b>51,49</b>



880111

cod	litri	inaltime (mm)	lei
880104	12.5	200	<b>39,99</b>
880111	9.5	150	<b>33,99</b>
880128	6.5	100	<b>27,99</b>



880210

cod	litri	inaltime (mm)	lei
880203	7.8	200	<b>32,99</b>
880210	5.7	150	<b>27,99</b>
880227	4	100	<b>21,99</b>



880319

cod	litri	inaltime (mm)	lei
880302	5.5	200	<b>29,99</b>
880319	4	150	<b>22,99</b>
880326	2.8	100	<b>18,99</b>



880418

cod	litri	inaltime (mm)	lei
880401	3.4	200	<b>24,99</b>
880418	2.4	150	<b>18,99</b>
880425	1.6	100	<b>13,99</b>



880524

cod	litri	inaltime (mm)	lei
880524	1	100	<b>11,99</b>



880609

### CAPAC GASTRONORM

- Potrivit pentru toate vaschetele HENDI Gastronorm din polipropilena, inclusiv containerele de depozitare HACCP

cod	GN	mm	lei
880609	GN 1/1	530x325	<b>25,99</b>
880616	GN 1/2	325x265	<b>14,99</b>
880623	GN 1/3	325x176	<b>10,29</b>
880630	GN 1/4	265x162	<b>8,99</b>
880647	GN 1/6	176x162	<b>7,99</b>
880654	GN 1/9	176x108	<b>6,49</b>



881811

### CAPACE GASTRONORM ETANSE

- Capacul cu etansare din santopren, dispune de o etansare suficient de puternica pentru a preveni scurgeri atunci cand containerul este inclinat.
- Cu fanta pentru deschidere usoara.



cod	GN	mm	lei
881828	GN 1/3	325x176	<b>32,99</b>
881804	GN 1/1	530x325	<b>59,99</b>
881811	GN 1/2	325x265	<b>42,99</b>
881835	GN 1/4	265x162	<b>28,99</b>
881842	GN 1/6	176x162	<b>23,99</b>
881859	GN 1/9	176x108	<b>21,99</b>



## CONTAINERE DEPOZITARE HACCP

- Doar containere Gastronorm - capace nu sunt incluse
- Inchidere etansa
- Nu absorb mirosurile sau aromele
- Capace si sisteme de prindere capac (verde, galben, albastru, rosu sau violet, conform normelor HACCP) disponibile separat
- Eticheta de monitorizare a procesului de depozitare a alimentelor
- Markerii speciali, ce pot fi stersi, pentru a scrie pe etichete, nu sunt inclusi
- Rezistent la temperaturi intre -40 °C si 80 °C.

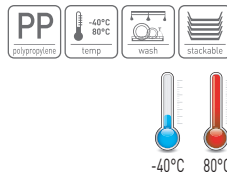

Vezi filmul

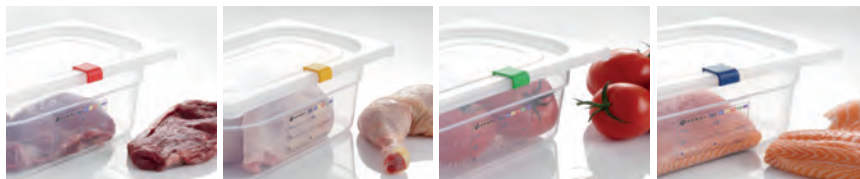

GN 1/1

GN 1/2

GN 1/3

GN 1/4

GN 1/6

GN 1/9

530x325 mm

325x265 mm

325x176 mm

265x162 mm

176x162 mm

176x108 mm

1/1



880050

1/2



880159

cod	litri	inaltime (mm)	lei
880050	28	200	<b>74,99</b>
880067	21	150	<b>59,99</b>
880074	12	100	<b>53,99</b>
880036	9	65	<b>48,99</b>

cod	litri	inaltime (mm)	lei
880159	12.5	200	<b>44,99</b>
880166	9.5	150	<b>32,99</b>
880173	6.5	100	<b>29,99</b>

1/3



880258

cod	litri	inaltime (mm)	lei
880258	7.8	200	<b>39,99</b>
880265	5.7	150	<b>32,99</b>
880272	4	100	<b>26,99</b>
880289	2.5	65	<b>22,99</b>

1/4



880371

cod	litri	inaltime (mm)	lei
880357	5.5	200	<b>34,99</b>
880364	4	150	<b>29,99</b>
880371	2.8	100	<b>24,99</b>
880388	1.8	65	<b>20,99</b>

1/6



880456

cod	litri	inaltime (mm)	lei
880456	3.4	200	<b>25,99</b>
880463	2.4	150	<b>21,99</b>
880470	1.6	100	<b>20,99</b>
880487	1	65	<b>16,99</b>

1/9



880555

cod	litri	inaltime (mm)	lei
880555	0.9	100	<b>16,99</b>
880562	0.6	65	<b>13,99</b>

## CAPAC GASTRONORM

- Potrivit pentru toate vaschetele HENDI Gastronorm din polipropilena, inclusiv containerele de depozitare HACCP

cod	GN	mm	lei
880609	GN 1/1	530x325	<b>25,99</b>
880616	GN 1/2	325x265	<b>14,99</b>
880623	GN 1/3	325x176	<b>10,29</b>
880630	GN 1/4	265x162	<b>8,99</b>
880647	GN 1/6	176x162	<b>7,99</b>
880654	GN 1/9	176x108	<b>6,49</b>



880623

## MARKERI HORECA

- Set de 2 bucati
- Pentru inscripționarea containerelor pentru alimente
- Pot fi stersi

cod	ambalat pe	lei
871546	2	<b>34,99</b>

871546



## CUTIE PENTRU ALIMENTE CU DESPARTITOR

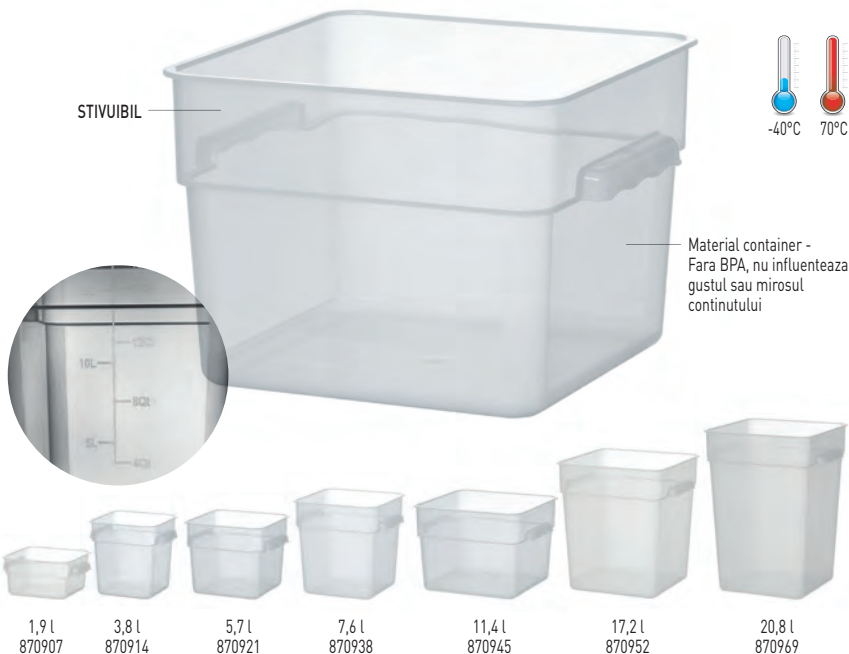

- Destinat depozitarii alimentelor
- Fabricat din polipropilena transparenta
- Inscriptii de masurare a continutului
- Rezistent la temperaturi intre -40°C si +70°C
- Stivuibil
- Potrivit pentru cuptorul cu microunde
- Spalare la masina de vase
- Reciclabil
- Capacul poate fi achizitionat separat

cod	litri	mm	lei
870907	1.9	190x190x(H)195	<b>14,99</b>
870914	3.8	190x190x(H)180	<b>20,99</b>
870921	5.7	235x235x(H)180	<b>27,99</b>
870938	7.6	235x235x(H)230	<b>30,99</b>
870945	11.4	290x290x(H)210	<b>49,99</b>
870952	17.2	290x290x(H)320	<b>59,99</b>
870969	20.8	290x290x(H)400	<b>79,99</b>



### CAPAC PENTRU CUTIE DEPOZITARE ALIMENTE

- Fabricat din polipropilena transparenta
- Rezistent la temperaturi intre -40°C si +70°C
- Stivuibil
- Potrivit pentru cuptorul cu microunde
- Spalare la masina de vase
- Reciclabil

cod	mm	lei
870976	190x190	<b>9,99</b>
870983	235x235	<b>10,99</b>
870990	290x290	<b>15,99</b>

## CUTIE DEPOZITARE OUA HENDI OVOBOX 120

- Destinat depozitarii in siguranta a oualor sterilizate intr-o camera frigorifica - fara riscul de transfer al salmonella in camera frigorifica.
- Recipient perfect transparent din polipropilena - continutul recipientului este intotdeauna vizibil.
- Recipient de dimensiuni GN 2/3, adecvat pentru 4 cofraje cu oua.
- Setul include: recipient, capac, 8 tavi pentru oua.
- Tavi confectionate din PET, care pot fi stivuite, cu taieturi profilate pe ambele parti pentru scoaterea usoara a tavilor din recipient.
- Fiecare tava poate contine 30 de oua (5x6 randuri) - intregul recipient poate contine in total 120 de oua.
- Rezistenta la temperatura: -40°C - +80°C.
- Recipientul si tava pot fi spalate in masina de spalat vase.
- Tavile suplimentare pot fi achizitionate separat.
- ATENȚIE: Ouale trebuie sterilizate inainte de a fi puse pe tavi si in recipient pentru a preveni contaminarea cu salmonella.
- Puneti alternativ tavile de oua in recipient, rotindu-le pe fiecare la 90 de grade fata de cea anterioara.

cod	litri	mm	lei
870785	18	355x325x(H)200	99,99

include

8x

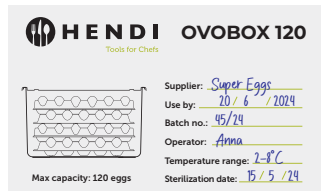

870785

## SET DE 4 TAVI PENTRU OUA PENTRU HENDI OVOBOX 120

- Fabricat din PET.
- Fiecare tava poate contine 30 de oua (5x6 randuri) - intregul set poate tine in total 120 de oua.
- Usor de stivuit.
- Rezistenta la temperatura: -40°C - +80°C.
- Poate fi spalat in masina de spalat vase.
- Recomandat pentru utilizare impreuna cu recipientul cu oua HENDI OVOBOX 120 (cod: 870785).
- ATENȚIE: inainte de a pune oua pe tavi, acestea trebuie sterilizate pentru a preveni contaminarea cu salmonella.

cod	mm	lei
870792	291x288x(H)41	19,99



870792

NOU



# ALERGII ALIMENTARE

Atunci cand preparati alimente pentru clienti cu alergii, este important sa preveniti contaminarea produselor alimentare. Cu ajutorul noii colorii adaugate codurilor HACCP aveti acum instrumente pentru a prepara in siguranta mese pentru persoanele alergice.

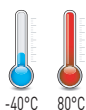

Vezi filmul



1/1



880050

cod	litri	inaltime (mm)	lei
880050	28	200	<b>74,99</b>
880067	21	150	<b>59,99</b>
880074	12	100	<b>53,99</b>
880036	9	65	<b>48,99</b>

1/2



880159

cod	litri	inaltime (mm)	lei
880159	12.5	200	<b>44,99</b>
880166	9.5	150	<b>32,99</b>
880173	6.5	100	<b>29,99</b>

1/3



880258

cod	litri	inaltime (mm)	lei
880258	7.8	200	<b>39,99</b>
880265	5.7	150	<b>32,99</b>
880272	4	100	<b>26,99</b>
880289	2.5	65	<b>22,99</b>

1/4



880371

cod	litri	inaltime (mm)	lei
880357	5.5	200	<b>29,99</b>
880364	4	150	<b>29,99</b>
880371	2.8	100	<b>24,99</b>
880388	1.8	65	<b>20,99</b>

1/6



880456

cod	litri	inaltime (mm)	lei
880456	3.4	200	<b>25,99</b>
880463	2.4	150	<b>21,99</b>
880470	1.6	100	<b>20,99</b>
880487	1	65	<b>16,99</b>

1/9



880555

cod	litri	inaltime (mm)	lei
880555	0.9	100	<b>16,99</b>
880562	0.6	65	<b>13,99</b>



FARA ALERGENI  
FARA LACTOZA



FARA ALERGENI  
FARA GLUTEN



FARA ALERGENI  
FARA OU



FARA ALERGENI  
FARA ALUNE

### CLESTE DE SERVIRE HACCP 250 MM

- Pentru servicii alimentare profesionale - culori pentru piese de mana conforme HACCP

cod	culoare	mm	lei
171882	Mov	(L)250	19,99



881705



171882



### CAPAC GASTRONORM MOV

- Potrivit pentru toate vaschetele HENDI Gastronorm din polipropilena, inclusiv containerele de depozitare HACCP

cod	GN	mm	lei
881705	GN 1/1	530x325	27,99
881712	GN 1/2	325x265	14,99
881729	GN 1/3	325x176	10,99
881736	GN 1/4	265x162	9,99
881743	GN 1/6	176x162	7,99
881750	GN 1/9	176x108	6,99



842478



### CUTITUL BUCATARULUI

cod	grosime (mm)	lungimea lamei (mm)	lungime (mm)	lei
842478	2.5	150	280	25,99

826164



826065



### TOCATOR HACCP

- O parte neteda si o parte cu canelura pe margine  
- Poate fi curatat in masini de spalat profesionale (program scurt)

cod	litri	inaltime (mm)	lei
880159	12.5	200	44,99
880166	9.5	150	32,99
880173	6.5	100	29,99

Pret catalog fara TVA



### CUTITUL BUCATARULUI

cod	grosime (mm)	lungimea lamei (mm)	lungime (mm)	lei
842676	2.5	180	320	26,99
842775	2.5	240	385	29,99

842270



842171



### CUTIT UNIVERSAL

cod	grosime (mm)	lungimea lamei (mm)	lungime (mm)	lei
842270	1.2	90	190	13,99
842171	1.2	100	205	14,99

825570



825662



### TOCATOR HACCP

- Ambele fete recomandate pentru taiere  
- Poate fi curatat in masini de spalat profesionale (program scurt)

cod	litri	inaltime (mm)	lei
880159	12.5	200	44,99
880166	9.5	150	32,99
880173	6.5	100	29,99

## ETICHETE PENTRU SIGURANTA ALIMENTELOR

- Autocolante autoadezive pentru marcarea usoara a semifabricatelor si a produselor finite astfel incat sa indeplineasca standardele de siguranta gastronomica.



850299



850305

### SET DE ETICHETE DE UNICA FOLOSINTA PENTRU SIGURANTA ALIMENTELOR PENTRU FIECARE ZI A SAPTAMANII CU DOZATOR

- Dozatorul este realizat din carton durabil, gros.
- Setul include 2000 buc. de etichete de unica folosinta pentru fiecare zi a saptamanii (14.000 buc.).
- Capacitate: 7 role de etichete.
- Dimensiune eticheta: ø19 mm.
- Inclus in set: dozator, 7 role de etichete pentru fiecare zi a saptamanii.

cod	mm	lei
850299	240x80x(H)100	149,99

### SET DE ETICHETE REUTILIZABILE PENTRU SIGURANTA ALIMENTELOR PENTRU FIECARE ZI A SAPTAMANII CU DOZATOR

- Dozatorul este realizat din carton durabil, gros.
- Setul include 1000 buc. de etichete reutilizabile pentru fiecare zi a saptamanii (7000 buc.).
- Capacitate: 7 role de etichete.
- Dimensiune eticheta: 25x25 mm.
- Inclus in set: dozator, 7 role de etichete pentru fiecare zi a saptamanii.

cod	mm	lei
850305	240x80x(H)100	149,99

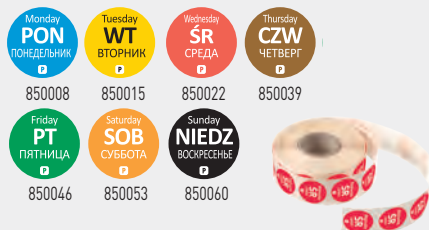

850008

850015

850022

850039

850046

850053

850060



850077

850084

850091

850107

850114

850121

850138

### STICKERE ZILNICE PENTRU ETICHETAREA ALIMENTELOR - DE UNICA FOLOSINTA

- Ideale pentru recipiente de unica folosinta, ambalaje din hartie sau plastic.
- Fiecare zi a saptamanii marcata cu o culoare diferita.
- Eticheta in 3 limbi: poloneza, engleza, rusa.

cod	-	ambalat pe	mm	lei
850336	luni	2000	ø19	21,99
850343	marti	2000	ø19	21,99
850350	miercuri	2000	ø19	21,99
850367	joi	2000	ø19	21,99
850374	vineri	2000	ø19	21,99
850381	sambata	2000	ø19	21,99
850398	duminica	2000	ø19	21,99

### STICKERE ZILNICE PENTRU ETICHETAREA ALIMENTELOR - REUTILIZABILE

- Reutilizabile.
- Usor de indepartat de pe suprafetele din plastic, metal si sticla.
- Eticheta in 3 limbi: poloneza, engleza, rusa.

cod	-	ambalat pe	mm	lei
850404	luni	1000	25x25	21,99
850411	marti	1000	25x25	21,99
850428	miercuri	1000	25x25	21,99
850435	joi	1000	25x25	21,99
850442	vineri	1000	25x25	21,99
850459	sambata	1000	25x25	21,99
850466	duminica	1000	25x25	21,99



850145

### STICKER - „DATA DE VALABILITATE”

- Reutilizabila.
- Usor de indepartat de pe suprafetele din plastic, metal si sticla.
- Eticheta in 3 limbi: poloneza, engleza, rusa.

cod	ambalat pe	mm	lei
850145	500	ø50	39,99

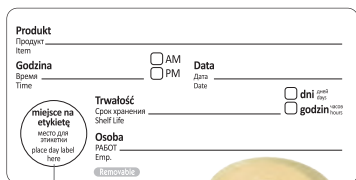

850206

Spatiu pentru etichetele  
850008-850060

### STICKER

- Reutilizabila.
- Usor de indepartat de pe suprafetele din plastic, metal si sticla.
- Eticheta in 3 limbi: poloneza, engleza, rusa.

cod	ambalat pe	mm	lei
850206	500	100x50	46,99



850152

### STICKER R - „FOLOSITI MAI INTAI”

- Reutilizabila.
- Usor de indepartat de pe suprafetele din plastic, metal si sticla. Eticheta in 3 limbi: poloneza, engleza, rusa.

cod	mm	lei
850152	ø50	29,99





Vezi filmul

### TOCATOR HACCP

- Fabricat din polietilena HDPE 500.
- Respecta standardele HACCP.
- Ambele parti potrivite pentru taiere.
- Pot fi curatate in masinile profesionale de spalat vase (program scurt).



**FOARTE  
REZISTENTE**

### TOCATOR HACCP 600X400

cod	culoare	mm	lei
825600	Alb	600x400x(H)18	<b>139,99</b>
825617	Rosu	600x400x(H)18	<b>139,99</b>
825624	Albastru	600x400x(H)18	<b>139,99</b>
825631	Verde	600x400x(H)18	<b>139,99</b>
825648	Maro	600x400x(H)18	<b>139,99</b>
825655	Galben	600x400x(H)18	<b>139,99</b>
825662	Mov	600x400x(H)18	<b>139,99</b>

### TOCATOR HACCP 450X300

cod	culoare	mm	lei
825518	Alb	450x300x(H)13	<b>49,99</b>
825525	Rosu	450x300x(H)13	<b>49,99</b>
825532	Albastru	450x300x(H)13	<b>49,99</b>
825549	Verde	450x300x(H)13	<b>49,99</b>
825556	Maro	450x300x(H)13	<b>49,99</b>
825563	Galben	450x300x(H)13	<b>49,99</b>
825570	Mov	450x300x(H)13	<b>49,99</b>

## TOCATOR HACCP

- Fabricat din polietilena HDPE 500.
- Respecta standardele HACCP.
- Ambele parti potrivite pentru taiere.
- Pot fi curatate in masinile profesionale de spalat vase (program scurt).



Vezi filmul

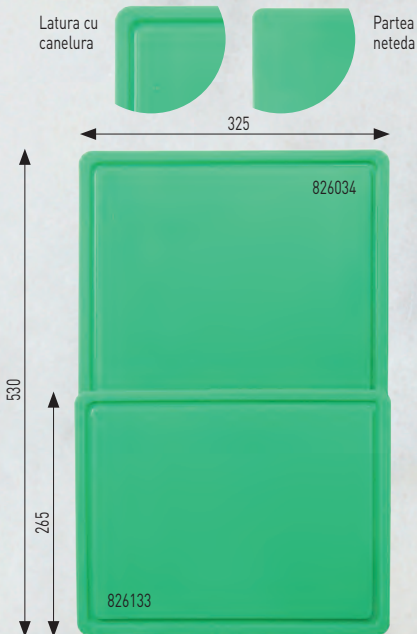

FOARTE  
REZISTENTE



## TOCATOR HACCP GASTRONORM 1/1

- O parte neteda si o parte cu canelura pe margine

cod	culoare	mm	grosime (mm)	lei
826003	Alb	530x325	15	<b>75,99</b>
826010	Rosu	530x325	15	<b>75,99</b>
826027	Albastru	530x325	15	<b>75,99</b>
826034	Verde	530x325	15	<b>75,99</b>
826041	Maro	530x325	15	<b>75,99</b>
826058	Galben	530x325	15	<b>75,99</b>
826065	Mov	530x325	15	<b>75,99</b>

## TOCATOR HACCP GASTRONORM 1/2

- O parte neteda si o parte cu canelura pe margine

cod	culoare	mm	grosime (mm)	lei
826102	Alb	325x265	12	<b>42,99</b>
826119	Rosu	325x265	12	<b>42,99</b>
826126	Albastru	325x265	12	<b>42,99</b>
826133	Verde	325x265	12	<b>42,99</b>
826140	Maro	325x265	12	<b>42,99</b>
826157	Galben	325x265	12	<b>42,99</b>
826164	Mov	325x265	12	<b>42,99</b>
826171	Negru	325x265	12	<b>42,99</b>



826676



## TOCATOR HACCP GASTRONORM 1/1 - SET DE 6 BUCATI

- Set de 6 in culorile rosu, maro, albastru, verde, alb, galben.
- Fiecare tocator are o grosime de 10 mm.

cod	grosime (mm)	mm	lei
826676	10	530x325	<b>346,99</b>



325

530

**NOU****TOCATOR HACCP GN1/1**

- Fabricat din LDPE (polietilena cu densitate mica).
- Ambele parti sunt netede si adecvate pentru utilizare.
- In conformitate cu standardul HACCP.
- Disponibil in 6 culori.

cod	culoare	mm	lei
826805	Alb	530x325x(H)10	<b>49,99</b>
826812	Rosu	530x325x(H)10	<b>49,99</b>
826850	Galben	530x325x(H)10	<b>49,99</b>
826829	Albastru	530x325x(H)10	<b>49,99</b>
826836	Verde	530x325x(H)10	<b>49,99</b>
826843	Maro	530x325x(H)10	<b>49,99</b>

**NOU**

825686

**SET DE 6 PLANSETE DE TAIERE HACCP CU SUPTOR**

- Setul include:
  - 6 tocatoare fabricate din LDPE (polietilena de joasa densitate),
  - 1 suport fabricat din PP (polipropilena).
- Ambele parti ale fiecarui tocator sunt netede si adecvate pentru utilizare.
- Tocatoare codificate pe culori, conforme cu standardele HACCP:
  - planseta albastru recomandata pentru pestele crud,
  - planseta alba pentru produse lactate,
  - planseta maro pentru carne gatita,
  - planseta rosie pentru carne cruda,
  - planseta galbena pentru carnea de pasare,
  - planseta verde pentru legume si fructe.
- Suportul poate fi achizitionat si separat (cod: 825693).
- Poate fi spalat doar in masini de spalat vase profesionale, la un ciclu scurt.

cod	mm	lei
825686	450x300x(H)10	<b>291,99</b>

## TOCATOR UNIVERSAL ALB



826379



826362

### TOCATOR UNIVERSAL

- Fabricat din polietilena HDPE.
- Anti-alunecare

cod	mm	lei
826379	450x300x(H)20	<b>94,99</b>
826386	500x350x(H)18	<b>104,99</b>
826393	600x400x(H)20	<b>149,99</b>

### TOCATOR UNIVERSAL CU CANELURA

- Fabricat din HDPE (polietilena de inalta densitate).
- Manipulati in jurul perimetrului pentru a colecta lichidul - previne scurgerile pe un blat.
- Poate fi spalat doar in masini de spalat vase profesionale, cu un ciclu scurt.

cod	mm	lei
826362	355x250x(H)15	<b>54,99</b>



826485

826348

### TOCATOR CU MANER

- Fabricat din polietilena HDPE.
- Ambele parti potrivite pentru taiere.

cod	culoare	mm	grosime (mm)	lei
826348	Alb	250x150	10	<b>17,99</b>
826478	Negru	250x150	10	<b>19,99</b>
826355	Alb	300x200	10	<b>29,99</b>
826485	Negru	300x200	10	<b>30,99</b>



Flexibil



826300

### TOCATOR SUBTIRE HACCP - SET DE 6 BUCATI

- Set de 6 bucati, culori diferite pentru facilitarea curateniei in bucatarie
- Alb, rosu, albastru, verde, maro, galben
- Flexibil pentru a permite manevrarea usoara a produselor taiate
- Usor de depozitat

cod	mm	lei
826300	380x305	<b>49,99</b>



### SUPPORT ANTI-ALUNECARE

- Suport anti-alunecare multifunctional
- Fabricat din spuma PVC
- Se poate taia la dimensiunea dorita
- Se spala de mana, la 40 ° C
- Nu este potrivit pentru contactul direct cu alimente

cod	mm	lei
598047	1500x300	17,99



### TOCATOR PENTRU BAGHETE

- Din lemn de fag
- Model combinat, 1 parte cu santuri si 1 parte neteda

cod	grosime (mm)	mm	lei
505403	18	530x325	93,99

### TOCATOR PENTRU CARNE

- Tocator solid de fag
- Cu santuri

cod	grosime (mm)	mm	lei
505205	16	390x230	47,99

### TOCATOR PENTRU PAINÉ

- Din lemn de fag, solid

cod	grosime (mm)	mm	lei
505007	14	340x200	39,99

### TOCATOR CU MANER

- Din lemn de fag, solid

cod	grosime (mm)	mm	lei
505106	13	390x160	39,99



### TOCATOR

- Lemn de cauciuc
- Cu manere

cod	mm	lei
506905	530x325x(H)45	149,99
506912	265x325x(H)45	88,99



## TOCATOR DIN FIBRA DE LEMN

- Fabricat din compozit din fibra de lemn, mai dens si mai durabil decat lemnul natural obisnuit.
- Canelura in jurul perimetrului pentru colectarea lichidului - reduce varsarea lichidelor pe blaturi.
- Prevazut cu picioare anti alunecare din silicon.
- Cu un orificiu pentru agatare.
- Disponibil in 3 marimi si 2 culori:
  - negru (coduri: 505755, 505762, 505779),
  - lemn natural (coduri: 505724, 505731, 505748).
- Potrivit pentru masina de spalat vase.

cod	culoare	mm	lei
505724	Maro	300x235x(H)6	<b>75,99</b>
505731	Maro	370x275x(H)6	<b>97,99</b>
505748	Maro	440x325x(H)6	<b>121,99</b>
505755	Negru	300x235x(H)6	<b>75,99</b>
505762	Negru	370x275x(H)6	<b>97,99</b>
505779	Negru	440x325x(H)6	<b>121,99</b>

**NOU**



505731



505762



## TOCATOR PENTRU PAINÉ

- Fabricat din lemn de cauciuc intr-o nuanta inchisa.
- Grila detasabila - grilaje orizontale
- 4 picioare anti-alunecare care asigura stabilitate in timpul taierii.
- Nu poate fi spalat in masina de spalat vase.

cod	grosime (mm)	mm	lei
505502	20	475x322	<b>160,99</b>



505502



## SUPORT TOCATOARE

- Pentru 6 bucati tocatoare cu grosime max. 20 mm

cod	mm	lei
826201	303x211x(H)205	<b>58,99</b>



826201



825693

**NOU**



## SUPORT TOCATOR.

- Fabricat din PP (polipropilena).
- Sustine 6 tocatoare cu o grosime de pana la 2,6 cm.
- Nu poate fi spalat in masina de spalat vase.

cod	mm	lei
825693	320x230x(H)160	<b>45,99</b>



### CUTITE SERIA PROFI LINE

- Toate cutitele sunt produse din otel german inoxidabil; aliajul de otel X50CrMoV15 garanteaza urmatoarele caracteristici:
  - tais ascutit
  - tais durabil in timp
  - usor de ascutit
  - rezistenta ridicata la pete

- Aproximativ 50 de pasi importanti de productie sunt necesari pentru a fabrica fiecare cutit; tehnicilor traditionale si masinilor de precizie li se adauga operatiunile de slefuire si lustruire; manerul combina echilibrul, siguranta, usurinta in folosire cu un aspect exclusiv; fiecare cutit este ambalat individual intr-un blister de prezentare

cod	nr.	nume	grosime (mm)	lungime lama (mm)	lungime (mm)	lei
844205	1	Cutitul bucatarului	3,3	250	390	169,99
844212	2	Cutitul bucatarului	3,3	200	335	135,99
844250	3	Cutit de bucatarie	2	150	265	119,99
844311	4	Cutit feliere	2,7	250	380	139,99
844304	5	Cutit feliere	2,6	200	332	134,99
844267	6	Cutit dezosare, flexibil	2	150	270	109,99
844236	7	Cutit decojire	1,9	90	195	82,99

cod	nr.	nume	grosime (mm)	lungime lama (mm)	lungime (mm)	lei
844328	8	Cutit sunca/somon, flexibil	2,6	300	430	159,99
844298	9	Cutit paine	2,4	215	340	114,99
844281	10	Cutit paine	2,4	215	340	139,99
844335	11	Satar	3	165	300	196,99
844274	12	Cutit Santoku	3	180	310	150,99
844229	13	Furculita pentru carne	9	150	285	119,99
844403	14	Pila diamant ascutit cutite	10,4	310	450	144,99



**S.S.** POM  
stainless steel POM plastic

### CUTITE SERIA KITCHEN LINE

- Realizate dintr-o bucata de otel crom-molibden forjat
- Datorita manereii de inalta calitate, cutitele HENDI sunt durabile si rezistente la coroziune, taisul lamei avand rezistenta mare in timp
- Un design unic al manerului previne patrunderea de reziduuiri

- alimentare intre lama si maner
- Fiecare cutit este ambalat individual intr-un blister de prezentare
- Maner ergonomic negru din material plastic POM



cod	nr.	nume	grosime (mm)	lungime lama (mm)	lungime (mm)	lei
781319	1	Cutitul bucatarului	3.3	200	340	<b>49,99</b>
781357	2	Cutitul bucatarului	3.3	150	285	<b>49,99</b>
781340	3	Cutit feliere	3.3	200	330	<b>46,99</b>
781371	4	Cutit dezosare	2.8	150	285	<b>44,99</b>
781333	5	Cutit paine	3.3	210	335	<b>47,99</b>
781388	6	Cutit de bucatarie	3.5	125	240	<b>32,99</b>

cod	nr.	nume	grosime (mm)	lungime lama (mm)	lungime (mm)	lei
781395	7	Cutit decojire	3	90	200	<b>28,99</b>
781401	8	Foarfece dezosare pasare	5.8	140	260	<b>39,99</b>
781364	9	Furculita pentru carne	1.9	175	290	<b>45,99</b>
781302	10	Satar	2.4	180	300	<b>69,99</b>
781326	11	Cutit sunca/somon	2.4	215	350	<b>44,99</b>
781418	12	Pila ascutit cutite	10	230	350	<b>31,99</b>





## CUTITE GREEN LINE

- Lame de cutit dintr-o singura bucata de otel inoxidabil AISI 420 cu amestec de carbon-molibden-vanadiu, care garanteaza muchii ascutite, rezistente la coroziune, cu duritate ridicata si flexibilitate adecvata.
- Lamele cutitelor au o taietura concava pentru un mai bun echilibru, confort si eficienta.
- Fiecare cutit este finisat manual si ascutit.
- O margine de taiere omogena cu un unghi optim [ $<35^\circ$ ] este testata cu echipamente laser.
- Cutitele se caracterizeaza printr-o durata lunga de viata a lamei si ascutirea foarte usoara.
- Manerul unic, ergonomic, din Santopren cu un amestec de polipropilena are proprietati antiderapante si este mult mai sigur de utilizat decat manerul traditional.
- Poate fi spalat intr-o masina de spalat vase.
- Culoarea verde face cutitul sa fie vizibil pe blatul de lucru.



cod	nr.	nume	grosime (mm)	lungime lama (mm)	lungime (mm)	lei
843802	1	Cutit pentru curatare, curbat	1.5	70	175	<b>45,99</b>
843826	2	Cutit pentru legume	1.5	110	215	<b>45,99</b>
843833	3	Cutit utilitar	2	140	260	<b>56,99</b>
843857	4		2	180	305	<b>66,99</b>
843864	5	Cutit pentru paine	2	200	325	<b>71,99</b>
843888	6		2	260	380	<b>76,99</b>
843895	7		2	300	415	<b>86,99</b>

cod	nr.	nume	grosime (mm)	lungime lama (mm)	lungime (mm)	lei
843918	8	Cutit de sunca	2	280	415	<b>86,99</b>
843932	9	Satar	4	200	325	<b>136,99</b>
843307	10	Cutitul bucatarului	3	220	360	<b>96,99</b>
843949	11		3	260	400	<b>111,99</b>
843956	12	Cutit pentru feliere	3	260	400	<b>129,99</b>
843994	13	Cutit pentru dezosare	3	160	388	<b>76,99</b>
843321	14	Cutit flexibil pentru filetare	2	210	330	<b>84,99</b>

**MANER  
ERGONOMIC  
ANTI-  
ALUNECARE**

## NEGRU - UNIVERSAL

- Maner polipropilena, in conformitate cu normele HACCP



Vezi filmul

Lama alveolara  
pentru taiere  
fara lipire

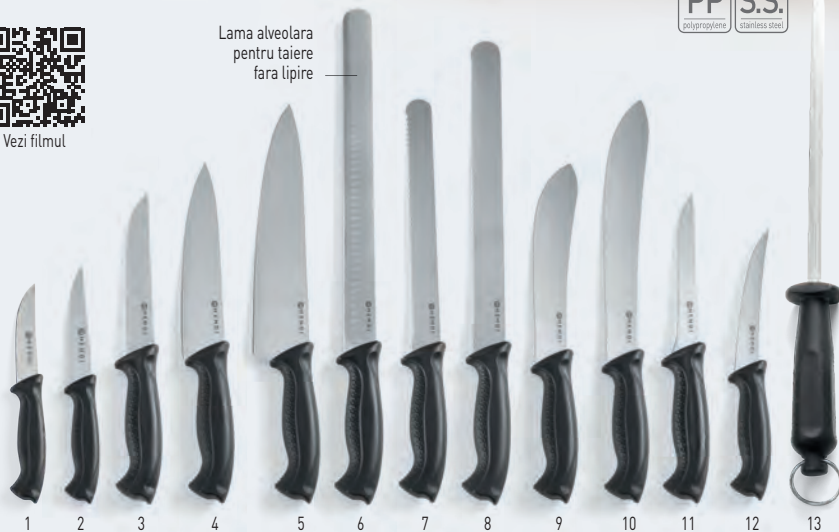

cod	nr.	nume	grosime (mm)	lungime lama (mm)	lungime (mm)	lei	cod	nr.	nume	grosime (mm)	lungime lama (mm)	lungime (mm)	lei
842201	1	Cutit universal	1,2	90	200	<b>13,99</b>	843000	7	Cutit paine	1,5	250	380	<b>25,99</b>
842102	2		1,2	100	210	<b>14,99</b>	843109	8		1,5	300	430	<b>30,99</b>
842409	3		2,5	150	290	<b>22,99</b>	844427	9		2,5	200	330	<b>29,99</b>
842607	4	Cutitul macelarului	2,5	180	320	<b>24,99</b>	844410	10	2,5	250	380	<b>32,99</b>	
842706	5		2,5	240	380	<b>29,99</b>	844441	11	1,8	150	280	<b>27,99</b>	
842904	6	Cutit sunca/somon	1,7	350	490	<b>35,99</b>	844434	12	Cutit filetare	1,8	150	260	<b>24,99</b>
							781418	13	Pila ascutit cutite		230	350	<b>31,99</b>





## MARO - CARNE GATITA

- Maner polipropilena, in conformitate cu normele HACCP
- Fiecare cutit este ambalat individual intr-un blister de prezentare



Vezi filmul



## MARO - CARNE GATITA



cod	nr.		lungimea lamei/ lungime (mm)	grosime (mm)	lei
842669	1	Cutitul bucatarului	180/320	2,5	<b>29,99</b>
842799	2	Cutitul bucatarului	240/385	2,5	<b>34,99</b>
842966	3	Cutit sunca/somon	350/490	1,7	<b>38,99</b>

## ROSU - CARNE CRUDA



cod	nr.		lungimea lamei/ lungime (mm)	grosime (mm)	lei
842423	4	Cutit pentru decupare	150/290	2,5	<b>21,99</b>
842522	5	Cutit pentru filetat	150/300	0,9	<b>22,99</b>
842621	6	Cutitul bucatarului	180/320	2,5	<b>26,99</b>
842720	7	Cutitul bucatarului	240/385	2,5	<b>29,99</b>
842928	8	Cutit sunca/somon	350/490	1,7	<b>34,99</b>

## GALBEN - CARNE DE PASARE



cod	nr.		lungimea lamei/ lungime (mm)	grosime (mm)	lei
842539	9	Cutit pentru filetat	150/300	0,9	<b>22,99</b>
842638	10	Cutitul bucatarului	180/320	2,5	<b>26,99</b>
842737	11	Cutitul bucatarului	240/385	2,5	<b>29,99</b>

## ALBASTRU - PESTE



cod	nr.		lungimea lamei/ lungime (mm)	grosime (mm)	lei
842546	12	Cutit pentru filetat	150/300	0,9	<b>22,99</b>
842645	13	Cutitul bucatarului	180/320	2,5	<b>26,99</b>
842744	14	Cutitul bucatarului	240/385	2,5	<b>29,99</b>

**MANER  
ERGONOMIC  
ANTI-  
ALUNECARE**



Lama alveolara  
pentru taiere  
fara lipire



Lama alveolara  
pentru taiere  
fara lipire



Lama alveolara  
pentru taiere  
fara lipire



### ALB - BRANZETURI SI PAINE



cod	nr.		lungimea lamei/ lungime (mm)	model	grosime (mm)	lei
842256	15	Cutit universal	90/190	scurt	1,2	<b>13,99</b>
842355	16	Cutit universal	130/230	lung	1,2	<b>14,99</b>
842553	17	Cutit pentru filetat	150/300		0,9	<b>22,99</b>
842652	18	Cutitul bucatarului	180/320		2,5	<b>26,99</b>
842751	19	Cutitul bucatarului	240/385		2,5	<b>29,99</b>
843055	20	Cutit paine	250/385		1,5	<b>25,99</b>
843154	21	Cutit paine	300/430		1,5	<b>30,99</b>

### VERDE - FRUCTE SI LEGUME



cod	nr.		lungimea lamei/ lungime (mm)	model	grosime (mm)	lei
842218	22	Cutit universal	90/190	scurt	1,2	<b>12,99</b>
842119	23	Cutit universal	100/205	zimtat	1,2	<b>14,99</b>
842317	24	Cutit universal	130/230	lung	1,2	<b>14,99</b>
842614	25	Cutitul bucatarului	180/320		2,5	<b>26,99</b>
842713	26	Cutitul bucatarului	240/385		2,5	<b>29,99</b>

### MOV - ALERGENI



cod	nr.		lungimea lamei/ lungime (mm)	grosime (mm)	lei
842270	27	Cutit universal	90/190	1,2	<b>13,99</b>
842171	28	Cutit universal	180/205	1,2	<b>14,99</b>
842478	29	Cutit pentru sculptat	150/280	2,5	<b>25,99</b>
842676	30	Cutitul bucatarului	180/320	2,5	<b>26,99</b>
842775	31	Cutitul bucatarului	240/385	2,5	<b>29,99</b>



## SUPRA

- Cutitele Ambrogio Sanelli Supra sunt concepute pentru bucatarii si macelarii profesioniști.
- Lamele sunt fabricate din oțel inoxidabil NITRO-B de înaltă calitate, în care adăugarea moleculelor de azot îmbunătățește semnificativ proprietățile de coroziune și duritatea finală după revenire.
- Setul include un ascuțitor, o furculița și o spatula de patiserie.

- Manere ergonomice realizate din plastic SEBS durabil: flexibil, precum și din punct de vedere al condițiilor meteorologice, ozonului și rezistenței la razele UV.
- Steril, foarte rezistent la impact și coroziune.
- Nu poate fi spălat în mașina de spălat vase.



## SERIA SUPRA



cod	nr.	grosime [mm]	lungimea lamei/ lungime [mm]	lei
S307.012	1	2.8	120/260	<b>74,99</b>
S307.014	2	3	140/280	<b>88,99</b>
S307.016	3	3	160/300	<b>93,99</b>
S301.013	4	3	130/270	<b>75,99</b>
S302.013	5	2	270	<b>75,99</b>
S312.016	6	3	160/300	<b>97,99</b>
S309.020	7	2.8	200/350	<b>124,99</b>
S309.024	8	2.8	240/390	<b>129,99</b>
S309.030	9	2.8	300/450	<b>169,99</b>
S337.018	10	4	180/340	<b>179,99</b>
S347.024	11	2.5	240/390	<b>135,99</b>
S349.016	12	2	160/270	<b>88,99</b>
S349.020	13	2	200/340	<b>103,99</b>
S349.024	14	2.5	240/390	<b>137,99</b>
S349.026	15	2.8	260/410	<b>139,99</b>

cod	nr.	grosime [mm]	lungimea lamei/ lungime [mm]	lei
S349.030	16	2.8	300/450	<b>149,99</b>
S350.018	17	2	180/320	<b>118,99</b>
S350.020	18	2.5	200/340	<b>109,99</b>
S356.028	19	2	280/420	<b>122,99</b>
S358.040	20	3	400/550	<b>149,99</b>
S365.021	21	2	210/350	<b>93,99</b>
S362.026	22	2	260/410	<b>136,99</b>
S363.028	23	2	280/420	<b>123,99</b>
S375.030	24	7	145/300	<b>170,99</b>
S682.011	25	1.3	110/230	<b>34,99</b>
S683.009	26	1.3	90/210	<b>34,99</b>
S690.014	27	1.3	140/260	<b>50,99</b>
S691.007	28	1.3	70/190	<b>32,99</b>
S018.030	29	12	300/430	<b>132,99</b>





## SUPRA COLORE



- Editie speciala a cutitelor superioare Ambrogio Sanelli - Supraculoare. Datorita manerelor lor colorate compatibile cu HACCP, acestea optimizeaza si mai mult munca in bucatarie si faciliteaza utilizarea cutitelor pentru anumite tipuri de alimente - facilitand mentinerea conditiilor de lucru sterile in bucatarie in conformitate cu regulile de igiena si siguranta alimentara si, astfel, siguranta clientilor care mananca.

- Lamele sunt fabricate din otel inoxidabil NITRO-B de inalta calitate.
- Manere realizate din plastic durabil.
- Codare culori in conformitate cu standardul HACCP.
- Setul include un ascutitor.
- Nu poate fi spalat in masina de spalat vase.

## LINIE DE CULOARE SUPERIOARA

NITRO-B  
stainless steel

SEBS

AMBROGIO  
SANELLI  
THE EVOLUTION OF CUTTING



### ROSU - CARNE CRUDA

cod	nr.		grosime (mm)	lungimea lamei/ lungime (mm)	lei
S301.015R	1	Cutit pentru dezosare curbat	3	130/290	<b>90,99</b>
S307.016R	2	Cutit pentru dezosare ingust	3	160/300	<b>93,99</b>



### GALBEN - CARNE DE PASARE

cod	nr.		grosime (mm)	lungimea lamei/ lungime (mm)	lei
S301.013Y	3	Cutit pentru dezosare curbat	3	130/270	<b>76,99</b>
S307.012Y	4	Cutit pentru dezosare curbat	2.8	120/260	<b>74,99</b>
S349.026Y	5	Cutit pentru macelarie	2.8	260/410	<b>139,99</b>



### ALBASTRU - PESTE

cod	nr.		grosime (mm)	lungimea lamei/ lungime (mm)	lei
S309.020L	6	Cutit pentru macelarie	2.8	200/350	<b>124,99</b>
S349.024L	7	Cutit pentru macelarie	2.5	240/390	<b>137,99</b>
S351.018L	8	Cutit filetare peste	1.3	180/310	<b>100,99</b>
S691.007L	9	Cutit pentru legume curbat	1.3	70/190	<b>32,99</b>



### VERDE - FRUCTE SI LEGUME

cod	nr.		grosime (mm)	lungimea lamei/ lungime (mm)	lei
S350.018G	10	Cutit Santoku, lama alveolara	2	180/310	<b>118,99</b>
S682.011G	11	Cutit decojire	1.3	110/230	<b>32,99</b>



### PURPLE - PRELUCRAREA PRODUSELOR FARA ALERGENI

cod	nr.		grosime (mm)	lungimea lamei/ lungime (mm)	lei
S307.014P	12	Cutit pentru dezosare	3	140/280	<b>88,99</b>
S349.030P	13	Cutit pentru macelarie	2.8	300/450	<b>149,99</b>





# hasaki



- HASAKI inseamna „muchie taioasa” in japoneza, prin urmare, exprima perfect numele liniei profesionale Ambrogio Sanelli de cutite in stil japonez.
- Lamele sunt fabricate din otel inoxidabil NITRO-B modificat special (X50CrMoVN15 / AISI440B) – in care adaugarea moleculelor de azot imbunatateste semnificativ protectia la coroziuni si duritatea finala dupa revenire.

- Duritate: 57-58 HRC.
- Conform traditiei japoneze, cutitele sunt ascutite pe o parte, astfel incat alimentele intra in contact cu lama doar pentru o perioada scurta de timp, iar frecarea este redusa la minim.
- Manere perfect echilibrate si confortabile realizate din rasina sintetica POM, nituite.
- Nu poate fi spalat in masina de spalat vase.



cod	nr.		grosime (mm)	lungimea lamei/ lungime (mm)	lei	cod	nr.		grosime (mm)	lungimea lamei/ lungime (mm)	lei
H339.016	1	Cutit Hasaki Usuba	3	160/290	<b>258,99</b>	H341.027	7	Cutit Hasaki Yanagi	2	270/400	<b>259,99</b>
H349.016	2	Cutitul bucatarului	2	160/290	<b>159,99</b>	H341.030	8	Cutit Sashimi	2	300/430	<b>309,99</b>
H349.020	3		2	200/330	<b>214,99</b>	H350.016	9	Cutit Hasaki Santoku, lama alveolara	2	160/290	<b>256,99</b>
H340.016	4	Cutit Hasaki Deba	3	160/290	<b>238,99</b>	H582.010	10	Cutit Hasaki	2	100/200	<b>120,99</b>
H341.021	5	Cutit Hasaki Yanagi	2	210/340	<b>218,99</b>	H582.012	11	universal	2	120/220	<b>124,99</b>
H341.024	6	Cutit Sashimi	2	240/370	<b>204,99</b>						

## CUTITE DECOJIRE - SET DE 6 CULORI

- Maner polipropilena, in conformitate cu normele HACCP



842003

### CUTIT DECOJIRE

- Set cu 6 culori diferite: alb, rosu, albastru, verde, negru si galben
- Fabricate din otel laminat

cod	grosime (mm)	lungimea lamei (mm)	lungime (mm)	lei
842003	1.2	75	175	54,99



842010

### CUTIT DECOJIRE

- Set cu 6 culori diferite: alb, rosu, albastru, verde, negru si galben
- Fabricate din otel laminat

cod	grosime (mm)	lungimea lamei (mm)	lungime (mm)	lei
842010	2.5	90	185	56,99



**NOU**



## CUTITE UTILITARE

- Lama fabricata din otel inoxidabil german X50CRMov-15.
- Maner realizat din polipropilena.
- Grosimea lamei: 1,3 mm.
- Potrivit pentru masina de spalat vase.

cod	nr.		lungimea lamei (mm)	lungime (mm)	lei
842447	1	Cutit pentru decojire curbat	60	170	12,99
842454	2	Cutit decojire	70	180	12,99
842461	3	Cutit pentru decojire, cu varf ascutit	85	195	12,99
842485	4	Cutit pentru friptura, zimtat	117	227	12,99
842492	5	Cutit utilitar	105	215	12,99



842447

842454

842461

842485

842492

## CUTIT PENTRU DECOJIT CU MANER DIN LEMN

- Made in Germany



cod	lungimea lamei (mm)	lungime (mm)	lei
841020	60	165	16,99



841020



## CUTITE DECOJIRE

- Lama fabricata din otel inoxidabil crom-molibden-vanadiu de inalta calitate (X50CrMoV15).
- Maner fabricat din PP (polipropilena).
- Disponibil in 3 culori: negru, rosu, verde.
- Potrivit pentru masina de spalat vase.



**NOU**



cod	nr.		culoare	lungime (mm)	lei
841129	1	Cutit decojire cu lama curbata	neagra	158	15,99
841532	2		rosie	158	15,99
841549	3		verde	158	15,99
841105	4	Cutit pentru decojire	neagra	180	15,99
841556	5		rosie	180	15,99
841563	6		verde	180	15,99
841136	7	Cutit pentru rosii	neagra	214	15,99
841594	8		rosie	214	15,99
841600	9		verde	214	15,99

cod	nr.		culoare	lungime (mm)	lei
841112	10	Cutit pentru decojire	neagra	192	15,99
841570	11		rosie	192	15,99
841587	12		verde	192	15,99
841617	13	Cutit universal	neagra	211	15,99
841624	14		rosie	211	15,99
841631	15		verde	211	15,99

## DECOJITOARE UNIVERSALE

- Lama fabricata din otel inoxidabil.
- Maner fabricat din PP (polipropilena).
- Disponibil in 3 culori: negru, rosu, verde.
- Potrivit pentru masina de spalat vase.



841501

841518

841525

## DECOJITOR UNIVERSAL ORIZONTAL

cod	lungimea lamei (mm)	mm	lei
841501	50	(L)110	23,99
841518	50	(L)110	23,99
841525	50	(L)110	23,99



841228



841235

**NOU**

## DECOJITOR SPARANGHEL

- Corp realizat din otel inoxidabil, lame din otel inoxidabil.
- Maner ergonomic, se potriveste perfect in mana pentru o utilizare confortabila.
- Lame de protectie fabricate din PP (polipropilena) incluse.
- Poate fi spalat in masina de spalat vase.

cod	lungimea lamei (mm)	mm	lei
856406	43	200x50x(H)30	23,99

**NOU**

841471

841488

841495

## DECOJITOR UNIVERSAL CU LAMA ZIMTATA

cod	lungimea lamei (mm)	mm	lei
841471	50	(L)175	23,99
841488	50	(L)175	23,99
841495	50	(L)175	23,99

## DECOJITOR

- Model transversal



cod	lungimea lamei (mm)	lungime (mm)	lei
841228	50	110	10,99

## DECOJITOR

- Model lateral



cod	lungimea lamei (mm)	lungime (mm)	lei
841235	50	150	12,99



856406



856314



856307

Dispozitiv de deschidere pentru sticle integrat



856284

### FOARFECA DEZASAT CARNE PASARE

- Otel carbon de inalta calitate
- Maner moale

cod	mm	lei
856314	(L)240	55,99

### FOARFECA DE BUCATARIE

- Lama zimtata, fabricata din otel inoxidabil.
- Maner realizat din polipropilena, moale la interior.
- Foarfece poate fi dezasamblata in 2 parti pentru o curatare usoara.

cod	mm	lei
856307	(L)200	39,99

### FOARFECA DE BUCATARIE

- Lama zimtata, fabricata din otel inoxidabil.
- Maner realizat din polipropilena, moale la interior.
- Margini zimtate suplimentare in maner pentru indepartarea capacelor de pe sticle.
- Foarfece poate fi dezasamblata in 2 parti pentru o curatare usoara.

cod	mm	lei
856284	(L)225	51,99



1013.000



1555.000



1500.000



### FOARFECA

- Realizata din otel inoxidabil, duritate: 54-55HRC
- Lame inferioare curbate cu dinti taietori ascutiti
- Manerul profilat cu o suprafata aspra face foarfecele sa fie ferm in mana
- Cu incuietore pentru a preveni deschiderea accidentala a instrumentului
- Arcul pentru functionare lina a foarfecelor
- Greutate neta: 0,35 kg

cod	mm	lei
1013.000	(L)250	217,99

### FOARFECE BUCATARIE

- Lama zimtata, fabricata din otel inoxidabil.
- Duritate: 54-55 HRC.
- Maner din nailon (PA6).
- Margini zimtate suplimentare in maner pentru spargerea nucilor.
- Foarfece poate fi dezasamblata in 2 parti pentru o curatare usoara.

cod	mm	lei
1555.000	(L)200	90,99

### FOARFECA DE BUCATARIE

- Lame zimtate din otel inoxidabil.
- Duritate: 54-55HRC.
- Maner profilat din nylon (PA6).
- Greutate neta: 0.081 kg.

cod	mm	lei
1500.000	(L)210	73,99



781913

### CUTIT STRIDII

cod	grosime (mm)	lungimea lamei (mm)	lungime (mm)	lei
781913	2.3	60	170	26,99



781920

### CUTIT DREPT PENTRU STRIDII

cod	grosime (mm)	lungimea lamei (mm)	lungime (mm)	lei
781920	1.6	60	160	13,99



### FELIATOR TRUFE

- Instrumentul perfect pentru taierea trufelor.
- De asemenea, poate fi utilizat pentru felierea si raziura legumelor, branzei si ciocolatei.
- Lama dintata din otel inoxidabil – duritatea 55HRC.
- Carcasa lama fabricata din otel inoxidabil.
- Reglarea lamei cu ajutorul surubului.
- Grosimea sectiunii: de la 0,2 la 3 mm.

cod	mm	lei
229835	220x85	<b>104,99</b>



229835



1721.000



856260



### PRESA USTUROI

- Fabricat din otel inoxidabil – durabil si usor de curatat.
- Forma sa curbata permite strivirea rapida si fara efort.
- Zdrobirea simultana a mai multor catei de usturoi este posibila datorita dimensiunii sale si a plasei perforate.
- Util si pentru ghimbir.
- Diametru orificiu: ø3 mm

cod	mm	lei
856260	105x50	<b>39,99</b>



570715



### PRESA USTUROI

- Constructie solida realizata dintr-o singura bucata de aluminiu.
- PRECAUTIE: Nu poate fi spalat in masina de spalat vase.

cod	mm	lei
570715	175x30	<b>34,99</b>



856123



### PRESA USTUROI

- Usor de curatat
- 2 gratare detasabile

cod	mm	lei
856123	180x25	<b>43,99</b>

513750



### SUPPORT BONURI/FILE

- Fabricat din aluminiu satinat.
- Montat cu suruburi sau benzi de adeziv - incluse.

cod	mm	lei
513736	(L)455	<b>34,99</b>
513705	(L)610	<b>49,99</b>
513712	(L)915	<b>64,99</b>
513743	(L)1015	<b>79,99</b>
513750	(L)1220	<b>89,99</b>



Vezi filmul



### SET 9 PIESE CUTITE

- Fabricate dintr-o singura bucata de otel inoxidabil 3Cr13
- Maner din otel inoxidabil 430 cu un strat anti-alunecare de cauciuc
- Datorita calitatii inalte aceste cutite sunt rezistente la coroziune iar taisul lamei rezista mai mult
- Include:
  - 1 - Cutit decojire - 193 mm
  - 2 - Cutit dezosare - 285 mm
  - 3 - Cutit paine - 333 mm
  - 4 - Cutit sunca/somon - 331 mm
  - 5 - Cutitul bucatarului - 330 mm
  - 6 - Cutitul bucatarului - 370 mm
  - 7 - Cutit Santoku - 336 mm
  - 8 - Ascutitor cutite - 340 mm
  - 9 - Furculita curbata carne - 320 mm
  - 10 - Geanta pentru transport

cod	mm	lei
975770	445x260x(H)65	249,99





**NOU**



### SET DE CUTITE - 4 BUCATI

- Fabricat dintr-o singura bucata de otel inoxidabil 3CR13
- Manopera robusta si rezistenta la coroziune
- Durata lunga de viata a lamei
- Maner conturat care asigura siguranta in timpul utilizarii
- Inclus:
  - 1- Cutit de bucatar - 373 mm
  - 2- Cutit de bucatar - 333 mm
  - 3- Cutit de sunca - 333 mm
  - 4- Cutit de cojit - 195 mm

cod	lei
781029	99,99





### SET UNELTE DECORARE - 6 PIESE



- Contine:
- Lingurita pepene dubla
- Lingurita zimtata
- Cutit lamaie
- Cutit canal
- Cutit mere
- Cutit decorare

cod	mm	lei
856291	280x100x(H)50	184,99



400081



400074



### SET PENTRU PLATING DEDICAT BUCATARILOR, 6 BUC, SATINAT

- Perfect pentru platingul diferitelor feluri de mancare, prajiturilor si a altor deserturi, precum si pentru sushi.
- Fabricat din otel inoxidabil satinat.
- Pensetele sunt perfecte pentru a manipula ingredientele foarte delicate si sunt optimizate pentru o utilizare fara efort.
- Lingura pentru decor cu o duza pentru dozarea precisa a sosurilor.
- Cu husa roll-up compacta pentru protectie impotriva deteriorarii.
- Penseta dreapta: 23 cm
- Pensete curbate: 20 cm
- Penseta cu decalaj (sushi): 21 cm
- Lingura pentru decor: 22,5 cm
- Lingura mica: 15 cm
- Spatuluta: 19 cm
- Poate fi spalata in masina de spalat vase.

cod	mm	lei
400081	255x25x(H)100	199,99

### SET PENTRU PLATING, DEDICAT BUCATARILOR SEFI, 6 BUC, NEGRU

- Perfect pentru platingul diferitelor preparate, prajiturilor si a altor deserturi, precum si pentru sushi.
- Fabricat din otel inoxidabil cu finisaj negru, obtinut prin depunere fizica de vapori.
- Pensetele sunt perfecte pentru a manipula ingredientele foarte delicate si sunt optimizate pentru o utilizare fara efort.
- Lingura pentru decorare cu o duza pentru dozarea precisa a sosurilor.
- Cu husa roll-up compacta pentru protectie impotriva deteriorarii.
- Penseta dreapta: 23 cm
- Pensete curbate: 20 cm
- Penseta cu decalaj (sushi): 21 cm
- Lingura pentru decorare: 22,5 cm
- Lingura mica: 15 cm
- Spatuluta: 19 cm
- Nu poate fi spalata in masina de spalat vase.

cod	mm	lei
400074	255x25x(H)100	219,99

## HUSA PENTRU CUTITE

- Model servieta pentru 6 cutite (lungime maxima 400 mm).
- Cutitele sunt tinute in loc de benzi elastice.
- Carcasa intarita cu plastic pentru o constructie solida.
- Dimensiuni deschise (LxW): 450x400 mm.
- Cutite neincluse.

cod	mm	lei
856383	450x70x(H)110	88,99



## HUSA PENTRU CUTITE

- Carcasa compacta cu un total de 17 sloturi.
- Se potriveste cu 4 cutite cu o lungime maxima de 450 mm si 13 scule mai mici.
- Impartitor intarit cu plastic.
- Cutitele si instrumentele sunt tinute pe loc de benzi elastice.
- Dimensiuni desfasurate: 500x510 mm.
- Cu curea de umar.
- Cutite neincluse.

cod	mm	lei
856390	500x120x(H)225	213,99



## HUSA PENTRU TRANSPORTAT CUTITE

- Geanta pentru 10 cutite, lungime max 450 mm
- Huse suplimentare, cu fermoar sau prindere cu velcro, protejeaza cutitele si impiedica atingerea lor atunci cand geanta este pliata
- 1 buzunar pentru un caiet, 4 buzunare mici pentru carti de vizita si 3 compartimente pentru accesorii mici sau pixuri
- Dimensiuni desfacuta: 515 x 675 mm
- Cureaua de umar poate fi ajustata in intervalul de la 770 mm la 1270 mm
- Se vinde fara cutite

cod	mm	lei
856277	510x50x(H)170	134,99



## MAGNET CUTITE CU AGATATORI

- Cu 2 benzi magnetice

cod	-	mm	lei
820209	3 sustinute	(L)340	34,99
820308	5 sustinute	(L)470	44,99
820407	6 sustinute	(L)620	49,99





NOU



NOU



### CUTITE JAPONeze

- Fabricat in Japonia - design traditional japonez. Toate cutitele de pe aceasta linie formeaza un set complet pentru pregatirea traditionala a sushi-ului.
- Lama fabricata din otel inoxidabil japonez SUS 420J2.
- Maner realizat din lemn poplar.
- Duritatea lamei: aprox. 53 HRC.
- Nu poate fi spalat in masina de spalat vase.

	cod	nr.	nume	grosime (mm)	lungime lama (mm)	lungime (mm)	tei
	845035	1	Santoku	4	165	295	99,99
	845097	2	Deba	3	150	275	150,99 <b>N</b>
	845028	3	Nakiri	4	180	325	145,99
	845059	4	Sashimi	3	210	340	132,99
	845042	5	Sashimi	4	240	370	121,49
	845127	6	Sashimi	2,5	270	405	209,99 <b>N</b>

# HASEGAWA®



## BOL HANGIRI PENTRU AMESTECAREA OREZULUI

- Pentru amestecarea orezului.
- Nucleu din spuma de polistiren (PS), suprafața din polietilena.
- Usor.
- Proprietati antibacteriene.
- Poate fi stivuit.
- Poate fi spalat in masina de spalat vase.

cod	mm	lei
513804	ø480x(H)110	2389,00
513811	ø600x(H)140	3299,00

513859



## PALETA DE OREZ HANGIRI

- Pentru amestecarea orezului sushi.
- Fabricat din polipropilena si nylon.
- Foarte usor.
- Varf ingust.
- Suprafata speciala, ondulata, pentru amestecarea perfecta a orezului amestecat cu otet.
- Poate fi spalata in masina de spalare vase.

cod	mm	lei
513859	400x115	429,99



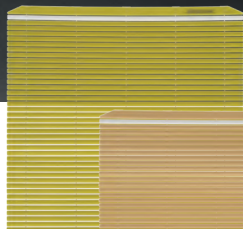

513835

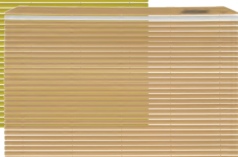

513842



513866

### COVER DE RULARE MAKISU SUSHI

- Pentru sushi rulat.
- Fabricat din polipropilena.
- Imbinari din fibra de nailon.
- Usor de rulat.
- Nu este necesara folie.
- Usor de curatat si uscat.
- Proprietati antibacteriene
- Poate fi spalat in masina de spalat vase

cod	mm	lei
513835	250x240	185,99
513842	250x165	129,99



### PLATOU SUSHI, 600x300 MM

- Fabricat din plastic (elastomer PB) cu un miez interior din lemn protejat cu polietilena (PE).
- Proprietati antibacteriene.
- Cu 30% mai usor decat toate platourile din plastic.
- Nucleul din lemn previne deformarea si asigura durabilitatea placii.
- Proces de productie ecologic - reducerea cantitatii de plastic.
- Poate fi spalat in masina de spalat vase.

cod	mm	lei
513866	600x300	849,99



# HASEGAWA®



513828



## SUPPORT PLATOU SUSHI, 45x50x300 MM

- Fabricat din polietilena (PE).
- Suport elastic antiaderent pentru platou sushi.
- Protectie impotriva alunecarii placii chiar si pe blaturi umede.
- Igiena si ergonomie ridicata.
- Proprietati antibacteriene.
- Posibilitatea de a colecta ingredientele taiate intr-un recipient amplasat sub planseta.
- Poate fi spalata in masina de spalat vase.

cod	mm	lei
513828	300x50x(H)45	199,99



513880

Strat  
abraziv

Strat de  
netezire

## RACLETA PLACII DE TAIERE

- Nucleu fabricat din spuma de polietilena.
- Strat abraziv realizat din oxid de aluminiu si stearat de zinc.
- Produs cu doua fete - proprietati abrazive si de netezire.
- Destinat placilor de taiere Hasegawa si placilor de taiere HENDI HACCP fabricate din lemn sau PE.
- NOTA: Suprafata plansetei de taiere trebuie umezita inainte de a utiliza racleta.

cod	mm	lei
513880	115x50x(H)30	60,99



Vezi filmul



### CUTIT LAMAIE

cod	mm	lei
856031	(L)155	28,99



### CUTIT GRAPEFRUIT

cod	lungimea lamei (mm)	lungime (mm)	lei
856185	100	210	32,99



### CUTIT LEGUME

cod	lungimea lamei (mm)	lungime (mm)	lei
856086	110	220	30,99



### DECOJITOR CITRICE

cod	mm	lei
856055	(L)175	29,99



### LINGURITA PEPENE OVALA

cod	ø	lungime (mm)	lei
856017	ø26	(L)160	29,99



### LINGURITA ZIMTATA

cod	ø	lungime (mm)	lei
856024	ø22	(L)150	27,99



### LINGURITA PEPENE DUBLA

cod	mm	lei
856000	ø 22-25 mm (L)165	39,99



### CUTIT CANAL

cod	mm	lei
856048	(L)155	24,99



### CUTIT MERE

cod	ø	lungime (mm)	lei
856079	ø20	(L)215	27,99



### CUTIT TAIERE ALUAT - LAMA ZIMTATA

cod	ø	lungime (mm)	lei
856154	ø60	(L)188	29,99



### CUTIT UNT

- O lama zimtata.

cod	mm	lei
856192	(L)190	31,99



### CUTIT DE INTINS - ZIMTAT

cod	lungimea lamei (mm)	lungime (mm)	lei
855768	85	210	22,99



### DECOJITOR CARTOFI

cod	lungimea lamei (mm)	lungime (mm)	lei
856178	65	175	22,99



### CUTIT DECORARE

cod	lungimea lamei (mm)	lungime (mm)	lei
856062	90	200	32,99



### CUTIT PENTRU ROSII

cod	lungimea lamei (mm)	lungime (mm)	lei
856253	110	224	35,99



### CUTIT BRANZETURI

cod	mm	lei
856208	(L)200	34,99



### CUTIT PENTRU FELIAT BRANZETURI MOI

cod	mm	lei
856215	(L)160	29,99



### RAZATOARE BRANZETURI

cod	mm	lei
856222	(L)170	32,99



### CUTIT PENTRU BRANZETURI MOI

cod	lungimea lamei (mm)	lungime (mm)	lei
856246	160	270	37,99



Vezi filmul



### CUTIT PENTRU BRANZETURI TARI

cod	lungimea lamei (mm)	lungime (mm)	lei
856239	130	250	39,99



### FELIATOR PIZZA

cod	ø	lungime (mm)	lei
617007	ø100	(L)230	15,99



### FELIATOR PIZZA

- Lama din otel inoxidabil, maner din polipropilena.
- Cu sistemul de codare color HACCP, functioneaza cu clipsuri usor de amplasat.

cod	ø	lungime (mm)	lei
617014	ø100	(L)230	35,99



### SISTEM GHIDAJ IMBUNATATIT

Sistem ghidaj ranforsat cu adancime mare, pentru a ghida lama in timpul ascutirii

### VERSATILITATE - ZONA DE SLEFIT LARGA

Permite ascutirea de lame foarte groase si diferite tipuri de cutit

### 20° - ASCUTIRE PE AMBELE FETE

Unghiul perfect pentru toate tipurile de cutite

### DISCURI ABRASIVE SI DE LUSTRIRE

Intr-un singur proces, ascutit cu un disc de diamant si unul neted ceramic



820643

### ECONOMISIRE

Puteti inlocui pietrele de slefuire fara ajutorul unui tehnician autorizat, simplu si usor

### DURABILITATE

Un motor puternic cu un sistem de racire excelent

### LUCREAZA IN SIGURANTA

Patru picioare din cauciu impiedica ascutorul sa se miste pe blatul de lucru

### ASCUTOR ELECTRIC PENTRU CUTITE

- Recomandat pentru utilizare in toate bucatariile profesionale.
- Pentru ascutirea diferitelor tipuri de cutite: pentru carne, peste, legume si fructe.
- Clarificare eficienta si precisa intr-un singur pas.
- Material abraziv - diamant.
- Roti contralaterale.
- Ascutiti simultan ambele parti ale lamei in unghiul drept.
- Timp de ascutire a lamei de pana la 15 cm: aprox. 3 secunde.
- Timp de ascutire a lamei de pana la 25 cm: aprox. 5 secunde.
- Inlocuire usoara a captuselii abrazive.

cod	V	W	mm	lei
820643	230	75	160x205x(H)185	669,99



224403



Vezi filmul

ABS  
plastic

### DISPOZITIV PENTRU ASCUTIT CUTITE

- Potrivit pentru o ascutire rapida si usoara a cutitelor
- Smirghel usor de schimbat
- Potrivit pentru toate tipurile de cutite pentru carne, peste, legume si fructe

cod	V	W	mm	lei
224403	230	50	295x110x(H)110	871,99
224410	Smirghel pentru ascutorul cutite		50x200	24,99

CERAMIC  
[ceramic]:  
tije galvanizate  
incrucisate pentru  
cutite ceramice

COARSE [aspru]:  
dispozitiv de  
ascutire din  
carbura pentru  
o muchie precisa  
de fiecare data

FINE [fin]:  
tije ceramice  
incrucisate  
pentru ajustarea  
profesionala  
a taisului



820612

### DISPOZITIV ASCUTIT CUTITE

- Manerul ergonomic si baza anti-alunecare ofera siguranta si confort
- 3 functii pentru ascutirea tuturor tipurilor de cutite, chiar si pe cele ceramice
- A nu se folosi pentru ascutirea lamelor zimtate sau foarfecelor



cod	mm	lei
820612	200x46x(H)75	40,99

MODEL  
NOU



820605

### DISPOZITIV ASCUTIT CUTITE

- Cu protectie pentru degete
- Placa de carbura folosita la ascutire poate fi utilizata pe ambele parti

cod	mm	lei
820605	140x15x(H)65	59,99

### PIATRA DE ASCUTIT JAPONeza HENDI DE LA NANIWA

- Piatra cu doua fete este alcatuita din 2 placi cu 2 dimensiuni diferite de granulatie:
  - 220/1000 (820667).
  - 1000/3000 (820674).
- Granulatie - cu intrebuintarile acesteia:
  - 220: macinarea si regenerarea marginilor lamei.
  - 1000: ascutire de baza a lamei.
  - 3000: lustruirea si finisarea marginilor lamei.
- Inainte de utilizare, umeziti piatra cu apa.
- Setul include un recipient din plastic pentru depozitarea in siguranta.



NANIWA®

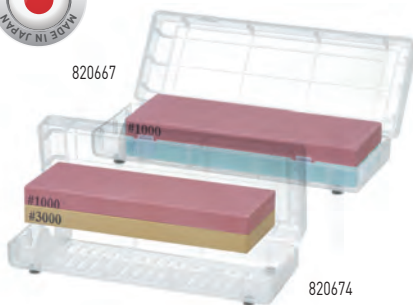

820667

820674

cod	mm	lei
820667	185x65x(H)30	123,99
820674	185x65x(H)30	132,99

### PIATRA DE ASCUTIT JAPONeza

- Piatra cu doua fete consta din 2 placi cu diferite dimensiuni de granulatie: 280/1000.
- Scopul granulatiei diferite:
  - 280: regenerarea marginilor lamei,
  - 1000: ascutirea de baza a lamei.
- Inainte de utilizare, umeziti piatra cu apa.

NOU



845134

cod	mm	lei
845134	180x50x(H)40	349,99

**niroflex**  
premium protection



**NOU**

GS381120000



### MANUSA DE PROTECTIE IMPOTRIVA TAIERII

- Usoara, fabricata din inele sudate din otel inoxidabil cu diametrul de, 4 mm si grosimea de 0,5 mm.
- Cu sistem brevetat de reglare automata a arcurilor de tensionare, fabricat din otel inoxidabil.
- Potrivit pentru mana dreapta si stanga.
- Poate fi spalat intr-o masina de spalat (tumbler).
- Marime: M.

cod	mm	lei
GS381120000	(L)220	466,99

**niroflex**  
premium protection



**NOU**

HA0000003960-08



### MANUSA DE PROTECTIE IMPOTRIVA TAIERII BLUECUT COMFORT

- Fabricat din Brinix – fir brevetat din otel inoxidabil. Nu contine fibra de sticla – nu exista niciun pericol ca particulele de sticla sa se transfere in alimente.
- Poate fi spalat intr-o masina de spalat, la o temperatura de pana la 85°C, nu se micsoareaza si nu se deformeaza.
- Nivel de protectie impotriva taierii: F (conform EN 388:2016).
- Grosime: mediu, tesere 10.
- Potrivit pentru mana dreapta si stanga.
- Marime: M.

cod	mm	lei
HA0000003960-08	(L)240	64,99



556641

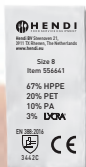

### MANUSI REZISTENTE LA TAIERE - 2 BUCATI

- Oferă protecție pentru manipularea accesoriilor ascuțite în bucătăria profesională, cum ar fi cutitele de bucătărie
- Amestecul de HPPE, fibre de poliester și nailon face ca aceste manusi sa fie durabile si confortabile
- Nivel 4 rezistenta la taiere
- Nivel 3 rezistenta la abraziune

cod	ambalat pe	lei
556641	2	49,99



556665



### MANUSA PENTRU STRIDII

- Constă din 2 manusi, partea interioara din bumbac si partea exteriora cu mail.
- Partea exteriora din otel inoxidabil, rezistenta, rezistenta la taiere si contact alimentar aprobat.
- Partea interioara din bumbac moale si confortabila.
- Potrivit pentru utilizare la dreapta si la stanga.

cod	-	mm	lei
556672	L	(L)330	129,99
556665	M	(L)305	129,99



### DESFACATOR DE CONSERVE KITCHEN LINE

- Include un suport pentru masa.
- Adecvat pentru blaturi de lucru cu o grosime maxima de 55 mm.
- Deschide conservele cu inaltimea maxima de 335 mm.

cod	mm	lei
690000	250x115x(H)550	369,99

690000



### DESCHIZATOR CONSERVE

cod	mm	lei
856116	(L)180	34,49



856116



### DESFACATOR PENTRU CONSERVE

- Acest deschizator de conserve poate indeparta capacul fara a lasa marginile ascutite si ofera posibilitatea de a plasa capacul inapoi pe cutie.
- Mecanismul de taiere functioneaza prin taierea partii laterale a cutiei chiar sub capac.

cod	mm	lei
856161	(L)190	41,99



856161





**NOU**



237922

### MANDOLINA JAPONEZA SAMURAI

- Constructie robusta: elemente fabricate din otel inoxidabil, ABS si polipropilena.
- Suprafata plata din otel este impartita in 2 parti, care pot fi deschise pentru acces usor la lame, in vederea reglarii, indepartarii sau curatarii acestora.
- Suprafata are un strat antiaderent din PTFE care faciliteaza taierea usoara (legume/fructele gliseaza lin).
- Lame extrem de ascutite in cateva variante care ofera diferite efecte de taiere – dar intotdeauna foarte precise si consecvente:
  - 2 lame plate situate pe o piesa inversata: lama neteda sau zimtata,
  - rola detasabila si rotativa cu lame zimtate; grosimea si tipul de taiere pot fi reglate cu usurinta cu un buton: de la 0,5 mm la 9 mm, felii sau julienne.
- Lamele plate sunt amplasate la un unghi pentru un proces de taiere si mai rapid si mai convenabil.

- Rola prevazuta cu protectie – blocata in locul sau, care nu. Pozitia pentru scoaterea rolei este marcata cu butonul rotativ.
- Carligul bolului si picioarele anti-alunecare sunt fabricate din cauciu termoplasic (TPR), asigurand stabilitate completa in timpul functionarii.
- Cu un picior (suport) lat retractabil suplimentar – confort ridicat la utilizare, este posibil sa taiati legumele tinand mandolina in mana sau atunci cand este asezata pe blatul de lucru la un unghi de 45°.
- Accesoriiile care asigura functionarea in siguranta sunt incluse in set:
  - protectie/suport pentru degete, pentru protejarea degetelor si mentinerea legumelor/fructelor cu 6 tepi subtiri,
  - protectie lama confectionata din material sintetic pentru fixarea lamei exterioare.

cod	mm	lei
237922	395x165x(H)115	139,99

**MODEL NOU**



222652



### MANDOLINA

- Lame, suprafete de taiere (unde gliseaza legumele) si corp din otel inoxidabil.
- Maner si buton fabricate din ABS.
- Grosimea de taiere a lamei plate: 1-9 mm, reglabila cu un buton mare pe lateral.
- Protectie: lama este blocata in pozitie si nu provoaca pericolul de cadere. Pozitia pentru scoaterea lamei este marcata pe buton.
- Cu un suport retractabil integrat, cu un picior anti-alunecare fabricat din cauciu termoplasic (TPR).
- Prevazut cu:
  - lama plata pentru taierea felii subtiri,

- 2 lame zimtate inlocuibile fabricate din otel inoxidabil AISI 304, pentru taierea julienne cu o grosime de 4,5 mm sau 9 mm,
- protectie pentru degete din polipropilena, pentru protejarea degetelor si mentinerea legumelor/fructelor cu 6 tepi subtiri (varfuri fabricate din otel inoxidabil AISI 304).
- Poate fi spalat in masina de spalat vase.

cod	mm	lei
222652	418x135x(H)135	279,99



## MANDOLINA TIP V

- Confectionat din plastic ABS si PP negru
- Include 5 lame din otel inoxidabil de inalta calitate
- Suport pliabil cu picioare din cauciuc
- Lama taiere in forma de V
- Lamele pentru julienne si cartofi de 6 mm sau 9 mm
- Grosimea feliei reglabila de la 1 mm la 9 mm
- Sistem de prindere cu ace metalice pentru produs
- Inaltime 140 mm (cu suportul desfasurat)

cod	mm	lei
222614	130x335x(H)75	99,99



Vezi filmul



Lama taietoare in forma de V pentru feliere rapida

222614



222676

MODEL NOU



Vezi filmul

## MANDOLINA TIP V

- Fabricat din otel inoxidabil AISI 304 si ABS.
- Lama principala in forma de V din otel inoxidabil.
- Lame julienne din otel inoxidabil AISI 304.
- 3 tampoane pentru modificarea grosimii felierii: 1,5 mm, 2,5 mm si 3,5 mm.
- 2 tampoane cu lame pentru taierea fasii julienne: 3,5 mm si 7 mm.
- Grosimea de taiere este in relief pe fiecare tampon.
- Inlocuirea rapida a placutelor cu un singur buton de blocare/eliberare.
- Stand rabatabil integrat - un picior larg anti-alunecare acoperit cu cauciuc; mandolina poate fi folosita in timp ce este tinuta in mana sau asezata pe un blat.

- Inclus in set:
  - cutie de depozitare a lamelor,
  - aparatoare din polipropilena si suport pentru legume cu 6 tepi subtiri (tepi din otel inoxidabil AISI 304),
  - scut pentru lama din material sintetic pentru acoperirea lamei "V".
- Se poate spala in masina de spalat vase.

cod	mm	lei
222676	405x135x(H)145	239,99





## MANDOLINE JAPONEZE HENDI SHŌGUN 将軍

- Lame fabricate din otel inoxidabil japonez SUS 420J2.
- Corp realizat din ABS.
- Reglare cursiva si usoara a grosimii de taiere: 1-5 mm.
- Prevazut cu:
  - lama plata, incorporata, care poate taia felii foarte subtiri, aproape transparente,



- protectie pentru degete/suport din polipropilena, pentru protejarea degetelor si mentinerea legumelor/fructelor in timpul taierii.
- Nu poate fi spalat in masina de spalat vase.



221280



**NOU**

## MANDOLINA JAPONEZA HENDI SHŌGUN 将軍

- Inclus: 3 lame zimtate pentru taierea julienne: 1 mm, 2 mm, 8 mm grosime.

cod	mm	lei
221280	380x158x(H)47	214,99



1 mm



2 mm



8 mm



grosime 1-5 mm



221297

## MANDOLINA JAPONEZA HENDI SHŌGUN PRO 将軍 PRO

- Suprafata de taiere lata adecvata pentru legume si fructe mari.

cod	mm	lei
221297	380x180x(H)45	232,99



**NOU**



grosime 1-5 mm





Rifluri extrem de ascutite,  
taiate cu laser

PP 18/8  
polipropilena stainless steel



Vezi filmul



856352

856369

856376



856321

856338

856345

## RAZATOARE

- Lame de taiere de inalta precizie, extrem de ascutite

cod	-	lungimea lamei (mm)	mm	lei
856352	fina	220	35x405	49,99
856369	grosiera	220	35x405	49,99
856376	fasii	220	35x410	49,99

## RAZATOARE

- Lame de taiere de inalta precizie, extrem de ascutite

cod	-	lungimea lamei (mm)	mm	lei
856321	grosiera	134	65x330	45,99
856338	fasii	135	65x330	42,99
856345	raziure	134	65x330	45,99



443002



Vezi filmul

844366



844359

## RAZATOARE CU 4 FETE

cod	mm	lei
443002	90x65x(H)200	24,99

## CUTIT PENTRU TOCAT

cod	-	mm	lei
844359	o singura lama	(L)215	58,99
844366	lama dubla	(L)215	84,99



Placa de montare speciala permite scoaterea si curatarea cu usurinta



Vezi filmul



## TAIETOR CARTOFI PRAJITI (FRENCH)

- Cutite din otel inoxidabil
- Contine 4 cutite: 6, 9 si 13 mm precum si cutit pentru taiere in 8 bucati
- Se monteaza pe masa de lucru sau pe perete
- Maner acoperit cu plastic pentru o priza mai buna
- Placa de montare speciala permite demontare si curatarea facila
- Picioarele cu cauciuc confera o stabilitate sporita la utilizarea pe o masa



cod	mm	lei
630402	430x168x(H)290	579,99



Cu piciorus ventuza

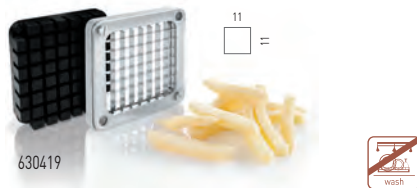

630419

## CUTIT PENTRU TAIETORUL DE CARTOFI PRAJITI 11 MM

- Potrivit pentru Taietorul de cartofi HENDI630402.
- Vine impreuna cu placa de presare.

cod	lei
630419	49,99





 **sammic**

Echipamente pentru  
procesarea rapida  
a alimentelor



## APARAT MANUAL PENTRU TAIEREA CARTOFILOR DIN SERIA CF-5

- Un dispozitiv pentru felierea cartofilor pentru prajit si a altor legume si fructe tari
- Solutia perfecta pentru restaurante mari sau mici
- Include o presa cu cutite pentru cartofi prajiti de 10x10 mm
- Maner extins si arcuri flexibile asigura rezultate optime cu efort minim
- Corpul realizat din aluminiu, manere, piulite si suruburi din otel inoxidabil
- Baza echipata cu ventuze care asigura stabilitatea
- Posibilitatea de curatare usoara pentru inlocuirea seturilor de prese cu: 8x8 si 12x12 mm (optional)
- Greutate 4 kg

cod	productivitate (kg/h)	mm	lei
1020061	100-150	280x512x(H)735 (cu manerul ridicat)	<b>1749,00</b>
1020065		Set cu cutit 8x8 mm	<b>399,99</b>
1020070		Set cu cutit 10x10 mm	<b>399,99</b>
1020075		Set cu cutit 12x12 mm	<b>399,99</b>

**sammic**



570104



### TAIETOR OUA - DREPTUNGIULAR

cod	mm	lei
570104	130x85x(H)30	<b>34,99</b>



570012



### TAIETOR OUA - OVAL

cod	mm	lei
570012	120x115x(H)35	<b>44,99</b>

### OCHELARI PROTECTIE

- Purtați acești ochelari în timpul tăierii cepei pentru a preveni lacrimarea

cod	mm	lei
570906	150x160x(H)45	<b>44,99</b>

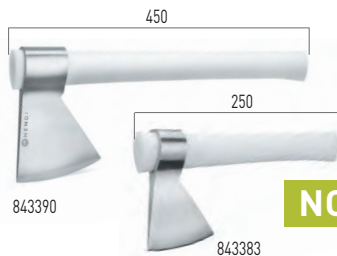

570906

**NOU****SECURE PENTRU CARNE**

- Lama fabricata din otel inoxidabil.
- Maner realizat din PE (polietilena) – spre deosebire de manererele din lemn, acesta nu se rupe sau crapa si nu lasa aschii.
- Poate fi spalat in masina de spalat vase.



cod	lungimea lamei (mm)	lungime (mm)	lei
843390	125	450	<b>456,29</b>
843383	79	250	<b>349,99</b>

**BUTUC LEMN FARA SUPORT**

- Fabricat din lemn de fag

cod	mm	lei
505632	500x400x(H)150	<b>869,99</b>
505649	500x400x(H)200	<b>1109,00</b>

**BUTUC LEMN PE SUPORT DIN LEMN**

- Fabricat din lemn de fag
- Inaltime suport 720 mm

cod	mm	lei
505618	400x400x(H)110	<b>730,99</b>
505625	400x400x(H)150	<b>839,99</b>
505694	500x400x(H)150	<b>1029,00</b>
506011	500x400x(H)200	<b>1209,00</b>

**BUTUC DIN POLIETILENA**

- Fabricat din polietilena HDPE500
- Cadru armat din otel inoxidabil

cod	-	mm	lei
505687	505656+505670	500x400x(H)800	<b>819,99</b>
505656	Butuc macelarie	500x400x(H)50	<b>254,99</b>
505663	HDPE	500x400x(H)80	<b>456,99</b>
505670	Support butuc	500x400x(H)750	<b>611,99</b>
505144	505663 + 505670	500x400x(H)830	<b>1029,00</b>



559291

### PLASA PENTRU CARNE

- Fabricat din fir de poliester si elastic.
- Antiaderent si elastic.
- Lungime: 50 m
- Dimensiuni disponibile:
  - 125x32x3 (cod: 559260)latime: 125 mm numar de orificii pe perimetru: 32
  - 125x48 (cod: 559277)latime: 125 mm numar de orificii pe perimetru: 48
  - 160x32x4 (cod: 559284)latime: 160 mm numar de orificii pe perimetru: 32
  - 200x48 (cod: 559291)latime: 200 mmnumar de orificii pe perimetru: 48

cod	ø	lungime (mm)	lei
559277	ø190	ø190x(H)125	<b>69,99</b>
559260	ø190	ø190x(H)125	<b>72,99</b>
559284	ø190	ø190x(H)160	<b>79,99</b>
559291	ø190	ø190x(H)200	<b>93,99</b>

### PLASA PENTRU CARNE

- Fabricata din poliester elastic
- Antiaderenta si flexibila
- Lungime: 5m



**NOU**

cod	ø	lungime (mm)	lei
559307	ø65	ø65x(H)125	<b>16,99</b>



559239

### SFOARA

- Bobina cu 200 g de sfoara
- Fabricata din bumbac nealbit
- Cca 132 m

cod	-	lei
559239	132 m	<b>29,99</b>

513538



Pret catalog fara TVA



559246

### SFOARA

- Destinat coacerii, suspendarii preparatelor din carne si a altor produse pentru a le conferi o forma uniforma inainte de afumare sau aburire
- Firul este realizat din fibre de bumbac alb, intarit cu fibre de poliester.
- Grosime dubla: tex 1480.
- Putere dubla: 19 (+/-5%) [DAN].
- Scop:- gatire 2,5 h - 90°C.- fumat: 3 h - 150°C.
- Fara metale grele.
- Are un certificat PZH (Institutul National de Igiena) si o declaratie de conformitate.

cod	-	lei
559246	42 m	<b>8,99</b>
559253	90 m	<b>11,99</b>



559208

### SFOARA

- Bobina cu 100 g de sfoara
- Fabricata din bumbac nealbit

code	-	lei
559208	70 m	<b>18,99</b>
559222	144 m	<b>36,99</b>

### CARLIGE MACELARIE - UN SET DE 4 CARLIGE



cod	mm	lei
513538	90x4	<b>20,99</b>
513545	110x5	<b>23,99</b>
513552	130x5	<b>26,99</b>
513569	150x6	<b>32,99</b>

## APARATE DE FRAGEZIRE CARNE



Suprafata  
cu zimti pentru  
porc si vita

Suprafata neteda  
pentru peste  
si carne de pasare

513002



Vezi filmul



### CIOCAN PENTRU FRAGEZIREA CARNII

- Maner solid
- Zimti pentru carne de vita si de porc
- Suprafata neteda pentru carne de pasare si peste

cod	mm	lei
513002	(L)260	<b>35,99</b>



513071

### CIOCAN PENTRU FRAGEZIREA CARNII CU LAME

- Combina un fragezitor de carne cu un ciocan traditional
- Fragezeste perfect carnea si o aplatizeaza in acelasi timp
- 56 de lame in 4 randuri de 14, fabricate din otel inoxidabil
- Lame cu latimea de 2,6 mm, cu o adancime maxima de taiere de aprox. 18 mm
- Greutate: 350 g

cod	-	mm	lei
513071	56 de lame	280x57x(H)70	<b>139,99</b>



843451

843499

Maner proiectat  
special



Vezi filmul



### DISPOZITIV FRAGEZIRE CARNE PROFI LINE

- Instrument modern si eficient pentru prelucrarea mecanica a carnilor, lamele verticale reduc lungimea fibrelor din carne
- Fragezeste perfect carnea si o aplatizeaza in acelasi timp
- Timpul de marinare poate fi redus cu pana la 25% deoarece suprafata de contact a carnilor cu condimentele este crescuta semnificativ
- In timpul prajirii sosurile patrund mai usor in carne
- Arcuri moi, o utilizare mai usoara, un rezultat mai bun

cod	culoare	mm	lei
843499	Negru	42x150x(H)118	<b>94,99</b>
843451	Rosu	42x150x(H)118	<b>94,99</b>
843468	Alb	42x150x(H)118	<b>94,99</b>

51 de lame din otel inoxidabil  
pentru taierea carnilor

Bucati in forma de val  
pentru a aplatiza carnea





extensie  
duza curbata

duza cu jet  
rotund

duza plata



270882

## PULVERIZATOR ELECTRIC PENTRU ALIMENTE

- Piston fabricat din oțel inoxidabil, recipient realizat din HDPE.
- Destinat lichidelor cu vâscozitate mica pana la medie, precum: uleiuri, oua lichide, jeleuri, sosuri, marinate.
- Pulverizarea uniforma a produsului - de la un strat foarte subtire la unul foarte gros.
- Debit reglabil al produsului.
- Piesele neelectrice pot fi curatate in masina de spalat vase, dupa dezasamblare.



- Recipientul este sigur pentru microunde - pana la 70°C.
- Inclus in set:
  - recipient cu insurubare cu capacitatea de 700 ml,
  - duza plata,
  - duza cu jet rotund,
  - extensie duza curbata

cod	V	W	mm	lei
270882	230	60	240x90x(H)220	2199,00

## PULVERIZATOR CU PRESIUNE PENTRU ALIMENTE HENDI

- Ideal pentru: ungerea formelor de copt, aplicarea aditivilor alimentari si aromelor, umezirea aluatului pentru paine.
- Pulverizarea unui strat perfect uniform a lichidului.
- Pulverizatorul sub presiune functioneaza in bucatarie fara a fi nevoie sa folositi aparate grele.
- Fabricat din polimer foarte durabil - HDPE.
- Partea inferioara lata a flaconului, asigura stabilitatea.
- Garnituri din silicon care nu necesita ungere.
- O duza reglabila care isi poate schimba pozitia la 360°.
- Conducta de aspiratie are un filtru pentru a preveni infundarea.
- O scala de masurare pentru un control usor al nivelului de lichid.
- O supapa de aerisire care protejeaza capacul.
- Presiune: 2,2 bari.
- Greutate: 0,59 kg.



270875

cod	mm	lei
270875	140x220x(H)330	129,99





640913

dimensiune plasa  
7,5 x 7,5 mm

**PALETA CARTOFI PRAJITI**

- Otel inoxidabil cu maner din poliamida (PA)
- Adanca

cod	mm	lei
640913	ø240x640	<b>99,99</b>
640920	ø260x650	<b>114,99</b>



640609

dimensiune  
plasa 5x5 mm

**PALETA CARTOFI PRAJITI**

- Cu maner armat din sarma

cod	mm	lei
640401	ø160x470	<b>43,99</b>
640500	ø180x470	<b>48,99</b>
640609	ø200x510	<b>54,99</b>
640708	ø220x540	<b>62,99</b>
640807	ø240x540	<b>75,99</b>



640203

dimensiune  
plasa 5x5 mm

**PALETA CARTOFI PRAJITI**

- Cu maner din sarma

cod	mm	lei
640104	ø100x310	<b>27,99</b>
640203	ø125x360	<b>37,99</b>

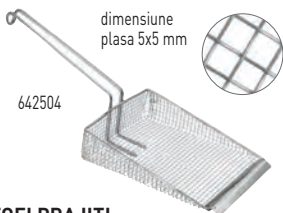

642504

dimensiune  
plasa 5x5 mm

**SCAFA CARTOFI PRAJITI**

- Cu maner sarma cu lungimea de 150 mm

cod	mm	lei
642504	470x180	<b>70,99</b>

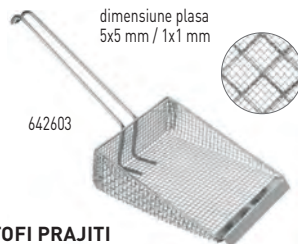

642603

dimensiune plasa  
5x5 mm / 1x1 mm

**SCAFA CARTOFI PRAJITI**

- Cu maner sarma cu lungimea de 225 mm
- Sita dubla

cod	mm	lei
642603	335x175	<b>83,99</b>



630006

**COLANDER CARTOFI PRAJITI - ALUMINIU**

- Baza fixa si strecuratoare detasabila

cod	mm	lei
630006	ø400x(H)170	<b>102,99</b>



630808

**COLANDER CARTOFI PRAJITI**

- Otel inoxidabil
- Cu maner din otel inoxidabil
- Cu baza detasabila

cod	mm	lei
630808	ø410x(H)170	<b>149,99</b>



Vezi filmul



630808



### SOLNITA PENTRU SARE SI PIPER

- Cu capac cu filet



cod		mm	lei
630235	Solnita piper	ø63x(H)100	18,99
630136	Solnita sare	ø80x(H)175	51,99



### SOLNITA PENTRU SARE SI PIPER

- Cu capac cu filet



cod		mm	lei
630204	Solnita piper	ø65x(H)105	21,99
630105	Solnita sare	ø80x(H)195	46,99



646304



### SEPARATOR GRASIME - PLASA FINA

- Cu maner din sarma

cod	mm	lei
646205	ø125x350	36,99
646304	ø150x440	34,99



646601



### STRECUATOARE "CUIB DE PASARE"

- Cu maner din sarma si clip de fixare

cod	mm	lei
646601	ø100x390	44,99



Vezi filmul



642559



### PLANIE DE CARTOFI PRAJITI SI NACHOS

- Cu maner detasabil
- Deschidere 80 mm
- Atat pentru stangaci cat si pentru dreptaci

cod	mm	lei
642559	230x220	49,99



642566



### PLANIE DE CARTOFI PRAJITI SI NACHOS

- Deschidere 75 mm
- Atat pentru stangaci cat si pentru dreptaci

cod	mm	lei
642566	233x205	34,49





632901



### SUPPORT FILTRU DE GRASIME PENTRU FRITEUZE

cod	mm	lei
632901	ø250x(H)240	69,99



Vezi filmul



632802

### FILTRU DE GRASIME PENTRU FRITEUZA - 50 BUC.

- Filtrele HENDI pentru grasime sunt esentiale in gastronomia profesionala - extind durata de utilizare a uleiului
- Concepute din matase sintetica, clasificata ca fibra sintetica, fabricata din ingrediente naturale
- Filtrele HENDI pentru grasime sunt extrem de rezistente. Rezistenta termica pana la 200°C
- Pe langa proprietatile de filtrare, filtrele pentru grasime prelungesc si durata de viata a friteuzelor
- Filtrele HENDI pentru grasime dispun de certificat de conformitate

cod	ambalat pe	mm	lei
632802	50	254x254	69,99

Prelungeste durata  
de utilizare a uleiului

196007

### GALEATA

- Adecvat pentru depozitarea uleiului pentru prajire si a sosurilor.
- Fabricat din polipropilena alba.
- Rezistenta ridicata la caldura - poate fi umplut cu lichide la temperaturi intre 85-95°C
- Capac din polipropilena (inclus)

cod	litri	mm	lei
196007	11.5	ø300x(H)230	20,99



518700



### PALNIE

cod	mm	lei
518700	ø128x(H)115	22,99



567616



### PALNIE

cod	mm	lei
567616	ø100x(H)115	6,99
567630	ø130x(H)117	9,99
567654	ø150x(H)140	10,99



516713

**S.S.**  
stainless steel**CAPAC PENTRU GALEATA CU BAZA CONSOLIDATA**

cod	-	mm	lei
516690	516683	ø280x(H)15	59,99
516713	516706	ø290x(H)15	67,99
516737	516720	ø305x(H)15	59,99

**S.S.**  
stainless steelBaza larga,  
consolidata  
pentru stabilitate  
si igiena

516720

**GALEATA CU BAZA CONSOLIDATA**

- Gradata

cod	litri	mm	lei
516676	7	ø230x(H)245	149,99
516683	10	ø280x(H)265	159,99
516706	12	ø300x(H)310	179,99
516720	15	ø305x(H)330	209,99

**S.S.**  
stainless steel

516744

**GALEATA**

- Fabricat din oțel inoxidabil
- Forma marginii asigură un control ușor al lichidului în timpul turnării

cod	litri	mm	lei
516744	12	ø310x(H)300	119,99

**S.S.**  
stainless steel**GALEATA**

- Fabricat din oțel inoxidabil. Forma marginii asigură un control ușor asupra lichidului în timpul turnării.

cod	litri	mm	lei
516768	10	ø278x(H)235	60,99



516768



222560

**PA**  
poliamidă**PP**  
polipropilenă

Vezi filmul

**USCATOR SALATA**

- Ideal pentru uscarea unei cantități mari de legume și fructe după spălare
- Cu un sistem de drenare a apei ușor de utilizat
- Cos interior detașabil

cod	litri	mm	lei
222553	12	ø335x(H)430	427,99
222560	25	ø430x(H)530	571,99

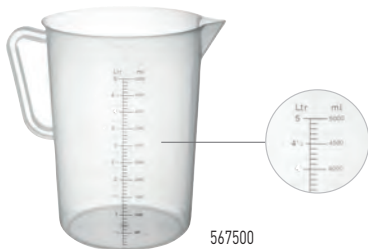

567500

**CANA GRADATA DIN POLIPROPILENA**

- Gradata



cod	litri	mm	lei
567104	0.5	ø90x(H)140	<b>7,99</b>
567203	1	ø110x(H)170	<b>19,99</b>
567302	2	ø140x(H)215	<b>24,49</b>
567401	3	ø160x(H)240	<b>29,99</b>
567500	5	ø190x(H)270	<b>44,99</b>



Poate fi stivuit

567852

**CANA DE MASURARE STIVUIBILA**

- Scala in relief in partea laterala a vasului.

- Forma manerului permite stivuirea mai multor cani.



cod	litri	mm	lei
567814	0.5	ø95x(H)136	<b>11,99</b>
567821	1	ø124x(H)170	<b>15,99</b>
567838	2	ø160x(H)205	<b>20,99</b>
567845	3	ø181x(H)233	<b>25,99</b>
567852	5	ø210x(H)270	<b>35,99</b>



516300

**CANA GRADATA DIN OTEL INOXIDABIL**

- Constructie solida



cod	litri	mm	lei
516102	0.5	ø90x(H)105	<b>63,99</b>
516201	1	ø120x(H)130	<b>86,99</b>
516300	2	ø140x(H)170	<b>119,99</b>



562079

**SCAFA**

cod	litri	mm	lei
562000	0.125	(L)187	<b>11,99</b>
562017	0.25	(L)250	<b>14,99</b>
562079	0.65	(L)330	<b>22,99</b>



521502

**SCAFA DIN ALUMINIU**

cod	litri	mm	lei
521205	0.125	(L)180	<b>15,99</b>
521304	0.2	(L)205	<b>17,99</b>
521403	0.3	(L)245	<b>20,99</b>
521502	0.5	(L)265	<b>27,99</b>
521601	0.65	(L)310	<b>35,99</b>
521809	2	(L)390	<b>69,99</b>

## FIERBATOARE ELECTRICE

- Carcasa si elementul de incalzire din otel inoxidabil
- Maner, capac si baza din polipropilena
- Element de incalzire, protejat impotriva depunerii de calcar, fapt ce prelungeste durata de viata a incalzitoului si a intregului fierbator



209981



Vezi filmul

Indicator pentru nivelul apei externe



- Indicator luminos ce arata faptul ca incalzitoul este pornit
- Oprire automata dupa fierbere
- Protectie dubla la fierbere uscata
- Potrivit doar pentru fierbere apa, fierberea altui lichid va deteriora produsul



209936



## FIERBATOR ELECTRIC - 1.8 LT

cod	litri	V	W	mm	lei
209981	1.8	230	2150	226x165x(H)310	94,99

## FIERBATOR ELECTRIC - 2.5 LT

cod	litri	V	W	mm	lei
209936	2.5	230	2150	242x172x(H)294	104,99



209998



Vezi filmul

Indicator interior pentru nivelul maxim al apei



Panou de comanda cu afisaj digital



209943



## FIERBATOR ELECTRIC - 4.2 LT

cod	litri	V	W	mm	lei
209998	4.2	230	2000	341x226x(H)305	159,99



624302



## CEAINIC - CU CAPAC

cod	litri	mm	lei
624302	6	ø245x(H)290	149,99

## FIERBATOR ELECTRIC FARA FIR CU CONTROL AL TEMPERATURII

- Pentru prepararea bauturilor cu conditii de preparare indicate, cum ar fi ceaiul verde, ceaiul alb sau yerba mate.
- Carcasa si incalzit din otel inoxidabil AISI304.
- Maner, capac si baza din polipropilena.
- Reglarea si mentinerea temperaturii - apa poate fi incalzita la una dintre aceste temperaturi: 40°C, 60°C, 80°C, 100°C.
- Element de incalzire plasat sub stratul de otel din interior, protejat impotriva calcarului, protejat impotriva calcarului.
- Panou de control cu afisaj digital.
- Indicator luminos al termostatului.
- Indicator intern de nivel maxim al apei.
- Functie de oprire automata dupa ce apa a fiert.
- Protectie dubla impotriva pornirii fierbatorului fara lichid in interior.
- Ceainic care poate fi rotit - baza de 360°.
- ATENTIE: destinat numai pentru fierberea apei, fierberea altor lichide poate deteriora ceainicul.

cod	litri	V	W	mm	lei
209943	1.8	230	1800	230x165x(H)255	144,99



Vezi filmul



18/0

stainless steel

680025

### PENSETA UNIVERSALA

cod	mm	lei
680049	(L)160	14,99
680032	(L)215	13,99
680025	(L)230	20,99
680018	(L)300	23,99



18/0

stainless steel

680186

### PENSETA CURBATA

cod	mm	lei
680186	(L)240	24,99



18/0

stainless steel

680063

### PENSETA - CURBATA

cod	mm	lei
680070	(L)160	15,99
680063	(L)240	15,99
680056	(L)305	24,99



18/0

stainless steel

680162

### PENSETA CU VARF ROTUND

cod	mm	lei
680162	(L)145	14,99



680087

### PENSETA - SUSHI

cod	mm	lei
680087	(L)210	15,99
680094	(L)160	14,99



680124

### PENSETA, CAP ROTUND

cod	mm	lei
680124	(L)150	14,99
680193	(L)305	22,99

18/0  
stainless steel



680155

### PENSETA DEZOSARE PESTE

cod	mm	lei
680155	(L)155	13,99



680131

### PENSETA UNIVERSALA NEAGRA

- Prin aplicarea cu PVD, acoperirea neagra.
- Calitate ridicata si durabila.

cod	mm	lei
680131	(L)300	32,99

18/0  
stainless steel



### PENSETA UNIVERSALA JB CU VARFURI ROTUNDE

- Confectionat din oțel inoxidabil 18/0
- Acoperire PVD neagra
- Inalta calitate si durabilitate
- Lungime: 30,5 cm
- NOTA: Nu este potrivit pentru spalarea in masina de spalat vase

cod	mm	lei
680216	(L)305	37,99

18/0  
stainless steel



680179

### PENSETA CU VARF ROTUND

cod	mm	lei
680179	(L)170	18,99



680117

### PENSETA - PESTE

cod	mm	lei
680117	(L)120	10,99
680100	(L)130	18,99

18/0  
stainless steel



680148

### PENSETA PENTRU OASE DE PESTE, CAP MIC PLAT

cod	mm	lei
680148	(L)100	10,99



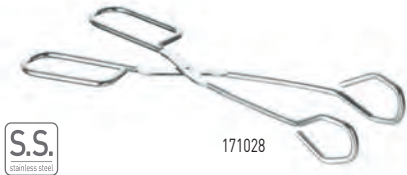

171028

**CLESTI DE SERVIRE - 2 BUC.**

cod	ambalat pe	mm	lei
171127	2	(L)300	38,99
171028	2	(L)240	32,99

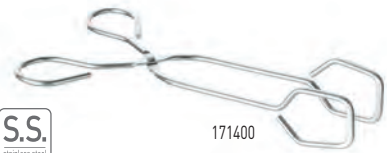

171400

**CLESTI SERVIRE**

cod	ambalat pe	lei
171509	1	13,99
171400	1	10,99



171318

**CLESTI SERVIRE**

- Cu silicon rezistent la caldura
- Cu blocare

cod	mm	lei
171301	(L)267	21,99
171318	(L)345	24,99
171325	(L)445	25,99



171349

**PENSETE DE BUCATARIE DIN SILICON**

- Oferă o prindere buna si este confortabil de utilizat
- Fabricata din silicon
- Rezistent la temperaturi de pana la 280°C, ceea ce o face ideala pentru utilizare la gatit

cod	mm	lei
171349	(L)290	36,99



524008

**CLESTE UNIVERSAL**

- Cu clip de fixare
- Detasabil



cod	mm	lei
524008	(L)270	29,99



Vezi filmul



### CLESTI DE SERVIRE HACCP 250 MM

- Pentru servicii alimentare profesionale - culori pentru piese de mana conforme HACCP
- Lungime: 250 mm

cod	culoare	mm	lei
171837	Rosu	(L)250	17,99
171929	Maro	(L)250	17,99
171844	Albastru	(L)250	17,99
171875	Verde	(L)250	17,99
171882	Mov	(L)250	17,99
171899	Galben	(L)250	17,99

### CLESTI DE SERVIRE HACCP 300 MM

- Pentru servicii alimentare profesionale - culori piesa de mana compatibile HACCP
- Lungime: 300 mm

cod	culoare	mm	lei
171721	Rosu	(L)300	19,99
171936	Maro	(L)300	19,99
171738	Albastru	(L)300	19,99
171745	Verde	(L)300	19,99
171783	Mov	(L)300	19,99
171790	Galben	(L)300	19,99



### CLESTE DE SERVIRE

- Maner acoperit cu PVC.

cod	culoare	mm	lei
171752	Negru	(L)250	12,99
171851	Negru	(L)300	17,99

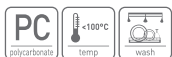

### CLESTE SERVIRE

cod	culoare	mm	lei
657621	Transparent	(L)230	12,99
657607	Negru	(L)230	12,99





171806



**DESIGN  
SOLID  
GROSIME  
MATERIAL  
1 MM**

**CLESTI SALATA**

- Cu clip de fixare
- Design solid



cod	mm	lei
171707	(L)240	12,99
171806	(L)310	14,99
171905	(L)400	17,99



525159



525142



658000

**SPATULA CURBATA DIN LEMN**

- Fabricat din lemn de fag - nu doar rezistent, ci si usor.
- Rezistent la temperaturi ridicate.

cod	ambalat pe	mm	lei
525159	2	(L)320	7,99

**SPATULA DE LEMN - SET DE 4 SPATULA**

- Lemn

cod	ambalat pe	mm	lei	cod	mm	lei
525142	4	(L)300	10,99	658000	(L)280	24,99

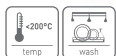

659502

**SPATULA**

- Cu fante
- Din plastic exoglass

cod	mm	lei
659502	(L)300	59,99

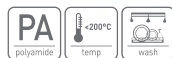

659601

**SPATULA**

cod	mm	lei
659601	(L)325	55,99



Vezi filmul

855713



### RAZAITOR

- Maner din plastic negru

cod	lungimea lamei (mm)	mm	lei
855713	124	102x265	<b>24,99</b>



855119



### RAZAITOR

- Cu maner din lemn

cod	lungimea lamei (mm)	mm	lei
855119	118	100x251	<b>22,99</b>



855508

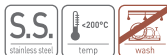

### SPATULA HAMBURGER

- Cu maner din lemn

cod	lungimea lamei (mm)	mm	lei
855508	120	75x270	<b>24,99</b>
855607	150	110x305	<b>29,99</b>



855676

### SPATULA HAMBURGER

- Maner din plastic negru

cod	lungimea lamei (mm)	mm	lei
855676	143	77x283	<b>35,99</b>
855652	174	108x313	<b>54,99</b>



855669

### PALETA FLEXIBILA

- Maner din plastic negru

- Flexibila

cod	grosime (mm)	mm	lei
855737	1	375x73	<b>38,99</b>
855669	1.2	320x96	<b>42,99</b>



855720



### PALETA FLEXIBILA, PERFORATA

- Maner din plastic negru

- Perforata

- Flexibila

cod	grosime (mm)	mm	lei
855720	1	375x75	<b>34,99</b>



520628

### SPATULA DE LEMN

- Pentru amestecarea unor cantitati mari de lichide si semi-lichide

- Spatula dintr-o singura bucata de lemn natural

- Exceptional de rezistente

cod	mm	lei
520604	700x95	<b>95,99</b>
520611	1000x95	<b>109,99</b>
520628	1250x95	<b>125,99</b>



525005



### LINGURA LEMN

- Fabricat din lemn.

- Set de 3 dimensiuni diferite.

- Mare: lingura 75x50 mm, lungime totala 400 mm.

- Mediu: lingura 65x50 mm, lungime totala 350 mm.

- Mic: lingura 60x45 mm, lungime totala 300 mm.

cod	mm	lei
525005	(L)475	<b>16,99</b>



- SPATULA**  
 - Maner din ABS  
 - Lama din cauciuc sintetic

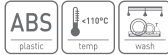

cod	lungimea lamei (mm)	mm	lei
659205	90	52x257	<b>13,99</b>
659304	116	70x358	<b>16,99</b>
659403	116	70x410	<b>24,99</b>



- SPATULA**  
 - Maner din PA  
 - Lama din silikon



cod	lungimea lamei (mm)	mm	lei
659014	90	55x266	<b>20,99</b>
659007	105	70x354	<b>33,99</b>
659106	105	70x420	<b>31,99</b>



- SPATULA**  
 - Maner din fibra de sticla armata cu naylon  
 - Lama din cauciuc natural  
 - Potrivita doar pentru produse reci



cod	lungimea lamei (mm)	mm	lei
658604	90	55x260	<b>24,99</b>
658703	90	75x320	<b>44,99</b>
658802	90	75x425	<b>49,99</b>
658901	150	100x515	<b>89,99</b>



**SPATULA IN FORMA DE LINGURA**

- Maner din ABS  
 - Lama din cauciuc sintetic

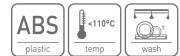

cod	lungimea lamei (mm)	mm	lei
659472	117	75x408	<b>26,99</b>
659458	88	57x254	<b>18,99</b>
659465	117	75x357	<b>27,99</b>



**LINGURA BUCATARIE PBT**



cod	mm	lei
563007	375x70	<b>25,99</b>
563106	450x80	<b>34,99</b>
563205	575x105	<b>50,99</b>



**LINGURA EXOGLASS**  
 - Fabricata din material Exoglass



cod	mm	lei
659700	(L)305	<b>44,99</b>
659809	(L)385	<b>59,99</b>

## LINGURI SI POLONICE SERIA PROFI LINE

- Profesionale, o singura bucata fara sudura,  
in conformitate cu standardele HACCP

- Otel inoxidabil dur  
- Grosime 2,7 mm

2.7 MM  
GROSIME



### POLONIC

- Cu margine anti-picurare

cod	litri	mm	lei
540107	0.06	ø60x360	25,99
540305	0.12	ø80x400	34,99
540404	0.25	ø100x430	41,49
540503	0.5	ø120x555	51,99
540602	0.75	ø145x575	61,99
540701	1	ø165x630	64,99

### SPUMIERA

cod	mm	lei
541104	ø80x390	30,99
541203	ø100x400	27,99
541302	ø120x460	42,99
541500	ø160x530	49,99

### LINGURA LEGUME

cod	mm	lei
542507	485x75	39,99

### FURCULITA FRIPTURA

cod	mm	lei
542705	(L)350	25,99

### LINGURA SOS

cod	mm	lei
542606	410x100	39,99

### SPATULA

cod	mm	lei
542200	510x100	50,99

## LINGURI SI POLONICE SERIA KITCHEN LINE



1.5 MM  
GROSIME



### POLONIC

cod	litri	mm	lei
527108	0.05	ø60x320	15,99
527207	0.17	ø90x390	18,99
527306	0.25	ø100x420	21,99

### SPUMIERA

cod	mm	lei
528105	ø90x310	16,99
528204	ø115x370	22,99

### SPATULA CU FANTE

cod	mm	lei
526118	(L)355	15,99

### SPATULA

cod	mm	lei
526101	(L)350	14,99

### FURCULITA FRIPTURA

cod	mm	lei
526200	350x35	13,99

### LINGURA LEGUME

cod	mm	lei
526309	(L)325	14,99

## TELURI



509470



Fire dure



510100



Fire dure



509203



Fire dure



Vezi filmul



1 MM  
GROSIME



2.2 MM  
GROSIME



2 MM  
GROSIME

### TEL PIANO

- 5 fire flexibile, cu maner subtire.
- Grosime sarma: 1 mm.

cod	mm	lei
509470	(L)285	9,99

### TEL FRENCH

- 8 fire rigide si groase, cu carlig
- Grosime fire: 2,2 mm

cod	mm	lei
510001	(L)290	20,99
510100	(L)335	21,99
510209	(L)380	22,99
510308	(L)435	28,99
510407	(L)490	29,99
511503	(L)540	30,99
511701	(L)640	35,99

### TEL FRENCH CU MANER PP

- 8 fire rigide si groase, cu carlig
- Grosime fire: 2 mm

cod	mm	lei
509005	(L)270	20,99
509104	(L)320	24,99
509203	(L)365	23,99
509302	(L)415	32,99
509401	(L)465	35,99



509487



Fire dure



### TEL SPIRALAT

cod	mm	lei
509487	(L)280	10,99



856109



Fire dure



### TEL

cod	mm	lei
856109	(L)300	35,99



532201

Fire extrem  
de flexibile  
pentru frisca



1.4 MM  
GROSIME

#### TEL PIANO

- 7 fire subtiri, flexibile, cu cartig
- Grosime fire: 1,4 mm

cod	mm	lei
532003	(L)230	<b>18,99</b>
532102	(L)275	<b>19,99</b>
532201	(L)330	<b>20,99</b>
532300	(L)375	<b>21,99</b>



Vezi filmul



511732

Fire extrem  
de flexibile  
pentru frisca



1.4 MM  
GROSIME

#### TEL PIANO

- 12 fire flexibile
- Maner din otel inoxidabil, cu cartig

cod	mm	lei
511718	(L)285	<b>17,99</b>
511725	(L)335	<b>20,99</b>
511732	(L)385	<b>21,99</b>
511749	(L)435	<b>23,99</b>
511756	(L)485	<b>27,99</b>



509449

Fire extrem  
de flexibile  
pentru frisca



1.4 MM  
GROSIME

#### TEL PIANO

- 12 fire subtiri, flexibile
- Maner polipropilena, cu cartig
- Grosime fire: 1,4 mm

cod	mm	lei
509418	(L)250	<b>22,99</b>
509425	(L)270	<b>24,99</b>
509432	(L)320	<b>26,99</b>
509449	(L)360	<b>29,99</b>
509456	(L)410	<b>34,99</b>
509463	(L)460	<b>39,99</b>





567562

**NOU****BOL DE AMESTECARE CU BAZA DIN SILICON**

- Bol realizat din oțel inoxidabil.
- Baza cu un strat de silicon anti-alunecare.
- Cu sistem de gradare în interiorul vasului.
- Poate fi spălat în mașina de spălat vase.

cod	mm	lei
567562	ø265x(H)125	79,99
567579	ø330x(H)155	99,99

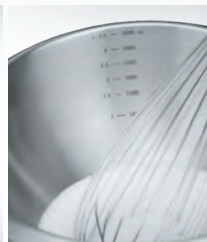

530702

**BOL BUCATARIE**

cod	litri	mm	lei
530108	0.7	ø160x(H)63	11,99
530207	1.2	ø205x(H)74	16,99
530306	1.5	ø227x(H)83	18,99
530405	2.6	ø254x(H)95	24,99
530504	3.3	ø281x(H)100	35,49
530603	4.4	ø310x(H)107	39,99
530702	5.7	ø340x(H)113	44,99



517604

**BOL AMESTECARE - CU BAZA ROTUNDA**

cod	litri	mm	lei
517109	0.7	ø158x(H)55	12,99
517208	1.4	ø197x(H)68	15,99
517307	2.3	ø240x(H)88	19,99
517406	3.3	ø259x(H)92	22,99
517604	4.9	ø300x(H)118	28,99

S.S.  
stainless steel

NOU



596487

596494

**CUPE DE MASURARE - SET DE 7 BUC.**

- Fabricat din otel inoxidabil.
- Baza plata pentru a asigura stabilitatea si a preveni rasturnarea.
- 2 fante pe fiecare cupa pentru o turnare usoara a continutului.
- Dotat cu manere ergonomice cu orificii.
- Gradatii gravate pe ambele parti.
- Masurare in sistem metric si american.
- 7 capacitati diferite incluse in set: 1/8 cana = 30 ml, 1/4 cana = 60 ml, 1/3 cana = 80 ml, 1/2 cana = 120 ml, 2/3 cana = 160 ml, 3/4 cana = 180 ml, 1 cana = 240 ml.
- Cupele pot fi stivuite - pentru a economisi spatiu de depozitare.
- Pot fi spalate in masina de spalat vase.

cod	mm	lei
596487	140x85x(H)52	80,99

**CUPE DE MASURARE - SET DE 4 BUC.**

- Fabricat din otel inoxidabil.
- Baza plata si o ureche suspendata pe fiecare ceasca pentru a asigura stabilitatea si a preveni rasturnarea.
- 2 orificii pe fiecare cupa pentru o turnare usoara a continutului.
- Dotat cu manere ergonomice cu orificii.
- Gradatii gravate pe ambele parti.
- Masurare in sistem metric si american.
- 4 capacitati diferite incluse in set: 1/8 cana = 30 ml, 1/3 cana = 80 ml, 1/2 cana = 120 ml, 3/4 cana = 180 ml.
- Cupele pot fi stivuite - pentru a economisi spatiu de depozitare.
- Pot fi spalate in masina de spalat vase.

cod	mm	lei
596494	135x80x(H)45	45,99

## PRESE SI ZDRIBITOARE

S.S.  
stainless steel



### ZDROBITOR CARTOFI

cod	mm	lei
693254	ø118x(H)310	<b>68,99</b>
693261	ø118x(H)455	<b>69,99</b>

### ZDROBITOR CARTOFI

cod	mm	lei
693001	130x85x(H)355	<b>89,99</b>
693100	180x85x(H)600	<b>98,99</b>
693209	180x85x(H)770	<b>119,99</b>

### ZDROBITOR CARTOFI

cod	mm	lei
693216	200x130x(H)610	<b>89,99</b>
693223	200x130x(H)810	<b>84,99</b>



PP polipropilene S.S. stainless steel

### ZDROBITOR DE CARTOFI

- Maner confortabil din polipropilena.

cod	mm	lei
856147	ø95x(H)230	<b>37,99</b>



S.S.  
stainless steel

### PRESA PENTRU CARTOFI

cod	mm	lei
515105	320x110	<b>149,99</b>



647516

dimensiune plasa  
0,5x0,5 mm



### SITA CONICA CU PLASA DE SARMA

- Plasa fina cu maner din sarma

cod	mm	lei
647516	ø160x360	39,99
647509	ø180x415	42,99



647554

dimensiune plasa  
0,5x0,5 mm



### SITA CONICA CU PLASA PE JUMATATE

- Plasa fina

cod	mm	lei
647554	ø205x460	89,99
647561	ø245x500	96,99



547304

dimensiune  
plasa: ø2 mm



### SITA CONICA

cod	mm	lei
547304	ø180x380	52,99
547502	ø235x435	81,99



567555



### SITA CONICA CU PLASA METALICA, INTARITA

- Fabricat integral din otel inoxidabil satinat AISI 201.

- Plasa foarte fina, intarita.
- Maner plat cu orificiu, ranforsat.
- Prevazut cu un maner de sustinere suplimentar.
- Margine orientata spre exterior
- Poate fi spalata in masina de spalat vase.

cod	mm	lei
567555	505x250x(H)200	139,99



556719

### PANZA STRECURARE

- 100% bumbac.
- Panza lavabila pana la 95°C.

cod	mm	lei
556719	700x700	49,99



Vezi filmul



515501

Echipat cu  
2 fire razuitoare  
in partea  
inferioara



### APARAT DE PASAT LEGUME

- Perfect pentru prepararea supelor crema si a sosurilor de rosii
- Include 2 discuri (ø140mm), preparare grosiera si preparare fina

cod	mm	lei
515501	400x215x(H)175	179,99



635605



dimensiune  
plasa 1x1 mm

### SITA

- Cu maner sarma

cod	mm	lei
635001	ø120x290	<b>9,99</b>
635155	ø160x340	<b>13,99</b>
635209	ø180x355	<b>15,99</b>
635308	ø200x365	<b>19,99</b>
635407	ø230x395	<b>21,99</b>
635605	ø250x420	<b>27,99</b>



639023



dimensiune plasa  
4x4 mm/1,5x1,5 mm

### SITA CU PLASA DUBLA

- Maner lemn

- Suport solid

cod	mm	lei
639009	ø260x580	<b>72,99</b>
639016	ø310x800	<b>104,99</b>
639023	ø360x850	<b>109,99</b>



638903



dimensiune  
plasa 0,5x0,5 mm

### SITA - PLASA FINA PROFI LINE

- Cu maner sarma

cod	mm	lei
638309	ø100x255	<b>18,99</b>
638507	ø145x340	<b>25,99</b>
638705	ø210x450	<b>28,99</b>
638903	ø230x455	<b>44,99</b>



637609



dimensiune  
plasa 1x1 mm

### SITA PROFI LINE

- Cu maner sarma

cod	mm	lei
637104	ø160x325	<b>19,99</b>
637203	ø185x350	<b>25,99</b>
637302	ø200x365	<b>29,99</b>
637401	ø220x385	<b>33,99</b>
637500	ø240x405	<b>39,99</b>
637609	ø260x425	<b>39,99</b>

## STRECURATOARE PROFI LINE



## STRECURATOARE PROFI LINE

- Cu baza si 2 manere nituite

cod	mm	lei
535523	ø415x(H)210	199,99
535516	ø365x(H)185	179,99
535509	ø325x(H)175	129,99



535516



535424



535301

## STRECURATOARE PERFORATA

- Cu baza si 2 manere



cod	mm	lei
535400	ø225x(H)90	32,99
535417	ø285x(H)100	39,99
535424	ø315x(H)120	49,99

## STRECURATOARE KITCHEN LINE

- Cu baza si 2 manere



cod	mm	lei
535103	ø240x(H)110	24,99
535202	ø280x(H)135	33,99
535301	ø340x(H)160	44,99

## COLANDER EXTENSIBIL PENTRU CHIUVEȚE

- Realizat integral din otel inoxidabil AISI 201.
- Manere extensibile, anti-alunecare - acoperite cu cauciuc.
- Picioarele de sprijin pentru a le pune direct in chiuveta.
- Pasa fina.
- Latime reglabila pana la max. chiuveța: 545 mm.
- Poate fi spalata in masina de spalat vase.



cod	mm	lei
535219	360x240x(H)115	149,99

535219



## CANTARE

**MODEL NOU**



580011

### CANTAR PENTRU BUCATARIE 3 KG

- Carcasa fabricata din plastic ABS si otel inoxidabil.
- Afisaj LED incorporat.
- Masurand pana la 3000 g.
- Citire in grame (g), kilograme (kg), mililetri (ml), uncii (oz) sau livre (lb).
- Functii disponibile pe panoul tactil: pornit/oprit, tare, schimbarea unitatii.
- Oprire automata si resetare (tara automata).
- Notificari privind supraincarcarea si nivelul scazut al bateriei.
- Putere: 3 baterii AAA de 1,5 V - incluse in set.

cod	mm	lei
580011	165x180x(H)31	<b>69,99</b>

**MODEL NOU**



580226

### CANTAR PENTRU BUCATARIE 5 KG

- Carcasa fabricata din otel inoxidabil.
- Afisaj LCD digital incorporat.
- Masurand pana la 5000 g.
- Citire in grame (g), kilograme (kg), uncii (oz) sau livre (lb).
- Oprire automata si resetare (tara automata).
- Notificari privind supraincarcarea si nivelul scazut al bateriei.
- Alimentare: 1 baterie cu litiu de 3V - inclusa in set.

cod	max. kg	mm	lei
580226	5	169x218x(H)13	<b>89,99</b>



580462



### CANTAR DIGITAL PENTRU GASTRONOMIE, DE PANA LA 200 KG

- Cantar din otel inoxidabil.
- Masurare precisa gratie tehnologiei avansate - de la 200 g la 200 kg (440 lb).
- Precizie: 10-50 g / 0,02-0,1 lb.
- Citire in kg sau lb.
- Functia Tare.
- Operarea prin intermediul afisajului digital separat cu 4 butoane.
- Afisaj LCD cu consum redus de energie cu indicator de incarcare a bateriei.
- Acoperire rezistenta la amprente.
- Sursa de alimentare: 2 baterii AAA (incluse).
- Port USB-C - kitul include cablu.
- NOTA: Adaptorul de putere nu este inclus.

cod	max. kg	mm	lei
580462	200	298x248x(H)37	<b>399,99</b>



BATERIE REINCARCABILA

**MODEL NOU**

**ABS**  
plastic

**S.S.**  
stainless steel



Vezi filmul

**18/8**  
stainless steel



580028

### CANTAR DE BUCATARIE 10 KG

- Carcasa impermeabila din ABS si otel inoxidabil.
- Afisaj LED incorporat.
- Masurand pana la 10 000 g.
- Citire in grame (g), kilograme (kg), mililitri (ml), uncii (oz) sau livre (lb).
- Functii disponibile pe panoul tactil: pornit/oprit, tare, schimbarea unitatii.
- Opreire automata si resetare (tara automata).
- Notificari privind supraincarcarea si nivelul scazut al bateriei.
- Alimentare: baterie reincarcabila cu litiu incorporata.
- Cablu USB pentru reincarcare inclus in set.
- Rata de rezistenta la apa si la praf: IP67.

cod	mm	lei
580028	160x210x(H)19	<b>92,99</b>



580233

### CANTAR DE BUCATARIE 15 KG

- Cantareste pana la 15.000g cu o gradare de  $\approx$  1g cu un minim de 2g
- Suprafata fara sudura din otel inoxidabil, carcasa din plastic HIPS cu afisaj integrat
- Senzor de tensiune de inalta precizie pentru masuratori exacte
- Afisare in grame
- Touch control cu butoane on-off si tare
- Cu tara auto, supraincarcare si indicatie redusa
- Opreire automata, alimentata de 3 baterii AAA (nu sunt incluse)

cod	max. kg	mm	lei
580233	15	266x267x(H)34	<b>179,99</b>



# Termometre



	Termometru infrarosu	Termometru infrarosu cu sonda	Termometru rezistent la socuri, cu sonda	Termometru cu raspuns rapid
Cod	271148	271254	271407	271230
Unitate	°C / °F	°C / °F	°C / °F	°C / °F
Timp reactie	rapid	rapid	mediu	rapid
Temperatura min.	-32°C	-60°C	-50°C	-50°C
Temperatura max.	400°C	350°C	300°C	350°C
Acuratete	±1,5°C	±1,5°C	±1°C	±0,8°C
Gradatie	0,1°C	0,2°C	0,1°C	0,1°C
Mod blocare	✓	✓	✓	✓
Lungime sonda			213 mm	130 mm
Material sonda			otel inoxidabil	otel inoxidabil
Potrivit pentru folosire in cuptor				
Rezistent la apa			rezistent la stropire	✓
Oprire automata	✓	✓	✓	✓
Baterii incluse	✓	✓	✓	✓
Informatii aditionale	Raport distanta masurare 12:1 Indicator laser pentru tinta precisa in vederea masurarii	Raport distanta masurare 8:1	Funcctie temperatura Min/Max Cu suport, include carcasa protectie	IP65 rezistenta la apa Cu capac pentru sonda





**Termometru cu sonda pliabila**

**Termometru digital cu sonda pliabila**

**Termometru de buzunar, cu sonda**

**Termometru rezistent la apa**

**Termometru/timer pentru gatire**

271308	271315	271209	271162	271162
°C / °F	°C / °F	°C / °F	°C / °F	°C / °F
mediu	şredni	mediu	mediu	lent
-50°C	-50°C	-40°C	-50°C	-50°C
300°C	300°C	200°C	300°C	250°C
±1°C	±1°C	±1°C	±1°C	±1°C
0,1°C	0,1°C	0,1°C	0,1°C	1°C
✓		✓	✓	✓
110 mm	115 mm	65 mm	120 mm	150 mm
otel inoxidabil	otel inoxidabil	otel inoxidabil	otel inoxidabil	otel inoxidabil

doar sonda

✓  
✓  
Functie temperatura Min/Max

✓  
Temperaturile maxime si minime sunt inregistrate in timpul masuratorilor

✓  
✓  
Cu capac pentru sonda

✓  
✓  
Masoara temperatura intr-o secunda  
Cu capac si maner ergonomic

✓  
✓  
Cu functie timer  
Cu setare alerta temperatura



	<b>Termometru de buzunar</b>	<b>Termometru friptura</b>	<b>Termometru cuptor</b>	<b>Termometru frigider</b>	<b>Termometru pentru frigider</b>	<b>Termometru pentru frigider</b>	<b>Termometru lapte</b>
Cod	271216	271339	271179	271186	271117	271124	271247
Unitate	°C	°C / °F	°C	°C	°C	°C	°C
Timp reactie	mediu	lent	lent	lent	lent	lent	lent
Temperatura min.	0°C		50°C	-50°C	-40°C	-50°C	-10°C
Temperatura max.	100°C		300°C	25°C	40°C	50°C	110°C
Gradatie	1°C		10°C	10°C	1°C	1°C	1°C
Lungime sonda	127 mm	50 mm					140 mm
Material sonda	otel inoxidabil	otel inoxidabil					otel inoxidabil
Potrivit pentru folosire in cuptor		✓	✓				
Informatii aditionale	Capac sonda cu clips.	Cu indicator "rare-me-dium-well done"	Cu cartig special si suport. Usor de citit.	Cu cartig special si suport. Usor de citit.	Cu cartig pentru agatare	Cu cartig pentru agatare	Cu clema pentru fixarea termometrului pe marginea recipientului cu lapte





Vezi filmul



271254

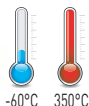

271148

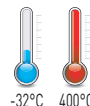

### TERMOMETRU INFRAROSU CU SONDA

- Scanarea temperaturii se poate face fie prin sonda pliabila, fie prin infrarosu
- Lampile de control HACCP ofera recunoasterea instantanee a temperaturilor sigure / nesigure.
- Cu sonda pliabila din otel inoxidabil cu o lungime de 90 mm.
- Domeniul de masurare -60 °C pana la 350 °C.
- Gradatie 0,2 °C.
- Precizia infrarosului: -60 / 65 °C ≈ 1 °C, 65/350 °C ≈ 1,5%.
- Precizia sondei: -60 / -5 °C ≈ 1 °C, -5 / 65 °C ≈ 0,5 °C, 65/350 °C ≈ 1%.
- Raportul la distanta (D: S) 8: 1.
- Oprire automata dupa 15 secunde.
- Baterie: 2xAAA (nu sunt incluse).

cod	gama	mm	lei
271254	-60/350°C	39x53x(H)158	<b>419,99</b>

### TERMOMETRU CU INFRAROSU

- Indicator laser pentru tinta precisa in vederea masurarii
- Interval de masurare: -32°C pana la 400°C
- Gradatie 0,1°C, acuratete ≈ 1,5°C / ≈ 1,5%
- Raport distanta masurare 12:1
- Mod blocare - pentru monitorizarea continua a temperaturii
- Se opreste automat
- Baterie inclusa

cod	gama	mm	lei
271148	-32/400°C	37x70x(H)150	<b>179,99</b>



271308

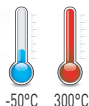

271209

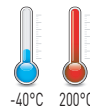

### TERMOMETRU CU SONDA PLIABILA

- Interval de masurare de la -50°C pana la 300°C
- Unitate masurare °C sau °F
- Gradatie 0,1°C, acuratete 1°C intre 0°C si 100°C
- Mod blocare - pentru monitorizare continua a temperaturii
- Functie temperatura min / max
- Sonda pliabila din otel inoxidabil, 110 mm
- Se inchide automat daca nu este folosit timp de o ora
- Baterie inclusa

cod	gama	mm	lei
271308	-50/300°C	160x40x(H)25	<b>79,99</b>

### TERMOMETRU DIGITAL CU SONDA - DE BUZUNAR

- Interval de masurare -40°C pana la 200°C
- Unitate masurare °C sau °F
- Gradatie 0,1 °C
- Acuratete ≈ 2° C
- Functie Hold - pastreaza temperatura de moment
- Sonda din otel inoxidabil 65 mm
- Se opreste automat
- Capac pentru sonda
- Baterie inclusa

cod	gama	mm	lei
271209	-40/200°C	150x20x(H)15	<b>49,99</b>



271407

### TERMOMETRU CU SONDA

- Interval de masurare de la -50°C pana la +300°C / -58°F pana la +572°F
- Unitate masurare °C sau °F
- Lizibilitate: 0,1° pentru -19,9° ~ +199,9°, altfel 1°
- Precizie: ≈1°C in intervalul -30°C ~ +250°C, altfel mai mult de ≈2°C
- Mod blocare - pentru monitorizare continua a temperaturii
- Functie min/max pentru temperatura
- Sonda detasabila din otel inoxidabil, 164 +/-3 mm
- Se opreste automat
- Carcasa de protectie si suport masa
- Alarma pentru temperatura setata
- Baterie inclusa

cod	gama	mm	lei
271407	-50/300°C	195x85x(H)45	259,99



271230

### TERMOMETRU CU RASPUNS RAPID

- Oferă citiri rapide și corecte ale temperaturii
- Rezistent la apa - IP65
- Interval de temperatura de la -50°C pana la 350°C, unitate de masura °C sau °F
- Gradatie 0,1°C, acuratete ≈0,8%/0,8°C
- Functie mentinere - salveaza temperatura dintr-un anumit moment
- Sonda de 130 mm din otel inoxidabil
- Oprire automata
- Dispune de capac pentru sonda
- Baterie inclusa

cod	gama	mm	lei
271230	-50/350°C	204x42x(H)20	219,99



Vezi filmul

Ofera o citire rapida si precisa a temperaturii



271346

### TERMOMETRU PENTRU GATIRE CU TIMER

- Cu functie timer
- Interval temperatura de la -50°C pana la 250°C
- Unitate temperatura °C sau °F
- Gradatie 1°C
- Mod blocare - pentru monitorizarea continua a temperaturii
- Functie min/max pentru temperatura
- Setare alerta temperatura
- Cu sonda din otel inoxidabil, 150 mm, ce poate fi lasata in cuptor (rezistenta la temperaturi inalte)
- 1 X 1,5V Baterie alcalina AAA inclusa (neincarcabila)

cod	gama	mm	lei
271346	-50/250°C	65x70x(H)17	59,99



271162

### TERMOMETRU REZISTENT LA APA

- Rezistent la apa
- Interval de masurare -50 °C pana la 300 °C
- Gradatie 0,1°C intre -19,9°C si 199,9°C, pentru alte intervale de temperatura 1°C
- Acuratete 1°C intre -20°C si 100°C, pentru alte intervale de temperatura ≈ 2°C
- Mod blocare - pentru monitorizare continua a temperaturii
- Sonda din otel inoxidabil 120 mm
- Masoara temperatura intr-o secunda
- Cu capac si maner ergonomic
- Se inchide automat dupa 10 minute
- Baterie inclusa

cod	gama	mm	lei
271162	-50/300°C	290x48x(H)40	64,99

**NOU****S.S.**  
stainless steel

271315

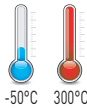
**TERMOMETRU DIGITAL CU SONDA PLIABILA**

- Sonda pliabila fabricata din otel inoxidabil AISI 304, lungime de 115 mm.
- Unitatea de temperatura poate fi setata la °C sau °F.
- Interval de temperatura: intre -50 °C si 300 °C.
- Precizia masurarii:
  - ≈1°C in intervalul -19,9°C - 119,9°C,
  - ≈2°C in intervalul de la -50°C la -20°C si de la 120 la 199,9°C,
  - ≈3°C in intervalul de la 200°C la 250°C,
  - ≈5°C in intervalul de la 250°C la 300°C.
- Rezolutie de citire: 0,1°C (rezultatul masurarii temperaturii este afisat cu o zecimala).
- Oprire automata dupa 45 de minute de inactivitate.
- Interval de temperatura ambienta de functionare: intre 0°C si 50°C.
- Temperaturile maxime si minime sunt inregistrate in timpul masurarilor.
- Alimentat cu 1x baterie AAA (este inclus).

cod	mm	lei
271315	160x55x(H)20	<b>69,99</b>

271339

**S.S.**  
stainless steel**TERMOMETRU PENTRU FRIPTURA - 4 BUCATI**

- Cu indicator rare-medium-well done
- Sonda otel inoxidabil de 50 mm
- Potrivit pentru folosire in cuptor

cod	ambalat pe	mm	lei
271339	4	ø25x(H)70	<b>40,99</b>

271216

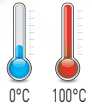
**TERMOMETRU DE BUZUNAR**

- Interval de masurare de la 0°C pana la +100°C
- Gradatie 1°C/33.8°F
- Sonda din otel inoxidabil 127 mm
- Capac sonda cu clema
- Usor de citit

cod	gama	mm	lei
271216	0/100°C	ø44.5x(H)140	<b>19,99</b>

271247

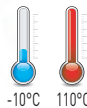
**TERMOMETRU LAPTE**

- Cu clema pentru fixarea termometrului pe marginea recipientului cu lapte
- Zona verde indica temperatura ideala a laptelui pentru cappuccino etc.
- Interval temperatura: de la -10°C pana la 110°C
- Gradatie: 1°C
- Sonda din otel inoxidabil cu capac protectie
- Usor de citit

cod	gama	mm	lei
271247	-10/110°C	ø44x(H)140	<b>25,99</b>





271261

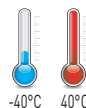
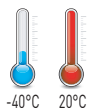

271117

### TERMOMETRU PENTRU FRIGIDER

- Model orizontal cu carlig pentru agatare
- Interval de temperatura de la -40°C pana la 20°C
- Gradatie 1°C

cod	gama	mm	lei
271261	-40/20°C	123x30x(H)19	15,99

### TERMOMETRU PENTRU FRIGIDER

- Cu carlig agatare
- Interval de temperatura de la -40°C pana la 40°C
- Gradatie 1°C

cod	gama	mm	lei
271117	-40/40°C	150x23x(H)9	9,99

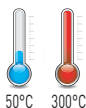

271179

### TERMOMETRU CUPTOR

- Interval de masurare de la 50 °C pana la 300 °C
- Gradatie 10°C
- Carcasa din otel inoxidabil cu carlig si suport
- Usor de citit

cod	gama	mm	lei
271179	50/300°C	60x40x(H)70	21,99

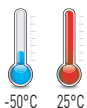

271186

### TERMOMETRU PENTRU FRIGIDER

- Interval de masurare de la -50°C pana la +25°C
- Gradatie 2,5°C
- Carcasa din otel inoxidabil cu suport si carlig
- Usor de citit

cod	gama	mm	lei
271186	-50/25°C	60x40x(H)70	19,99

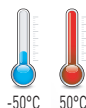

271124

### TERMOMETRU PENTRU FRIGIDER

- Cu carlig agatare
- Interval de temperatura de la -50°C pana la 50°C
- Gradatie 1°C
- Usor de citit

cod	gama	mm	lei
271124	-50/50°C	ø72x(H)21	14,99



design by Robert Bronwasser

NOU

### CEAS DE PERETE

- Concept de renumitul designer Olandez Robert Bronwasser
- Functioneaza cu 1 baterie AA de 1,5 V (neinclusa)

cod	mm	lei
271322	ø355x(H)45	69,99



271322

**NOU**ABS  
plastic

582039

**TEMPORIZATOR**

- Carcasa realizata din ABS, cu suport rabatabil, orificiu suspendat si magnet care atarna pe suprafete metalice.
- 3 moduri de alarma: silentios, moderat, puternic.
- Dupa ora setata:
  - o lumina rosie clipeste in fiecare mod,
  - in modurile moderat si puternic, alarma se stinge.
- Alarma luminoasa si sonora se opreste automat dupa 1 minut.
- Timp maxim setat: 100 min. cu precizie de 10 sec.
- 2 functii: numaratoare descrescatoare (99-0 min.), numaratoare crescatoare (0-99 min.).
- Alimentat cu 3 baterii AAA - nu este inclus.

cod	mm	lei
582039	82x20x(H)88	45,99

**NOU**ABS  
plastic

582046

**TEMPORIZATOR DUBLA**

- Carcasa realizata din ABS, cu suport rabatabil, orificiu suspendat si magnet pentru suprafete metalice.
- 3 moduri de alarma: silentios, moderat, zgomotos.
- Dupa trecerea timpului setat:
  - o lumina rosie clipeste in fiecare mod,
  - se activeaza si o alarma sonora in modul moderat si puternic.
- Alarma luminoasa si sonora se opreste automat dupa 1 minut.
- Posibilitatea de a seta 2 ori independente, cu dioda/alarma dezactivata dupa fiecare.
- Timp maxim setat: 100 min. cu precizie de 1 sec.
- 2 functii: numaratoare descrescatoare (99-0 min.), numaratoare crescatoare (0-99 min.).
- Functie de memorie: utilizatorul poate salva setarea pentru fiecare dintre cele 2 temporizatoare si o poate porni cu o singura apasare de buton.
- Alimentat cu 3 baterii AAA - nu sunt incluse.

cod	mm	lei
582046	82x20x(H)86	47,99



582015

**TIMER ANALOGIC BUCATARIE**

- Max. 60 minute
- Acuratete de 1 minut
- Spate magnetic
- Marcare cu rosu a timpului ramas
- Vizibil de la distanta

cod	mm	lei
582015	ø80x(H)30	45,99



582022

**TIMER DIGITAL BUCATARIE**

- Cu suport si magnet
- 99 min 59 s - numaratoare inversa

cod	mm	lei
582022	65x70x(H)17	49,99



Cu clips



Magnetica

ABS  
plastic**TIMER DIGITAL BUCATARIE**

- Cu clip magnetic.
- 99min59s - numaratoare inversa.
- 1 X 1,5V Baterie alcalina AAA inclusa (neincarcabila).

cod	mm	lei
271155	67x20x(H)67	28,99



Vezi filmul



512302

### INEL PENTRU DECORARE ROTUND

cod	mm	lei
512135	ø60x(H)45	<b>11,99</b>
512104	ø70x(H)45	<b>14,99</b>
512302	ø90x(H)45	<b>15,99</b>



512159

### INEL ROTUND

cod	-	mm	lei
512142	inel	ø80x(H)45	<b>16,99</b>
512159	inel	ø100x(H)45	<b>16,99</b>
512203	presa	ø80x(H)55	<b>9,39</b>
512210	presa	ø100x(H)55	<b>14,99</b>



512173

### INEL SI PRESA DECORARE - PATRAT

cod	-	mm	lei
512166	inel	65x65x(H)45	<b>17,99</b>
512173	inel	80x80x(H)45	<b>20,99</b>
512227	presa	63x63x(H)55	<b>10,99</b>
512234	presa	80x80x(H)55	<b>11,59</b>



Vezi filmul





551813

18/8  
stainless steel

Cu trei duze diferite  
(4, 5 si 6 mm)



### PALNIE PENTRU COFETARIE KITCHEN LINE

- Cu maner ergonomic, designul supapei asigura o etansare buna
- Cu 3 duze diferite (Ø 4, 5 si 6 mm)
- Ideala pentru dozare sosuri de diferite consistente si decorare
- Cu suport din sarma

cod	litri	mm	lei
551813	1.5	270x195x(H)270	209,99



551806

Cu trei duze diferite (4, 5 si 6 mm)

ABS plastic S.S. stainless steel

### PALNIE PENTRU COFETARIE PROFI LINE

- Maner ergonomic din ABS
- Designul supapei asigura o etansare buna
- Cu 3 duze diferite (Ø 4, 5 si 6 mm)
- Suport din sarma si vas de scurgere
- Creata pentru dozare sosuri de diferite consistente si decorare feluri de mancare si produse de cofetarie

cod	litri	mm	lei
551806	1.5	ø212x(H)315	259,99



Vezi filmul



## DYSPENSERY



558102



558119



558140

### RECIPIENT PENTRU SOS DIN OTEL INOXIDABIL CU DOZATOR

- Carcasa, arc in dozator si sistem mecanic fabricat din otel inoxidabil AISI 304.
- Elementul inferior al dozatorului este fabricat din polipropilena.
- Detasabil: capac, pompa distribuitor.
- Capac prevazut cu 2 incuietori cu blocare.
- Portie de sos distribuita: 35 ml
- Nu poate fi spalat in masina de spalat vase.

cod	litri	mm	lei
558102	4.5	ø180x(H)420	1129,00

### SET: 2 X RECIPIENT PENTRU SOS DIN OTEL INOXIDABIL CU DOZATOR

- Carcasa, arc in dozator si sistem mecanic fabricat din otel inoxidabil AISI 304.
- Elementul inferior al dozatorului este fabricat din polipropilena.
- Detasabil: capac, pompa distribuitor.
- Fiecare capac este prevazut cu 2 incuietori cu blocare.
- Portie de sos distribuita: 35 ml
- Nu poate fi spalat in masina de spalat vase.
- Suport cu adaptor inclus in set.

cod	litri	mm	lei
558119	9	400x200x(H)440	2709,00

### CAPAC CU DOZATOR PENTRU RECIPIENTE GN

- Carcasa, arc in dozator si sistem mecanic fabricat din otel inoxidabil AISI 304.
- Elementul inferior al dozatorului este fabricat din polipropilena.
- Detasabil: capac, pompa distribuitor.
- Portia de sos distribuita: 35 ml.
- Nu poate fi spalat in masina de spalat vase.
- Potrivit pentru recipiente GN cu o inaltime de 200 mm (nu este inclusa).

cod	GN	mm	lei
558133	GN 1/6	180x165	875,99
558140	GN 1/4	270x165	929,99
558157	GN 1/3	330x180	999,99

### BAIN-MARIE PENTRU SOS CU DOZATOR

- Carcasa, arc in dozator si sistem mecanic fabricat din otel inoxidabil AISI 304.
- Elementul inferior al dozatorului este fabricat din polipropilena.
- Detasabil: capac, pompa distribuitor.
- Capac prevazut cu 2 incuietori cu blocare.
- Cu senzorul de protectie la supraincalzire - porneste alarma sonora si intrerupe automat incalzirea.
- Temperatura de incalzire reglabila: pana la 90°C.
- Portia de sos distribuita: 35 ml.
- Nu poate fi spalat in masina de spalat vase.

cod	litri	V	W	mm	lei
558126	3	230	900	ø180x(H)502	1929,00



<90 °C

558126

## STICLA DISPENSER

- Fabricat din polietilena.
- Capacul asigura igiena si prospektimea sosului.



Vezi filmul



558003

558010

558027



## STICLA DISPENSER

cod	ambalat pe	culoare	litri	mm	lei
558003	1	Galben	0.2	ø50x(H)185	<b>3,99</b>
558010	1	Rosu	0.2	ø50x(H)185	<b>3,99</b>
558027	1	Transparent	0.2	ø50x(H)185	<b>3,99</b>
557808	1	Galben	0.35	ø55x(H)205	<b>5,99</b>
557815	1	Rosu	0.35	ø55x(H)205	<b>5,99</b>
557822	1	Transparent	0.35	ø55x(H)205	<b>5,99</b>
557907	1	Galben	0.7	ø70x(H)240	<b>8,99</b>
557914	1	Rosu	0.7	ø70x(H)240	<b>8,99</b>
557921	1	Transparent	0.7	ø70x(H)240	<b>8,99</b>



557990



## MINI DOZATOR PENTRU SOS - SET DE 4 BUC.

- Fabricat din polietilena semitransparenta.
- Insurubati capacul cu un dop.
- Produs reutilizabil.
- Poate fi spalat in masina de spalat vase.

cod	litri	mm	lei
557990	0.05	ø35x(H)100	<b>35,99</b>
557891	0.03	ø30x(H)85	<b>35,99</b>



design by  
Robert Bronwasser



## STICLA DOZATOARE PENTRU SOS FARA PICURARE

- Pentru utilizare in baruri, bufete  
Vsi restaurante
- Proiectat de Robert Bronwasser
- Fabricat din polietilena
- Flacon transparent cu capac de dozare special conceput
- Designul sticlei va permite sa o puneti cu susul in jos fara riscul de scurgere a sosului
- Capacitate: 230 ml
- Potrivit pentru spalare in masina de spalat vase



558096

Varf  
anti-picurare

cod	litri	mm	lei
558096	0.23	ø50x(H)160	<b>7,99</b>



Distribuirea este foarte usoara datorita materialului flexibil

558386



## STICLA DISPENSER

- Designul recipientului si materialul flexibil din care este produs fac dozarea extrem de facila
- Dopul se inchide ermetic si asigura prospektime si igiena
- Orificiul mic asigura protectie la scurgere cand recipientul este tinut invers

cod	culoare	litri	mm	lei
558386	Transparent	0.3	ø65x(H)190	<b>5,99</b>



18/0  
STAINLESS STEEL

557969

### STAND SOS

- Finisare de calitate
- Cu 3 orificii
- Potrivit pentru sticlele dispenser HENDI

cod	-	mm	lei
557969	3 orificii ø 50 mm	209x80x(H)78	39,99
557976	3 orificii ø57 mm	229x90x(H)78	52,99
557983	3 orificii ø70 mm	274x102x(H)98	69,99



429457

429440

S.S.  
STAINLESS STEEL

### SUPORT TACO

cod	-	mm	lei
429440	Suport pentru taco	135x115x(H)50	34,99
429457	Suport pentru 4 taco	225x115x(H)50	39,99



203521

203538

203545



### DISPENSER CU POMPA

- Dispenser cu pompa de dozare pentru diferite tipuri de sosuri
- Pentru utilizare in snack-baruri, bufete, restaurante si catering
- Carcasa din ABS
- Recipient interior cu cana de masurare, capac si pompa detasabila din polipropilena
- Materialul recipientelor este fara BPA
  - nu afecteaza gustul si mirosul continutului
- Blocarea pompei pentru a preveni actionarea accidentala in timpul transportului

- Dozaj: 20 ml
- Rezistenta termica: de la -40°C pana la +70°C
- Dezasamblare simpla si posibilitate de stivuire
- Potrivit pentru spalare in masina de spalat vase

cod	culoare	litri	mm	lei
203521	Rosu	2.5	230x210x(H)327	94,99
203545	Alb	2.5	230x210x(H)327	94,99
203538	Galben	2.5	230x210x(H)327	94,99





## INFUZOR FUM - 3 TREPTE DE PUTERE PENTRU AFUMARE

- Afumarea este o modalitate foarte buna de a adauga o aroma unica mancarurilor din carne, peste si legume
- Cu ajutorul fumului, puteti servi si felurile de mancare intr-un mod original, creand prezentari de efect
- Fumul rece este bland cu fructele si legumele delicate, nu le modifica textura si temperatura
- Camera ventilatorului din aluminiu actioneaza ca un radiator, racind fumul
- Operare cu un singur buton
- 3 trepte de putere
- Ventilatorul poate fi rotit si pentru a aspira aer
- Chipsurile de parfum nu trebuie sa fie inmuiate in prealabil inainte de afumare
- Puteti folosi si ceai sau condiment pentru afumare
- Camera de afumare cu filtru plasa integrat, detasabila pentru curatare usoara
- Furtun flexibil din silicon (50 cm lungime) pentru suflarea usoara a fumului in pungi si recipiente resigilabile
- Usor, cu un maner confortabil pentru o operare facila cu o singura mana
- Alimentat de o baterie cu litiu de 1000 mAh
- Furnizat intr-un set cu filtre cu plasa de rezerva, penseta si cablu de incarcare USB
- Chipsurile de parfum sau ierburile pentru fumat nu sunt incluse

cod	mm	lei
199640	215x70x(H)160	369,99



199640



Al  
aluminium



199992



### INFUZOR FUM

- Pentru gastronomie profesionala
- Poate fi folosit pentru fructe si legume moi - fumul nu va influenta textura
- Radiator cu corp din aluminiu pentru a raci fumul
- Camera de ardere detasabila cu filtru incorporat
- Furtun flexibil din cauciuc (30 cm lungime) pentru distribuirea usoara a fumului in pungi si containere inchise cu sfoara

- Chipsurile de afumare nu necesita pre-inmuiere inainte de utilizare
- Poate fi folosit si pentru afumarea ceaiului sau a condimentelor
- Compact si usor - usor de utilizat cu o singura mana
- Alimentare: 2 baterii AA (nu sunt incluse)
- Chipsurile pentru afumare nu sunt incluse

cod	mm	lei
199992	90x54x(H)122	94,99



orificiu de infuzare

199664

199657

### CLOCHE DIN STICLA CU ORIFICII

- Fabricat din sticla borosilicata, cu orificiu de ventilare din silicon pentru furtunul infuzorului de fum.
- Se recomandata utilizarea impreuna cu infuzorul de fum, creaza un mod spectaculos de prezentare a preparatelor.

cod		mm	lei
199664	Cloche sticla cu gaura pentru infuzor fum	ø260x(H)174	349,99
199657	Cloche din sticla cu gaura pentru furtun fum	ø130x(H)282	149,99



199978

### CLOCHE DIN STICLA

- Ideal pentru a fi utilizat in combinatie cu infuzorul de fum, creati o modalitate spectaculoasa de a preenta clientilor diverse tipuri de preparate.

cod	mm	lei
199978	ø275x(H)140	99,99



198124

### BRICHETA - 2 BUCATI

- Reincarabila
- Bricheta se distribuie neincarcata

cod	ambalat pe	mm	lei
198124	2	(L)230	36,99



## CHIPSURI PENTRU AFUMARE

Rumegusul și aschiile pentru afumare sunt obținute din lemnul nobil al unor specii de lemn de esență tare, lemn provenit, de asemenea, și de la pomi fructiferi, dar și din lemnul utilizat pentru butoaiile de maturare a vinului roșu, whiskey-ului și a cognac-ului.

Acestea din urmă sunt recomandate în special cunoscătorilor și împătimitilor băuturilor menționate mai sus, deoarece oferă o experiență gustativă unică. Chipsurile și rumegusul fin pentru afumare provin din

fragmente ale butoaielor vechi de stejar, în care au fost maturate băuturi spirtoase pe o perioadă de mai mulți ani.

În oferta noastră veți găsi rumegus fin pentru afumare și două tipuri de aschii de lemn – mici sau mari.

Utilizați-le în procesul de afumare și nu numai că veți obține gustul și aroma perfectă pentru orice tip de preparat, dar veți utiliza și o metodă de prezentare atractivă a acestora.



rumegus fin  
pentru afumare

pentru utilizare împreună  
cu o afumătoare sau un pistol  
pentru afumare

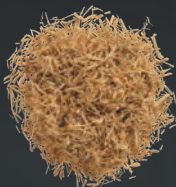

aschii de lemn mici,  
pentru afumare

pentru utilizare direct pe gratar  
sau împreună cu o afumătoare



aschii  
de lemn



STEJAR



FAG







CITRICE



PIERSICA



MIGDAL

rumegus fin pentru afumare		cod	199787	199183	199213	199237	199220
		greutate	450 g	450 g	450 g	450 g	450 g
		lei	29,99	29,99	29,99	29,99	29,99
aschii de lemn mici, pentru afumare		cod	199282	199275	199305	199329	199312
		greutate	700 g	700 g	700 g	700 g	700 g
		lei	32,99	32,99	32,99	32,99	32,99
aschii de lemn		cod	199374	199367	199398	199411	199404
		greutate	3 kg	3 kg	3 kg	3 kg	3 kg
		lei	32,99	32,99	32,99	32,99	32,99
bucati lemn		cod	199466	199459	199480	199503	199497
		greutate	3 kg	3 kg	3 kg	3 kg	3 kg
		lei	100,99	100,99	100,99	100,99	100,99

## BUCATI MARI

- Destinate utilizării la temperaturi medii și mari.
- Ideal pentru cuptoare de pizza, cuptoare de exterior și gratare - plasare direct pe carbunele încins.
- Aroma unică
- Amplificăți gustul preparatelor dvs.
- Fabricat din lemn natural de cea mai bună calitate sau din lemnul provenit de la butoaie de maturare. Oferta noastră include aschii realizate din lemn provenit de a butoaie în care s-a maturat vin, whisky sau coniac. - lemn de fag, maslin, citrice, migdal sau lemn de piersic



MASLIN



VIN ROSU



WHISKEY



COGNAC

	199190	199244	199251	199268
cod	199190	199244	199251	199268
greutate	450 g	450 g	450 g	450 g
lei	29,99	29,99	29,99	29,99

	199299	199336	199343	199350
cod	199299	199336	199343	199350
greutate	700 g	700 g	700 g	700 g
lei	32,99	32,99	32,99	32,99

	199381	199428	199435	199442
cod	199381	199428	199435	199442
greutate	3 kg	3 kg	3 kg	3 kg
lei	32,99	32,99	32,99	32,99

	199473	199510	199527	199534
cod	199473	199510	199527	199534
greutate	3 kg	3 kg	3 kg	3 kg
lei	100,99	100,99	100,99	100,99



199794

### SET RUMEGUS FIN PENTRU AFUMARE - 9 AROME

- Pentru afumare la rece - pistol pentru afumat sau afumatori clasice.
- Set de 9 tipuri diferite de rumegus fin.
- Arome din acest set: migdal, fag, citrice, coniac, stejar, maslin, piersic, vin rosu și whisky.

cod	greutate (kg)	lei
199794	1.35	207,99



238486



Vezi filmul



### AFUMATOARE ELECTRICA

- Cuptorul cu fum este ideal pentru a afuma o varietate de alimente, cum ar fi peste, carne de vita, sunca si legume.
- Fabricat din otel inoxidabil, cu o usa dubla izolata cu inchidere magnetica
- Temperatura reglabila cu un termostat, termometru integrat in usa
- Echipat cu un orificiu de aer cald in spate
- Livrat cu 3 grile (400x279mm) si 3 carlige pentru carne

cod	V	W	mm	lei
238486	230	1600	540x380x(H)725	1499,00



Vezi filmul



225479



### CUPTOR TEMPERATURA JOASA

- Proiectat pentru preparare lenta sau regenerare produse, printr-un proces foarte bine stabilit si controlat
- Termometru sonda reglabil incorporat
- Manere ingropate pe laturi
- Garnitura usii se curata usor
- Camera cuptorului este incalzita pe 4 laturi, distribuie uniform caldura in camera interioara
- Foarte eficient din punct de vedere al energiei datorita izolarii suplimentare
- Camera cuptorului fara sudura, cu colturi rotunjite, usor de curatat

- Temperatura reglabila prin trepte de cate 1 grad, camera cuptorului ajunge pana la 120 °C, temperatura din interior, si se pastreaza la 100 °C
- Usile sunt cu balamale stanga sau dreapta, usor de schimbat dintr-o parte in alta
- Setare digitala, citirea timpului si a temperaturii setate dar si a temperaturii sondei / temperaturii camerei
- Vas din otel inoxidabil si suport tava, potrivite pentru containere GN 1/1, gratare si tavi, de asemenea si pentru tavi patiserie 600x400 mm, pe 3 nivele

cod	V	W	mm	lei
225479	230	1200	495x690x(H)413	5199,00



199541

### CARBUNE MARABU

- Destinat utilizării în unități profesionale de catering.
- Pentru prepararea la gratar a carniilor, pestelui, fructelor de mare, legumelor și aperitivelor.
- Produs prin carbonizarea lemnului de esență tare la temperaturi cuprinse între 400 și 700°C, fără aer.
- Realizat din planta invazivă de marabou, care crește în Cuba - materie primă procurată responsabil, pentru producție ecologică. 100% natural.
- Fumul provenit din arderea acestui tip de lemn oferă mâncării o aromă unică.
- Putere calorică mare, nivel scăzut de scantei.
- Timp de ardere dublu, în comparație cu tipurile de carbune moale utilizate în mod obișnuit.

cod	kg	lei
199541	10	143,99





## APARAT FRISCA SI ACCESORII



Vezi filmul



Vezi filmul



## APARAT FRISCA PROFI LINE

- Produce frisca delicioasa, spume, deserturi, spume reci si sosuri
- Perfect pentru decorare cappuccino, cafea, shake-uri si inghetata
- Adecvat pentru dozare creme si sosuri calde de pana la 70 °C
- Pastreaza continutul proaspat pentru pana la 14 zile, in frigider
- Include 3 duze otel inoxidabil si o perie de curatat
- Necesita incarcator (N<sub>2</sub>O) pentru a functiona, nu este inclus

cod	litri	mm	lei
588017	0.5	ø85x(H)235	279,99
588024	1	ø98x(H)330	299,99



## APARAT FRISCA KITCHEN LINE

- Capac din aluminiu, recipient din aluminiu vopsit in alb si suport cartus
- Set de 3 duze din polipropilena si o perie de curatat
- Nu este adecvat pentru sosuri fierbinti
- Necesita incarcator (N<sub>2</sub>O) pentru a functiona, nu este inclus

cod	litri	mm	lei
588031	0.25	ø80x(H)200	124,99
588369	0.5	ø80x(H)260	139,99
588376	0.95	ø95x(H)320	149,99



**NOU**

588420

588598



### APARAT FRISCA KITCHEN LINE NEGRU

- Recipient din aluminiu acoperit cu negru mat, suport pentru incarcator si capac
- Set de 3 duze din polipropilena si o perie de curatare
- Nu este adecvat pentru sosuri fierbinti
- Necesita incarcator (N<sub>2</sub>O) pentru a functiona, nu este inclus

cod	litri	mm	lei
588420	0.5	ø80x(H)260	134,99
588598	0.95	ø95x(H)320	221,95 <b>NOU</b>

### SET PIESE DE SCHIMB

589205

cod		mm	lei
589205	Profi Line	120x30x(H)240	85,99



### SET PIESE DE SCHIMB

589007

cod		mm	lei
589007	Kitchen Line	120x30x(H)240	59,99



**S.S.**  
Stainless steel

pentru crema

pentru lichid

pentru decorare

### SET DUZE DECORARE

- Ideal pentru decorare, umplere, etc.
- Set de 4 duze din otel inoxidabil:
  - 1 duza lunga ø3 mm
  - 1 duza lunga ø5 mm
  - 1 duza scurta ø3 mm
  - 1 duza scurta ø5 mm

- Doar pentru folosire cu aparat frisca Profi Line

cod		lei
589106		69,99



975855

975893

975886

975879

975862



### APARAT FRISCA

- Constructie din aluminiu
- Set de 3 duze si o perie curatare
- Nu este potrivit pentru sosuri fierbinti
- Este necesar cartus (N<sub>2</sub>O), nu este inclus

cod	culoare	litri	mm	lei
975855	Galben	0.5	ø80x(H)260	139,99
975893	Turcoaz	0.5	ø80x(H)260	139,99
975886	Mov	0.5	ø80x(H)260	139,99
975879	Verde	0.5	ø80x(H)260	139,99
975862	Albastru	0.5	ø80x(H)260	139,99



Vezi filmul





588208

UNIVERSALE  
- PENTRU TOATE  
APARATELE  
DE FRISCA



588215



586907

### CARTUSE PENTRU APARAT FRISCA

- Universal pentru Liss, Kidde, Kaiser, ISI, etc
- N<sub>2</sub>O
- Termen de valabilitate 5 ani de la data fabricatiei

cod	ambalat pe	lei
588208	10	15,99
588215	24	39,99
586907	50	84,99





290965

304  
stainless steel**APARAT PENTRU FRISCA**

- Carcasa, recipient pentru frisca si elemente interne fabricate din otel inoxidabil durabil AISI 304.
- Recipient pentru crema usor de indepartat pentru o curatare usoara.
- Echipat cu un panou de comanda intuitiv.
- Functie de pre-racire pentru a mentine crema proaspata pentru mai mult timp.
- Distribuire manuala sau portionare automata in 3 dimensiuni de portie: mica, medie, mare.
- Nivelul de aerare al creimei reglabil cu un buton rotativ - asigurand consistenta optima a produsului finit
- Programul de curatare automata reduce semnificativ timpul de curatare.
- Agent frigorific: R600A ecologic.
- Capacitate de productie: 17 l/h.
- Setul include: 2 duze din POM, 3 perii rotunde pentru spalarea zonelor greu accesibile (mici, medii, mari).

cod	V	W	mm	lei
290965	230	420	537x234x(H)461	9749,00



290934

S.S.  
stainless steel**APARAT FRISCA ELECTRONIC HENDI 2.5 L**

- Pentru cafelele, gelaterii, patiserii si restaurante
- Produce frisca la temperatura de 4°C, cu o textura adecvata
- Curatare usoara datorita componentelor detasabile, standarde inalte de igiena
- Racire cu aer
- Capacitate rezervor 2,5 lt
- Rezervor detasabil
- Productivitate: 50 kg/h
- Greutate 25 kg

cod	V	W	mm	lei
290934	230	500	400x230x(H)430	14999,00





274231



Vezi filmul



### APARAT INGHETATA

- Ideal pentru prepararea de inghetata, sorbet si iaurt inghetat in decurs de 90 de minute
- Recipient de inghetata 2 lt, din otel inoxidabil
- Compresor racit cu aer, cu interval de temperatura -10°C pana la -35°C
- Cu functie racire timp de doua ore pentru pastrarea consistentei inghetatei, dupa ce este preparata
- Nu este necesara racirea prealabila a ingredientelor
- Ecran digital mare, iluminat, ce afiseaza timpul de lucru, temperatura de inghet si miscarea mixerului
- Paleta de amestecare din polipropilena, usor de montat
- Capac transparent din policarbonat cu sistem de inchidere sigura Twist-Lock
- Ceasca si lingura pentru masurare incluse
- Agent de racire: R600a

cod	V	W	mm	lei
274231	230	180	285x340x(H)357	1839,00



### CANTAR INGHETATA CU LCD CU PORT RS232

- Carcasa fabricata din plastic ABS.
- Tava plata si suportul pentru inghetata sunt fabricate din otel inoxidabil AISI 430.
- Afisaj LCD din 6 cifre.
- Panou de comanda cu butoane functionale: setari, zero, tare, iluminare de fundal a ecranului.
- Dotat cu portul RS232 pentru conectarea unei case de marcat sau a unei imprimante de chitante.
- Balanta integrata.
- 4 picioare anti-alunecare.
- Scala formata din doua cifre:
  - pana la 3 kg: gradatie de 1 g,
  - pana la 6 kg: gradatie de 2 g.
- Interval de cantarire: de la 20 g la 6 kg.
- Suprafata de cantarire - recipient plat: 176x223 mm.
- Cu legislatia primara.
- Suport pentru inghetata - scala de recipient (cod: 755754), incarcator inclus in set.

cod	max. kg	mm	lei
755761	6	255x264x(H)244	1019,00



755761



755754



755754



755761

### SUPPORT PENTRU CONURI DE INGHETATA - TAVA PENTRU CANTAR

- Fabricat din otel inoxidabil AISI 430.
- 2 orificii:
  - de dimensiuni mai mici ø45 mm
  - de dimensiuni mai mari ø65 mm
- Poate fi spalata in masina de spalata vase.

cod	mm	lei
755754	230x120x(H)151	143,99



### LINGURA DOZATOARE INGHETATA PROFI LINE

cod	-	mm	lei
759233	1/24	ø51	132,99
759240	1/30	ø49	132,99
759257	1/36	ø46	132,99
759264	1/40	ø44	132,99



18/8  
stainless steel



### LINGURA DOZATOARE INGHETATA KITCHEN LINE

cod	-	mm	lei
572016	1/10	ø70	49,99
572313	1/20	ø56	49,99
572115	1/12	ø66	49,99
572214	1/16	ø59	49,99
572412	1/24	ø53	49,99
572511	1/30	ø50	49,99
572610	1/36	ø48	49,99
572719	1/40	ø44	49,99



S.S.  
stainless steel

**stöckel**

### LINGURA DOZATOARE INGHETATA STÖCKEL

cod	-	mm	lei
755006	1/4	ø100	219,99
755013	1/8	ø80	219,99
755020	1/10	ø70	219,99
755037	1/12	ø67	219,99
755044	1/16	ø59	219,99
755051	1/20	ø56	219,99
755068	1/24	ø51	219,99
755075	1/30	ø49	219,99
755082	1/36	ø47	219,99
755099	1/40	ø45	219,99
755105	1/50	ø43	219,99
755112	1/60	ø40	219,99
755143	1/100	ø30	219,99





**stöckel**

PA  
polyamide

S.S.  
stainless steel



**LINGURA DOZATOARE INGHETATA STÖCKEL**

- Maner fibra de sticla intarita cu nylon
- Identificare mai usoara a portiei

cod	-	mm	lei
755334	1/12	ø67	214,99
755341	1/16	ø59	214,99
755358	1/20	ø56	214,99
755365	1/24	ø51	214,99
755372	1/30	ø49	214,99
755389	1/36	ø47	214,99
755396	1/40	ø45	214,99

Identificare mai usoara a lingurii



**LINGURA DOZATOARE INGHETATA STÖCKEL - OVALA**

cod	-	mm	lei
755259	1/20	70x52	249,99
755273	1/30	62x43	249,99

S.S.  
stainless steel

**stöckel**



755181



802007



802014

**SPALATOR CUPE DE INGHETATA**

- Pentru spalarea rapida si usoara a cuvelor si a altor accesorii mici pentru inghetata
- Permite curatarea cu un consum redus de apa
- Foarte usor de utilizat si de curatat. Sistem de spalare integrat activat prin presiune, asigurand un consum redus de apa
- Protectia din cauciuc protejeaza marginea saibei si manerul cupei impotriva deteriorarii mecanice
- Spalator (modelul 755174) poate fi montata pe un perete, blat sau orice alta suprafata plana
- alimentare cu apa de 3/8", drenaj Ø 20 mm
- Fabricat din otel inoxidabil 18/10

cod	-	mm	lei
755181	Sistem de spalare pentru accesorii preparare inghetata	270x110x(H)115	1539,00
755174	Sistem de spalare care se poate monta pe perete	220x120x(H)90	1699,00

**SPALATOR CUPE DE INGHETATA**

- Pentru utilizarea in gelaterie, cafenele si restaurante
- Curatarea completa si rapida a cuvelor si a altor accesorii mici pentru inghetata
- Menținerea curateniei locului de munca cu un consum redus de apa
- Fabricat din otel inoxidabil AISI 304
- Utilizare convenabila. Usor de curatat
- Poate fi montat pe un perete si pe alte suprafete verticale cu ajutorul suportului: 802014
- 3/8 de intrare apa, 3/4 de scurgere

cod	mm	lei
802007	270x111x(H)115	217,99

**ELEMENT DE MONTARE PENTRU MASINA DE SPALAT CU DISC KITCHEN LINE**

cod	mm	lei
802014	302x115x(H)122	99,99





design by  
Robert Bronwasser



reddot winner 2024

# UNIQ

Buffet reinvented

Supiera si chafing dish

HENDI UNIQ

pagina 510



## LINGURI INGHEATATA

18/10  
stainless steel

### LINGURA INGHEATATA CU MANER TRITAN

cod	culoare	mm	lei
755808	Albastru	(L)260	28,99
755815	Rosu	(L)260	28,99
755822	Galben	(L)260	28,99
755839	Mov	(L)260	28,99



755556



755686



755655

**stöckel**



### LINGURA INGHEATATA STÖCKEL

cod	-	mm	lei
755556	1/20	ø56x120	175,99
755563	1/24	ø51x120	175,99
755570	1/30	ø49x120	175,99

### LINGURA INGHEATATA STÖCKEL

- Cu strat de ceramica.

cod	-	mm	lei
755686	1/20	ø56x170	284,99

### LINGURA INGHEATATA STÖCKEL

- Cu maner extra lung

cod	-	mm	lei
755655	1/20	ø56x170	241,99
755679	1/30	ø49x170	241,99



759301



### LINGURA PENTRU INGHEATATA

- Fabricat din aluminiu.
- Greutate redusa.
- Maner lung si confortabil pentru o portionare mai buna, ce are in compozitia interioara ulei - acesta se incalzeste prin caldura mainii, facilitand portionarea inghetatei.
- NOTA: Nu poate fi spalat in masina de spalat vase.

cod	-	mm	lei
759301	1/30	ø56x225	49,99



755730

S.S.  
stainless steel

### SUPPORT CORNETE INGHEATATA

- Pentru 3 cornete

cod	mm	lei
755730	200x95x(H)85	49,99



### VASCHETA PENTRU INGHEATA KITCHEN LINE

- Design solid
- Margini netede, usor de curatat
- Pot fi folosite in congelatoare

cod	litri	mm	lei
807019	5	360x165x(H)120	68,99



807019

304  
stainless steel

### VASCHETA PENTRU INGHEATA PROFI LINE

- De inalta calitate
- Grosime 0.8 mm
- Design solid
- Margini netede, usor de curatat
- Poate fi folosita in congelator

cod	litri	mm	lei
802045	3.6	360x165x(H)80	67,99
802052	5	360x250x(H)80	74,99
802038	5	360x165x(H)120	79,99
802021	6.5	360x165x(H)150	104,99



802021

802038

802045

802052



## RECIPIENT ROTUND PENTRU INGHEȚATA

- Produs profesional de cea mai înaltă calitate.
- Fabricat din oțel inoxidabil polizat, cu o grosime de 0,9 mm.
- Design extrem de robust.
- Marginile rotunjite facilitează curățarea.
- Poate fi utilizat în frigider și camere de congelare.
- Poate fi curățată în mașina de spălat vase.
- Capac vandut separat (802076).

cod	litri	mm	lei
807002	7	ø200x(H)245	124,99

304  
stainless steel



## CONTAINER ROTUND PENTRU INGHEȚATA

- Fabricat din oțel inoxidabil AISI 304 lustruit de 0,8 mm grosim
- Margini rotunjite pentru o curățare ușoară
- Poate fi folosit în frigider și congelatoare
- Se poate spăla în mașina de spălat vase
- Greutate netă: 1,04 kg
- Capac vandut separat (802076)

cod	litri	mm	lei
802083	7.3	ø200x(H)250	159,99

S.S.  
stainless steel



802076

807002  
802083

## CAPAC ROTUND PENTRU CONTAINERUL DE INGHEȚATA

- Fabricat din policarbonat
- Se poate spăla în mașina de spălat vase
- Potrivit pentru containerul 802083

PC  
polycarbonate



cod	ø	lungime (mm)	lei
802076	ø190	ø190	34,99

## CAPAC DIN POLICARBONAT PENTRU VASCHETA DE INGHEȚATA

- Potrivit pentru cutii de gunoi din policarbonat.

PC  
polycarbonate

cod	mm	lei
807088	360x165	24,99

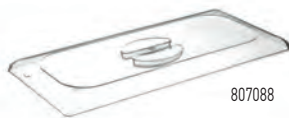

807088



807026

807057

PC  
polycarbonate

## VASCHETA DIN POLICARBONAT PENTRU INGHEȚATA

cod	culoare	litri	mm	lei
807026	Transparent	5	360x165x(H)120	39,99
807033	Negru	5	360x165x(H)120	44,99
807071	Negru	5	360x250x(H)80	44,99
807057	Transparent	5	360x250x(H)80	44,99



807033

807071





design by  
Robert Bronwasser



Motor puternic cu doua viteze.  
15.000 si 19.000 rpm.

2 seturi de  
agitatoare din  
policarbonat  
intocubile (cate  
2 bucati fiecare)



2 cesti: fabricate din otel  
inoxidabil (capacitate:  
0,95 l) si din policarbonat  
(capacitate: 0,9 l)

221631



221600

221617

221624

221631

221648

221655

### MILKSHAKER - DESIGN BY BRONWASSER

- Proiectat de designerul olandez Robert Bronwasser si disponibil in 6 culori atractive.
- Preparati cappuccino Freddo, Frappés si, desigur, milkshake-uri fara efort.
- Carcasa este fabricata din plastic ABS.
- Baza este cantarita pentru o stabilitate suplimentara si este prevazuta cu picioare din cauciuc.
- Motorul poate roti discul agitatorului la doua viteze, 15.000 si 19.000 RPM.
- Controlati mixerul de lapte cu comutatorul cu doua trepte din partea de sus, care este usor accesibil.
- Bateria de batere este prevazuta cu un microintrerupator, astfel incat sa poata functiona numai atunci cand cupa este asezata corect.
- Alegeti intre doua agitatoare diferite pentru a controla nivelul de aerare.
- Foarte complet, vine cu o ceasca de amestec din otel inoxidabil (0,95 litri) si o ceasca de amestec din policarbonat (0,9 litri) si 2 seturi de 2 agitatoare.
- Cupele si agitatorii sunt sigure pentru masina de spalat vase.

cod	culoare	V	W	mm	lei
221617	Alb	230	400	170x210x(H)485	<b>549,99</b>
221600	Negru	230	400	170x210x(H)485	<b>549,99</b>
221624	Caramel	230	400	170x210x(H)485	<b>549,99</b>
221631	Galben	230	400	170x210x(H)485	<b>549,99</b>
221648	Rosu	230	400	170x210x(H)485	<b>549,99</b>
221655	Albastru	230	400	170x210x(H)485	<b>549,99</b>

PREPARA  
FREDDO  
CAPPUCCINO,  
FRAPPE-URI  
SI MILKSHAKE-URI  
FARA EFORT



221617



221600



221624



961124



961117



961131

### CANA DE AMESTECARE DIN POLICARBONAT PENTRU MIXER MILKSHAKE - DESIGN DE BRONWASSER

- Fabricat din otel inoxidabil
- Proiectat pentru shakererele de cocktail de lapte: 221600, 221617, 221624, 221631, 221648, 221655.
- Potrivit pentru spalare in masina de spalat vase

cod	mm	lei
961124	ø116x(H)161	39,99

### CANA DE AMESTECARE DIN OTEL INOXIDABIL PENTRU MIXER MILKSHAKE - DESIGN DE BRONWASSER

- Fabricat din otel inoxidabil
- Proiectat pentru shakererele de cocktail de lapte: 221600, 221617, 221624, 221631, 221648, 221655.
- Potrivit pentru spalare in masina de spalat vase

cod	mm	lei
961117	ø113x(H)160	64,99

### AGITATOR PENTRU MILKSHAKER - DESIGN REALIZAT DE BRONWASSER

- Fabricat din policarbonat.
- Setul include 2 bucati: un agitator simplu si dublu.
- Creat special pentru mixerele Milkshake HENDI - Design de Bronwasser: codurile 221600, 221617, 221624, 221631, 221648, 221655, 221495.
- Poate fi spalat in masina de spalat vase.

cod	mm	lei
961131	32x27x(H)50	39,99





Non-toxic ————— Pentru preparate calde si reci  
Puternic si durabil ————— Inodor

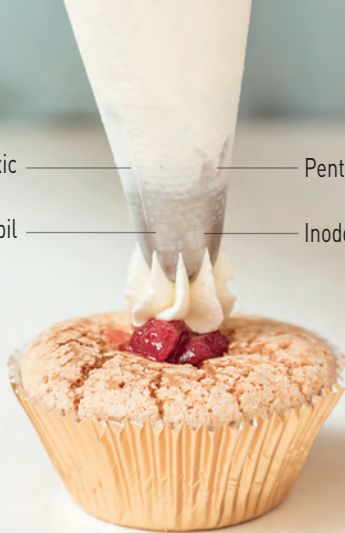

557105



### PUNGI PATISERIE

- De unica folosinta
- Potrivite pentru preparare calda si rece
- Conforme normelor HACCP de igiena
- Grosime material 80 microni
- Rola de 100 bucati, in cutie

cod	mm	lei
557112	445x220	<b>44,99</b>
557105	530x285	<b>61,99</b>



557303



### PUNGI PATISERIE, ANTI-ALUNECARE - 100 BUCATI

- Pungi de unica folosinta
- Potrivite pentru preparare calda si rece
- Conforme normelor HACCP de igiena
- Grosime material 80 microni
- Rola de 100 bucati, in cutie

cod	ambalat pe	mm	lei
557303	100	515x280	<b>79,99</b>



### POSH PATISERIE - 2 BUCATI

- Bumbac, interior tratat cu poliuretan
- Cu eticheta
- Adecvate pentru curatarea in apa fierbinte

cod	ambalat pe	mm	lei
550120	2	(L)300	32,99
550229	2	(L)350	35,99
550328	2	(L)400	40,99
550427	2	(L)450	45,99
550526	2	(L)500	49,99

### PUNGI PATISERIE

- Fabricate din nailon de calitate inalta fara sudura
- Solide, cu o eticheta.
- Adecvate pentru curatarea in apa fierbinte.



cod	ambalat pe	mm	lei
550106	1	(L)300	29,99
550205	1	(L)350	32,99
550304	1	(L)400	34,99
550403	1	(L)450	39,99
550502	1	(L)500	42,99



Recomandat



### SUPORT PENTRU PERETE PENTRU PUNGI DE PATISERIE

- Cu 4 sloturi pentru agatat pungi de patiserie, 31 suporturi pentru depozitarea varfurii de patiserie, 7 carlige pentru a atarna ustensile precum spatule si un suport pentru accesorii mici.

cod	mm	lei
550113	500x360x(H)560	189,99





## DUIURI - ZIMTATE



Ø14 Ø12 Ø10 Ø8 Ø6



551790

## DUIURI - ZIMTATE

- Set 5 dimensiuni

cod	-	lei
551790	Ø6-8-10-12-14	50,99



551714

## VARFURI PENTRU DECORARE PATISERIE, ONDULATE

- Set 7 dimensiuni

cod	-	lei
551714	Ø6-8-10-12-14-16-18	59,99

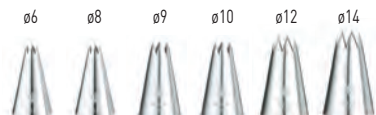

551370 551387 551271 551394 551424 551431

## VARF DECORARE - STEA DESCHISA

cod	mm	lei
551370	Ø6	10,99
551387	Ø8	10,99
551271	Ø9	10,99
551394	Ø10	13,99
551424	Ø12	13,99
551431	Ø14	13,99



551110

## DUIURI - ZIMTATE

- Set 7 dimensiuni

cod	-	lei
551110	Ø 3-5-7-9-11-13-15	27,99



## DUIURI - NETEDE



Ø10 Ø8 Ø6 Ø4 Ø2



551691

## DUIURI - NETEDE

- Set 5 dimensiuni

cod	-	lei
551691	Ø2-4-6-8-10	49,99

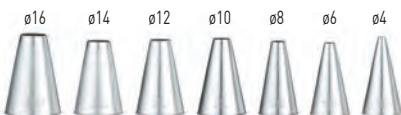

551615

## VARFURI PENTRU DECORARE PATISERIE, DREPTE

- Set 7 dimensiuni

cod	-	lei
551615	Ø4-6-8-10-12-14-16	79,99

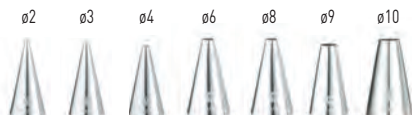

551325 551295 551332 551349 551356 551264 551363

## VARF DECORARE - ROTUND

cod	mm	lei
551325	Ø2	10,99
551295	Ø3	10,99
551332	Ø4	10,99
551349	Ø6	10,99
551356	Ø8	10,99
551264	Ø9	10,99
551363	Ø10	10,99



551011

## DUIURI - NETEDE

- Set 7 dimensiuni

cod	-	lei
551011	Ø 5-7-9-11-13-15-17	27,99





Vezi filmul

18/10  
stainless steel



551592

### SET DUIURI PENTRU UMPLERE SI DECORARE

- Setul contine 5 duiuri ornare pentru:

- Umplere
- Macarons
- Decorare
- Ornare ondulata
- Scriere

- Foarte precise datorita marginilor ascutite

cod	lei
551592	49,99



551202

### VARF DECORARE FLOARE & PETALA

- Setul contine 5 varfuri pentru decorarea:

- 2 varfuri inchise tip stea
- 1 varf tip floare
- 1 varf francezesc tip stea
- 1 varf in forma de V

- Foarte precise datorita marginilor ascutite

cod	lei
551202	45,99



### VARF DECORARE - FLOARE

cod	mm	lei
551219	ø10	10,99

### VARF DECORARE - STEA FRANCEZA

cod	mm	lei
551226	ø11	10,99

### VARF DECORARE - IN FORMA DE V

cod	mm	lei
551233	ø14	10,99



### VARF DECORARE

cod	mm	lei
551240	ø7	16,99
551257	ø4	19,99

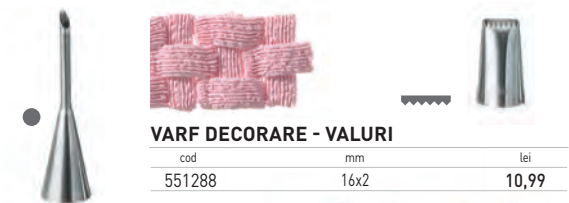

### VARF DECORARE - VALURI

cod	mm	lei
551288	16x2	10,99

### DUIURI - ASORTATE

- Set de 12 duiuri diferite, ambalate in cutie

cod	lei
551400	59,99



551400



### FORMA BABA

cod	-	mm	lei
689806	cu margine neteda	ø70x(H)68	20,99
689608	cu margine rulata	ø70x(H)68	20,99



689608

689806



### FORMA CHEC

- Dreptunghiulara

cod	mm	lei
682104	180x80x(H)60	49,99
682302	260x100x(H)75	54,99
682401	300x110x(H)75	69,99

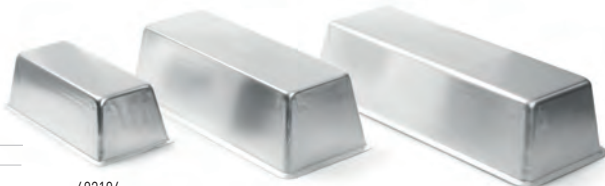

682104

682302

682401



Vezi filmul



Vezi filmul



512227

512234

512166

512173



512203

512210

512142

512159



512135

512104

512302

### INEL SI PRESA DECORARE - PATRAT

cod	-	mm	lei
512166	inel	65x65x(H)45	17,99
512173	inel	80x80x(H)45	20,99
512227	presa	63x63x(H)55	10,99
512234	presa	80x80x(H)55	11,59

### INEL ROTUND

cod	-	mm	lei
512142	inel	ø80x(H)45	16,99
512159	inel	ø100x(H)45	16,99
512203	presa	ø80x(H)55	9,39
512210	presa	ø100x(H)55	14,99

### INEL PENTRU DECORARE ROTUND

cod	mm	lei
512135	ø60x(H)45	11,99
512104	ø70x(H)45	14,99
512302	ø90x(H)45	15,99

673782

**SET DECUPARE ALUAT - FLUTURE**

- Set de 8 dimensiuni diferite.

cod	mm	lei
673782	(H)20	43,99



Vezi filmut

673768

**SET PENTRU DECUPARE ALUAT**

- Set de 9 dimensiuni diferite.

cod	-	mm	lei
673768	stea	(H)30	44,99



673775

**SET PENTRU DECUPARE ALUAT - TRIUNGHIULAR**

- Set de 6 dimensiuni diferite.

cod	mm	lei
673775	(H)50	51,99

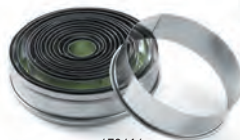

673416

**SET FORME PATISERIE**

- 14 piese, model rotund

cod	-	mm	lei
673416	cu margine simpla, $\phi$ 19-112	(H)35	53,99
674413	cu margine striata, $\phi$ 18-108	(H)35	59,99



674413



855751

**TAIETOR ALUAT**

- Otel inoxidabil cu maner din polipropilena

cod	mm	lei
855751	150x110	24,99



553404

**TAIETOR ALUAT**

- Otel inoxidabil cu maner din polipropilena

cod	mm	lei
553404	150x110	19,99





677810

### SUPORT COACERE ANTI-ADERENT DIN SILICON

cod	grosime (mm)	mm	lei
677827	0.7	600x400	<b>68,99</b>
677810	0.7	530x325	<b>51,99</b>
677834	0.7	300x400	<b>49,99</b>



677018

### COVARAS DE COPT DIN SILICON ANTIADERENT

- Confectionata 100% din silicon neaderent

- Negru

cod	mm	lei
677018	300x400	<b>69,99</b>

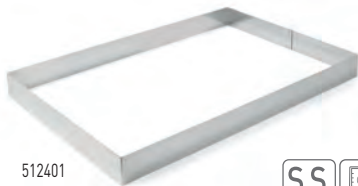

512401



### FORMA DREPTUNGIULARA PENTRU PATISERIE SI COFETARIE

- Otel inoxidabil, grosimea 1.5 mm.

cod	mm	lei
512418	383x285x(H)50	<b>84,99</b>
512432	385x285x(H)60	<b>94,99</b>
512401	585x385x(H)50	<b>119,99</b>
512425	585x385x(H)60	<b>119,99</b>



512296



### FORMA PENTRU PANIFICATIE SI PATISERIE - ROTUNDA

- Otel inoxidabil de 1,5 mm grosime

cod	mm	lei
512241	ø140x(H)50	<b>43,99</b>
512340	ø140x(H)60	<b>44,99</b>
512258	ø160x(H)50	<b>50,99</b>
512357	ø160x(H)60	<b>49,99</b>
512265	ø180x(H)50	<b>50,99</b>
512364	ø180x(H)60	<b>59,99</b>
512272	ø200x(H)50	<b>54,99</b>
512371	ø200x(H)60	<b>57,99</b>
512289	ø220x(H)50	<b>59,99</b>
512388	ø220x(H)60	<b>59,99</b>
512296	ø240x(H)50	<b>64,99</b>
512395	ø240x(H)60	<b>64,99</b>

## PENSULA PENTRU UNT SI GRASIME

- Cu peri din otel inoxidabil.
- Rezistent la temperaturi ridicate.



cod	mm	lei
515389	200x25	24,99
515396	220x50	34,99



515389



515396



515228



515327

## PENSULA PENTRU UNT SI GRASIME - 2 BUCATI

- Cu maner din lemn



cod	ambalat pe	mm	lei
515228	2	190x20	17,99
515327	2	210x40	29,99



515358



515365

## PENSULA DIN SILICON PENTRU UNT SI GRASIME

- Cu maner din polipropilena



cod	mm	lei
515358	220x32	13,99
515365	230x45	16,99



833032



Vezi filmul



## CRATITA BAIN-MARIE

- Pereti dubli, cu rezervor pentru apa.
- Umpleti rezervorul cu apa pentru a topi ciocolata la bain-marie.
- Cu maner din otel inoxidabil.

cod	litri	mm	lei
833032	1	330x165x(H)95	79,99



**RACLETA PENTRU ALUAT**

- Racleta din polipropilena.
- Potrivita pentru masina de spalat vase.
- Racletele dreptunghiulare, semicirculare si trapezoidale pentru aluat sunt disponibile fie separat, fie in seturi de 6 bucati.

6x



554142

6x



554197

**RAZUIITOR ALUAT - 6 BUCATI**

cod	ambalat pe	mm	lei
554142	6	104x74	34,99

**RAZUIITOR ALUAT - 6 BUCATI**

cod	ambalat pe	mm	lei
554197	6	130x100	34,99

6x

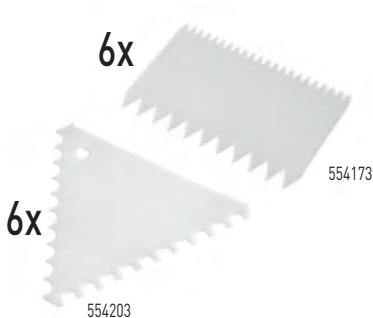

554173

6x

554203

**RAZUIITOR ALUAT - 6 BUCATI**

- Cu polipropilena.
- Dreptunghiular cu margini zimtate.

cod	ambalat pe	mm	lei
554173	6	110x72	34,99

**RAZUIITOR ALUAT - 6 BUCATI**

- Cu polipropilena.
- Triunghiular cu margini zimtate.

cod	-	ambalat pe	mm	lei
554203	dinti mari	6	110x110x(H)	34,99
554210	dinti mici	6	110x110x(H)	34,99



## RACLETA PENTRU ALUAT

- Racleta din polipropilena.
- Potrivita pentru masina de spalat vase.
- Racletele dreptunghiulare, semicirculare si trapezoidale pentru aluat sunt disponibile fie separat, fie in seturi de 6 bucati.

**NOU**



554258

### RACLETA PENTRU ALUAT SEMICIRCULARA

cod	mm	lei
554258	120x88	2,99

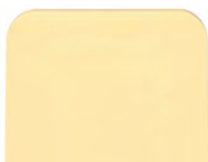

554265

### RACLETA DREPTUNGIULARA PENTRU ALUAT

cod	mm	lei
554265	120x96	2,49



554272

### RACLETA TRAPEZOIDALA PENTRU ALUAT

cod	mm	lei
554272	216x128	4,99



6x

554166

### RAZUIITOR FLEXIBIL ALUAT - 6 BUCATI

- Semi-circular

cod	ambalat pe	mm	lei
554166	6	120x88	12,99



6x

554364

### RAZUIITOR ALUAT - 6 BUCATI

cod	ambalat pe	mm	lei
554364	6	120x96	12,99



3x

554432

### RAZUIITOR ALUAT - 3 BUCATI

cod	ambalat pe	mm	lei
554432	3	216x128	15,99

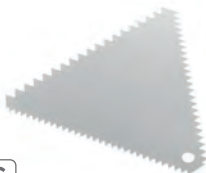

554227

### RAZUIITOR ALUAT

- Otel inoxidabil.
- Triunghiular cu margini zimtate.

cod	mm	lei
554227	110x110	29,99



554234

### RAZUIITOR ALUAT

- Otel inoxidabil.
- Dreptunghiular cu margini zimtate.

cod	mm	lei
554234	102x69	29,99





855775

855782

855683



Vezi filmul



855706

855690

855744

## CUTIT PALETA

- Cu lama flexibila

cod	grosime (mm)	lungimea lamei (mm)	lungime (mm)	lei
855775	0.7	110	220	<b>26,99</b>
855782	0.7	200	343	<b>36,99</b>
855683	0.7	254	390	<b>37,99</b>

## PALETA

- Pentru produse de cofetarie

- Lama neteda, flexibila

cod	grosime (mm)	lungimea lamei (mm)	lungime (mm)	lei
855706	0.5	110	220	<b>26,99</b>
855690	0.5	203	345	<b>29,99</b>
855744	0.5	255	400	<b>39,99</b>



- Lama din otel de inalta calitate AISI 420.
- Maner fabricat din termoplastice SEBS.
- Duritate: 56-58 HRC.

cod	nr.	nume	grosime (mm)	lungimea lamei/lungime (mm)	lei
S719.008	1	Spatula triunghiulara	1,5	210/80	<b>59,99</b>
S773.015	2	Spatula lasagna	1,5	280/150	<b>97,99</b>
S772.020	3	Spatula patiserie, plata	1,5	480/350	<b>68,99</b>
S772.027	4	Spatula patiserie, plata	1,5	330/200	<b>86,99</b>
S772.035	5	Spatula patiserie, plata	1,5	400/270	<b>104,99</b>
S780.026	6	Spatula patiserie-curbata	1,5	390/260	<b>88,99</b>
SZ22042B	7	Spatula cu doua manere	1,4	705/420	<b>150,99</b>

**NOU**

7

Gratar ptibil  
pentru gogosa



205914

### FRITEUZA ADANCA PENTRU GOGOSI 12 L

- Ideal pentru prajit gogosi, angel wings, beignets, gogosi olandeze si alte produse de patiserie din aluat.
- In intregime din otel inoxidabil, vine cu doua grilaje de prajire (354x383 mm) cu maner rece la atingere, cu protectie de incalzire si un capac care poate servi si ca tava pentru picurare.
- Usor de utilizat si curat, potrivit pentru utilizare intensa si cantitati mari.
- Montat cu un rezervor mare de ulei sudat (400x400x (H)160 mm) cu o presiune maxima. capacitate de 12 litri.
- Rezervorul echipat cu robinet de scurgere si marcajul nivelului uleiului min / max, are o zona rece pentru imbunatatirea duratei de utilizare a uleiurilor.
- Element de caldura detasabil cu functie de oprire la demontare si protectie la supraincalzire.
- Temperatura poate fi setata de la 50 ° pana la 190 ° C.
- Lampa indicatoare de incalzire pentru a arata daca elementul de incalzire functioneaza.
- Cu picioare anti-alunecare din cauciuc.



Un sistem „zona rece”  
care separa reziduurile  
de frigere de sub nivelul  
incalzitului

Robinet de  
scurgere

cod	litri	V	W	mm	lei
205914	12	230	3500	630x860x(H)438	1599,00





195789

### CHITARA PENTRU PATISERIE

- Instrument pentru taiere longitudinala precisa si pentru portionarea rapida a produselor de cofetarie moi, cum ar fi ganache, cremelor, bezelei, pralinelor si portionarea prajiturilor pentru banchet.
- Design negru atragator: cadru de baza si cadru cu corzi, realizat din aluminiu anodizat negru.
- Zona de lucru si placa fabricate din otel inoxidabil - este garantata durabilitatea si curatarea usoara.
- Siruri fabricate din otel chirurgical igienic.
- Zona de lucru profilata si firele ascutite garanteaza o operare precisa; taierea cu precizie chirurgicala.
- Balamalele cu design special sunt realizate din alama - o durata lunga de viata a produsului, spre deosebire de alte produse de pe piata, care au balamale din plastic.
- Picioarele anti-alunecare asigura stabilitate in timpul functionarii.
- Inclus in set:
  - 1 baza cu dimensiuni de 600x400x(H)100 mm,
  - 3 cadre de taiere:
  - 9 corzi cu spatiere de 45 mm
  - 13 corzi cu spatiere de 30 mm
  - 17 corzi cu spatiere de 22,5 mm
  - placa de otel,
  - cheie pentru schimbarea corzilor

cod	mm	lei
195789	636x441x(H)109	4699,00

### Beneficii:

- Imbunatatirea productiei in patiserie, brutarii si catering puncte.
- Precizie ridicata: taierea produselor de patiserie, prajituri, mousse-uri in mai multe bucati egale, fara deformare si rupere - chitarii pentru patiserie cu corzi plasate in diverse combinatii dimensionale.
- Aplicarea eficienta si fara efort a produselor de patiserie si preluarea produsului taiat de pe chitara datorita placii din otel inoxidabil inclusa in set.
- Este posibila determinarea cu precizie a greutatii fiecarui capat taiat produs cu structura adecvata a gramajului de patiserie.
- Principiul de functionare simplu permite taierea perfecta a produselor de patiserie
- Usor de asamblat, dezasamblat si de mentinut igiena.



3 rame de taiere cu distanta intre siruri pentru taierea la:  
22,5 mm (17 siruri), 30 mm (13 siruri) si 45 mm (9 siruri)



## FELIATOR PENTRU PANDISPAN

- Design negru atragator: corp realizat din aluminiu anodizat igienic.
- Lama din otel inoxidabil, usor de demontat si care poate fi spalata in masina de spalat vase - garantand o igiena locului de munca.
- Picioare din PTFE, care asigura o utilizare confortabila pe fiecare blat de lucru.
- Lama de taiere este stransa corespunzator si fixata pe un element frezat - aceasta nu se indoiaie si nu se rotește in timpul functionarii.
- Orificiile pentru lama sunt aceleasi pe ambele parti - capacul poate fi atasat atat pe partea stanga, cat si pe partea dreapta.
- Dotata cu o masura amplasata pe corp - pentru reglarea grosimii straturilor de pandispan: de la 1 cm la 6 cm.
- Interval de dimensiuni de feliere a pandispanului in conformitate cu standardul pentru cofetarie: 60x40 cm.
- Este posibila taierea cu precizie a unui pandispan rotund cu diametru: de la ,5 cm la ,40 cm.
- Lungime lama: 57 cm, cu inaltime reglata conform masuratorii.

cod	mm	lei
400098	620x120x(H)130	699,99

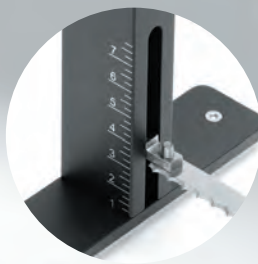

841068

### Beneficii:

- Accelerarea procesului de taiere a pandispanului cu pana la 50%.
- Reducerea pierderilor de productie in timpul procesului de taiere a pandispanului cu 20%.
- Masura permite o taiere precisa fara necesitatea de a utiliza instrumente suplimentare - intotdeauna se obtine acelasi efect vizual al stratului de pandispan pentru tort
- Operare confortabila: lama feliatorului este corect stransa si fixata pe un element frezat - nu se indoiaie si nu se rotește in timpul functionarii.





18/8

stainless steel



515044



Vezi filmul



515150

### TAIETOR PENTRU ALUAT CU 5 ROTI

- Latimea de taiere poate fi usor ajustata.
- Cu 5 rotii netede din otel inoxidabil ø55 mm.

cod	mm	lei
515044	222x56x(H)55	259,99

### TAIETOR PENTRU ALUAT CU 7 ROTI

- Latimea de taiere poate fi usor ajustata.
- Cu 7 rotii netede din otel inoxidabil ø55 mm.

cod	mm	lei
515150	222x80x(H)55	349,99



S.S.  
stainless steel



512500



Vezi filmul

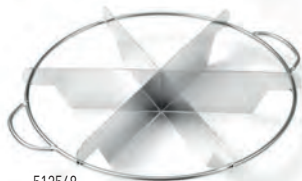

512548

### TAIETOR PENTRU PLACINTA

- Pentru a taia o placinta rotunda sau o prajitura in parti egale.

cod	-	mm	lei
512500	Taietor pentru placinta	ø320	150,99
512517	Taietor pentru placinta, 12 portii	ø320	174,99
512531	Taietor pentru placinta	ø320	194,99

### TAIETOR PENTRU PLACINTA

- Pentru a taia o placinta rotunda sau o prajitura in parti egale.

cod	-	mm	lei
512548	Taietor pentru placinta	ø270	96,99
512555	Taietor pentru placinta	ø270	104,99





637791



pentru  
zahar pudra  
0,5x0,5 mm

pentru faina si  
gris marimea  
1x1 mm

pentru pesmet  
cu dimensiunea  
de 3 x 3 mm

**NOU**

18/0  
stainless steel

18/10  
stainless steel

food contact



637852



## SITA BRUTARIE

- Cu cartilaj agatare

cod		mm	lei
637791	pentru zahar pudra	ø250x(H)75	40,99
637821	pentru zahar pudra	ø410x(H)80	84,99
637807	pentru faina si gris	ø250x(H)75	38,99
637838	pentru faina si gris	ø410x(H)80	69,99
637814	pentru pesmet	ø250x(H)75	44,99
637845	pentru pesmet	ø410x(H)80	74,99

## CANA PENTRU CERNEREA FAINII

- Corp fabricat din otel inoxidabil, plasa fabricata din otel inoxidabil.
- 2 straturi de plasa foarte fina.
- Cu un maner de strangere (mecanism cu arc).
- Capacitate: - 550 g.
- Potrivita pentru masina de spalat vase.

cod	mm	lei
637852	187x125x(H)127	33,99



**NOU**

## TAVA DE RACIRE PENTRU PRAJITURI

- Fabricat din otel inoxidabil cu picior integrat.

- Intrebuintari multiple:

- pentru racirea prajiturilor - previne adunarea umiditatii excesive in prajitura ca rezultat al vaporizarii caldurii,
- pentru decorarea prajiturilor, de exemplu, atunci cand turnati glazura sau ciocolata,
- ca gratar si gratar pentru tigaele - faciliteaza eliminarea grasimii din carnea prajita,
- ca protectie pentru blatul de lucru pe care urmeaza sa se puna un vas fierbinte,
- ca baza stabila pentru matritele din silikon.
- Grosimea firului - margine: 3 mm.
- Grosimea firului - grila: 1,7 mm.

cod	mm	lei
594032	ø320x(H)20	39,99



594032



659304



659403

### SPATULA

- Maner din ABS
- Lama din cauciuc sintetic



cod	lungimea lamei (mm)	mm	lei
659205	90	52x257	<b>13,99</b>
659304	116	70x358	<b>16,99</b>
659403	116	70x410	<b>24,99</b>



659007



659106

### SPATULA

- Maner din PA
- Lama din silikon



cod	lungimea lamei (mm)	mm	lei
659014	90	55x266	<b>20,99</b>
659007	105	70x354	<b>33,99</b>
659106	105	70x420	<b>31,99</b>



658604



658802



658901

### SPATULA

- Maner din fibra de sticla armata cu naylon
- Lama din cauciuc natural
- Potrivita doar pentru produse reci



cod	lungimea lamei (mm)	mm	lei
658604	90	55x260	<b>24,99</b>
658703	90	75x320	<b>44,99</b>
658802	90	75x425	<b>49,99</b>
658901	150	100x515	<b>89,99</b>



659458



659458



659472

### SPATULA IN FORMA DE LINGURA

- Maner din ABS
- Lama din cauciuc sintetic



cod	lungimea lamei (mm)	mm	lei
659472	117	75x408	<b>26,99</b>
659458	88	57x254	<b>18,99</b>
659465	117	75x357	<b>27,99</b>



563007



563106



### LINGURA BUCATARIE PBT

cod	mm	lei
563007	375x70	<b>25,99</b>
563106	450x80	<b>34,99</b>
563205	575x105	<b>50,99</b>



659700



659809

### LINGURA EXOGLASS

- Fabricata din material Exoglass



cod	mm	lei
659700	(L)305	<b>44,99</b>
659809	(L)385	<b>59,99</b>



**NOU**

**SUCITOR DIN LEMN**

- Fabricat din lemn de fag solid.
- Cu rulmenti cu bile din otel nichelat, care functioneaza lin.
- Manere ergonomice, conturate.
- Un ax metalic robust in interior intareste structura sucitorului.
- Datorita dimensiunii si greutatii sale, sucitorul de lemn este adecvat pentru intinderea unei cantitati mari de aluat.
- Nu poate fi spalat in masina de spalat vase.



Fabricat din lemn de fag solid



Cu rulmenti cu bile din otel nichelat, care functioneaza usor

cod	mm	lei
515020	ø75x640	159,99
515167	ø90x667	221,99

**SUCITOR**

- Cu rulmenti cu bile

cod	mm	lei
515006	ø62x470	109,99



**SUCITOR CU STRAT ANTIADERENT**

- Otel inoxidabil cu invelits anti-tipire
- Cu rulmenti cu bile
- Include suport placat cu crom



Vezi filmul

cod	mm	lei
515013	ø62x470	159,99

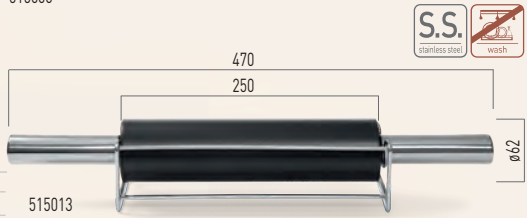



## SUCITOR ALUAT



### ROLA CU SPINI PENTRU ALUAT

- Latimea rolei: 70 mm.

cod	mm	lei
515099	85x210	78,99

### ROLA CU SPINI PENTRU ALUAT

- Latimea rolei: 120 mm.

cod	mm	lei
515112	140x210	89,99

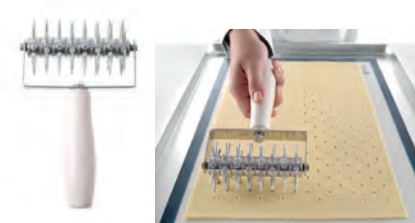

### ROLA CU SPINI PENTRU ALUAT

- Latimea rolei: 70 mm.

- Cu role din otel inoxidabil.

cod	mm	lei
515136	80x210	98,99

### ROLA CU SPINI PENTRU ALUAT

- Latimea rolei: 120 mm.

- Cu role din otel inoxidabil.

cod	mm	lei
515143	140x210	118,99



Vezi filmul



Spini durabili, din inox



### ROLA PENTRU ALUAT

- Latimea rolei: 120 mm

- Cu roti de taiere din otel inoxidabil.

cod	mm	lei
515129	135x200	128,99



### ROLA CU SPINI PENTRU ALUAT

- Rola de 60 mm cu 32 varfuri de plastic lungi, durabile pentru a manipula aluatul gros.
- Poate fi folosit pe aluat pentru a preveni bulele excesive de aer.
- Utilizati-l pentru a preveni cresterea nedorita sau formarea de bule.

cod	mm	lei
515037	210x73	35,99



### ROLA PENTRU ALUAT CU GHEARE

- Latimea rolei: 60 mm

cod	mm	lei
515068	80x210	23,99



### ROLA PENTRU ALUAT

- Latimea rolei: 120 mm

cod	mm	lei
515075	130x200	31,99



## FORME COPT DIN SILICON

- 100% strat silicon anti-aderent.



677001

### MINI-CAKE

cod	dimensiune forma	dimensiune produs (mm)	nr. de produse	lei
677001	GN 1/3	80x30x(H)33	9	<b>52,99</b>



676509

### TARTELETTE

cod	dimensiune forma	dimensiune produs (mm)	nr. de produse	lei
676509	GN 1/3	ø50x(H)17	15	<b>54,99</b>



676905

### MUFFINS

cod	dimensiune forma	dimensiune produs (mm)	nr. de produse	lei
677209	GN 1/3	ø69x(H)40	6	<b>54,99</b>
676905	GN 1/3	ø53x(H)30	11	<b>52,99</b>



677308

### MADELEINES

cod	dimensiune forma	dimensiune produs (mm)	nr. de produse	lei
677308	GN 1/3	42x29x(H)11	20	<b>55,99</b>



## MULAJE DIN SILICON

- Fabricat din silicon 100% antiaderent.
- Perfect pentru: coacere, congelare, crearea de monoportii.
- Rezistent la temperatura: de la -30°C la 230°C.
- Poate fi folosit la microunde si in masina de spalat vase.



**NOU**

### FORMA DIN SILICON SQUARE

- Forme patrate cu dimensiuni de 5,5x5,5 cm.

cod	mucegaiuri	mm	lei
677261	35	570x375x(H)25	155,99



677261

### FORMA DIN SILICON HEART

- Forme in forma de inima cu dimensiuni de 7,5x6 cm.

cod	mucegaiuri	mm	lei
677254	20	570x375x(H)35	150,99



677254

### FORMA DE SILICON OVAL

- Forme ovale cu dimensiuni de 5x3 cm.

cod	mucegaiuri	mm	lei
677247	50	570x375x(H)20	164,99



677247

### FORMA DIN SILICON MINI-MUFFIN

- Forme rotunde cu diametrul de 3,5 cm, perfecte pentru mini briose.

cod	mucegaiuri	mm	lei
677230	48	570x375x(H)25	150,99



677230

### MUFFIN FORMA DIN SILICON

- Forme rotunde cu diametrul de 7 cm, perfecte pentru briose.

cod	mucegaiuri	mm	lei
677223	24	570x375x(H)40	174,99



677223

### FORMA DIN SILICON SEMI-SPHERE

- Matrite semicirculare cu diametrul ø7 cm.

cod	mucegaiuri	mm	lei
677216	24	600x395x(H)35	162,99



677216



**STABILIZATOR DE TEMPERATURA**

Din prima secunda de operare, arzatorul atinge valoarea optima temperatura flacara de 1300 °C

**PRIZE DE AER TIP GILL**

Prize de aer in camera de ardere cu capacitate crescuta.

FLACARA PUTERNICA, ARDERE FARA FUM



design by  
Robert Bronwasser

**CONTROL PRECIS AL FLACARII**

Ideal pentru rumenire: zaharuri, proteine, branzeturi, fructe, legume si carne  
CONTROL LUNGIME FLACARA DE LA 15 LA 150 MM

**DUZE ARDERE 100 mm**

- flambare facila
- amplasarea precisa a zonei de foc si a zonei de tratament termic
- separarea maxima a mainii de la temperatura ridicata CONFORT si LIBERTATE

**INSTALARE RAPIDA**

Indicatorul SIGURANTA de pe CAPAC va permite sa instalati rapid cartusul. Un clic si cartusul de gaz este inlocuit  
IN SIGURANTA.

**HENDI JET ARZATOR CRÈME-BRÛLÉE**

- Proiectat de Robert Bronwasser pentru bucatarii profesionisti.
- Design modern: negru mat cu accent verde.
- Instalare usoara si sigura a arzatorului pe cartusul de gaz (cartusul poate fi inlocuit cand gazul este epuizat).
- Aprinderea piezoelectrica faciliteaza aprinderea.
- Functioneaza in orice unghi sau pozitie - chiar si cu flacara indreptata in sus - datorita unui design special care previne dispersarea flacarii.
- Control precis al flacarii, pana la o lungime a flacarii de 150 mm.
- Cartusul de gaz nu este inclus in set.
- Cartusele pot fi achizitionate separat, cod: 199039.

198254



cod	-	mm	lei
198247	Doar arzator	185x65x(H)100	<b>69,99</b>
198254	Set arzator si butelie	175x68x(H)260	<b>109,99</b>



360°

#### ANTI-FLARE

- sistem DIRECTIONAL de pulverizare / 360 grade
- flacara nu se retrage spre arzator si mana VERSATIL SI SIGUR

#### ARZATORUL

Fabricat din plastic rezistent si o supapa cu o singura trecere, ofera protectie permanenta impotriva interferentei flacarilor de la preparatele rumenite cu supapa de gaz in timpul lucrului SIGURANTA



#### CONCEPUT PENTRU A FI VIZIBIL

Culorile contrastante va permit sa localizati imediat dispozitivul printre ustensilele de bucatarie

#### DE INCREDERE

Aprinzatorul foloseste descarcarea electrica care apare pe suprafata cristalului ca urmare a unei interactiuni mecanice

DOAR APASATI SI FUNCTIONEAZA  
- NU ESTE NECESARA INLOCUIREA PIETRELOR ABRAZIVE SAU  
ACHIZITIONAREA UNUI ALT ARZATOR

#### GANDIT PENTRU ORICE PROVOCARE CULINARA

Usor si rezistent datorita structurii arzatorului si a materialelor de inalta calitate.  
NU ACHIZITIONATI UN ARZATOR, CI UN ACCESORIU CARE VA REZISTA IN TIMP



199039

#### BUTELII DE GAZ BUTAN

- Potrivite numai in combinatie cu aragazul portabil (147610) si arzatorul pentru Crème-Brûlée anti-palpaire (198216 & 198247).
- Nu sunt adecvate pentru reumplerea brichetelor etc.
- Set de 4 butelii

cod	ambalat pe	lei
199039	4	29,99



# Intotdeauna la zi!

Catalogul nostru este, de asemenea, disponibil online cu functii interesante precum:

- + instrument de cautare rapid si facil
- + navigare usoara
- + partajare rapida.

Dar cel mai important, **preturi la zi.**



Scaneaza  
si urmareste



## BINE AI VENIT LA CATALOG DIGITAL HENDI

PRIETENOS / FUNCȚIONAL / ECOLOGIC

- + USOR DE FOLOSIT
- + ACCESARE USOARA A CAPITOLELOR DIN CATALOG
- + ACCESARE FACILA A FUNCTIEI DE CAUTARE
- + MAI MULTE INFORMATII DESPRE PRODUS / POZE / VIDEO
- + CREAZĂ-ȚI PROPRIUL CATALOG
- + PARTAJARE CU UN CLICK



Vezi filmul



198209



198223



199008

### ARZATOR CRÈME-BRÛLÉE

- Funcționează cu gaz, reincarcabil - aprindere automată.
- Arzatorul se distribuie neincarcat.
- Complet cu baza.

cod	mm	lei
198209	145x70x(H)190	159,99

### ARZATOR CRÈME-BRÛLÉE

- Funcționează cu gaz, reincarcabil - aprindere automată.
- Arzatorul se distribuie neincarcat.
- Complet cu baza.

cod	mm	lei
198223	115x50x(H)155	74,99

### CANISTRA GAZ

- Cu duze diferite de umplere

cod	ambalat pe	litri	lei
199046	4	0.2	45,99
199008	1	0.2	8,99



783153

783160

783177

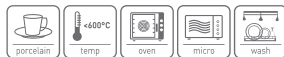

### RAMEKIN

- Striat

cod	unitate de comanda	mm	lei
783153	12	ø70x(H)35	12,99
783160	6	ø90x(H)48	13,99
783627	6	ø100x(H)25	15,99
783177	6	ø120x(H)55	19,99





Vezi filmul

## APARAT DE PREPARAT VAFE ROTUND

- O propunere ideala pentru toate tipurile de unitati gastronomice care doresc sa-si extinda oferta cu vafe delicioase in stil belgian, o solutie perfecta si pentru bufetele de mic dejun self-service din hoteluri
- Capacitate: pana la 20 de vafe pe ora
- Prese fabricate din aluminiu turnat emailat, pot fi curatate cu o perie.
- Dimensiune placheta: diametru  $\varnothing$  190 mm, grosime pana la 23 mm
- Reglarea temperaturii fara trepte, prin intermediul unui termostat, in intervalul de la 50°C la 220°C
- Cronometru: pana la 15 minute

cod	V	W	mm	lei
212172	230	1000	250x491x(H)285	584,99



- Perfect pentru toate tipurile de unitati de catering care doresc sa adauge aceste vafe speciale pe bat la oferta lor.
- Santurile sunt taiate din presa pentru vafe, astfel incat sa puteti introduce batul si sa inchideti in continuare presa pentru vafe.
- Presele pentru vafe din aluminiu turnat emailat, pot fi curatate cu o perie.
- Deschideti usor presa pentru vafe cu ajutorul manerului care nu se incalzeste.

- Carcasa este fabricata din otel inoxidabil 18/0, garantand o durata lunga de viata si o curatare usoara.
- Fantele de ventilatie din carcasa protejeaza comenzile impotriva supraincalzirii.
- Temperatura este reglabila continuu de la 50°C la 220°C.
- Temporizatorul poate fi configurat pana la 15 minute.



212189

## APARAT DE FACUT VAFE TIP HOT-DOG

- Este posibil sa coaceti 4 vafe pe bat in acelasi timp, fiecare lung de 255 mm (fara bat) si in forma de con alungit.
- Greutate neta: 10,5 kg.

cod	V	W	mm	lei
212189	230	1550	390x378x(H)229	929,99



212165

## APARAT DE FACUT VAFE TIP ACADEA

- Posibilitatea de a coace 4 vafe in acelasi timp, fiecare cu lungimea de 255 mm (fara bat)
- Greutate neta: 10,5 kg

cod	V	W	mm	lei
212165	230	1750	314x417x(H)229	949,99

## APARATE PENTRU VAFE

- Prese pentru vafe din fonta emailata, se pot curata cu o perie.
- Termostat pentru reglarea temperaturii
- Include furculita vafe
- Maner izolat



212103

212127

212134

### APARAT VAFE 'LIÈGE'

- Aparat vafe 'Liège', 2 modele 4x6 dreptunghiulare

cod	V	W	mm	lei
212103	230	1500	330x360x(H)561	<b>999,99</b>

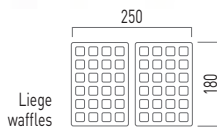

### APARAT VAFE 'BRUSSELS'

- Aparat vafe, 2 modele 3x5 dreptunghiulare

cod	V	W	mm	lei
212127	230	2200	330x520x(H)560	<b>999,99</b>

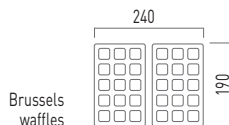

### APARAT VAFE "INIMA"

- Aparat vafe, cinci modele in forma de inima

cod	V	W	mm	lei
212134	230	2200	330x543x(H)550	<b>1079,00</b>





212028

525197

**APARAT PENTRU CLATITE - CREPIERA**

- Destinat pregatirii clatitelor
- Suprafata coacere ø400 mm din fonta cu strat ceramic.
- Caldura distribuita pe intreaga suprafata
- Include spatula de lemn
- Carcasa din otel inoxidabil
- Termostat pentru reglarea temperaturii de la 50°C pana la 300°C
- Cu protectie la supraincalzire si termostat EGO

cod	V	W	mm	lei
212028	230	3000	458x520x(H)165	<b>899,99</b>

**PALETA DIN LEMN PENTRU CLATITE.**

- Forma caracteristica - perfecta pentru intinderea aluatului pe suprafata de gatit.
- Recomandat pentru utilizarea cu aparatul de facut clatite cu codul: 212028

cod	lei
525197	<b>32,99</b>



282755

282731

**MASINA PENTRU VATA DE ZAHAR**

- Castron detasabil din otel inoxidabil, potrivit pentru masinile de spalat vase.
- Vasul este fixat de 4 cleme sigure.
- Carcasa motorului finisata cu o acoperire roz.
- Dotat cu un sertar pentru betisoare, zahar, coloranti etc.
- Intrerupatoare separate pentru pornire si elemente de incalzire, cu lampi integrate.
- Voltmetru care arata tensiunea reala.
- Dispenser de zahar inclus.
- Siguranta de suprasarcina protejeaza motorul impotriva arderii in cazul unui blocaj.
- Greutate: 11 kg.

cod	V	W	mm	lei
282731	230	1200	520x520x(H)480	<b>1199,00</b>

**CAPAC PENTRU APARATUL DE FACUT VATA DE ZAHAR**

- Oferă o protecție eficientă pentru vata de zahăr preparată
- Va permite să observați procesul de producție
- Fabricat din plastic
- Se potrivește cu mașina de vată de zahăr 282731

cod	mm	lei
282755	ø520x(H)350	<b>339,99</b>



### INCALZITOR NACHOS

- Carcasa fabricata din otel inoxidabil si sticla calita fumurie.
- Camera interioara realizata din otel inoxidabil AISI 304, cu lumina LED.
- In spate - 2 usi cu balamale, cu maner.
- Prevazuta cu o tava de colectare pentru firimituri.
- 1 intrerupator de alimentare si 1 intrerupator pentru iluminare.
- Temperatura maxima de incalzire: 58°C.
- Incarcatura max.: 35 l.
- Clasificare impermeabilitate: IPX3.

cod	V	W	mm	lei
282779	230	500	400x344x(H)525	949,99



282779



### BAIN-MARIE PENTRU SOS CU DOZATOR

- Carcasa, arc in dozator si sistem mecanic fabricat din otel inoxidabil AISI 304.
- Elementul inferior al dozatorului este fabricat din polipropilena.
- Detasabil: capac, pompa distribuitor.
- Capac prevazut cu 2 incuietori cu blocare.
- Cu senzorul de protectie la supraincalzire - porneste alarma sonora si intrerupe automat incalzirea.
- Temperatura de incalzire reglabila: pana la 90°C.
- Portia de sos distribuita: 35 ml.
- Nu poate fi spalat in masina de spalat vase.

cod	litri	V	W	mm	lei
558126	3	230	900	ø180x(H)502	1929,00



558126



### PALNIE DE CARTOFI PRAJITI SI NACHOS

- Deschidere 75 mm
- Atat pentru stangaci cat si pentru dreptaci

cod	mm	lei
642566	233x205	34,49

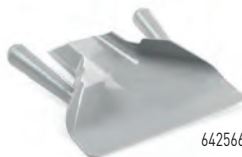

642566





282748



282762

### MASINA PENTRU POPCORN

- O masina profesionala, foarte eficienta si economica pentru productia floricelelor de porumb, destinata tuturor tipurilor de puncte de service catering.
- Cadru suport din aliaj de aluminiu
- Carcasa robusta din sticla calita si otel rosu acoperit cu pulbere
- Usa mare cu balamale din sticla acrilica pentru functionare in siguranta
- Sistem de amestecare incorporat recipient, impiedicand arderea floricelelor
- Manere din plastic care nu se incalzesc pentru a facilita golirea completa a vasului
- Clapa convenabila de indepartare a floricelelor de porumb
- Un sertar de sub camera permite indepartarea usoara a firimiturii si a boabelor ramase
- Interior iluminat

- Baza camerei incalzita
- Durata unui ciclu: aproximativ 2 minute
- Greutate: ± 25 kg



cod	culoare	V	W	mm	lei
282762	Negru	230	1500	574x420x(H)778	<b>1399,00</b>
282748	Rosu	230	1500	574x420x(H)778	<b>1399,00</b>

Compartimentul din partea de jos a aparatului permite indepartarea firimiturilor si a boabelor ramase



562017



### CUPA

cod	litri	mm	lei
562000	0.125	(L)187	<b>11,99</b>
562017	0.25	(L)250	<b>14,99</b>
562079	0.65	(L)330	<b>22,99</b>



Vezi filmul



## FANTANI DE CIOCOLATA

- Fabricat din otel inoxidabil.
- Cu functie de incalzire, incalzeste ciocolata, temperatura poate fi setata la 45°C.
- Capacitate minima de ciocolata: 1 kg.
- Capacitate maxima de ciocolata: 8,5 kg.
- Cu comutator separat pentru motor si element de incalzire.



Fantana pentru ciocolata  
cu 3 nivele



Fantana de ciocolata  
cu 5 nivele



Fantana de ciocolata  
cu 6 nivele

cod	274101	274156	274163
temperatura	45°C	110°C	150°C
capacitate minima de ciocolata	1 kg	2,5 kg	2,5 kg
capacitate maxima de ciocolata	1,5 kg	6 kg	8 kg
dimensiuni	ø210x(H)400 mm	ø330x(H)700 mm	ø370x(H)840 mm
putere	170 W/230 V	265 W/230 V	300 W/230 V
lei	<b>229,99</b>	<b>1829,00</b>	<b>2399,00</b>





Orificii mare pentru introducerea bucatilor mari de legume

Intrare mica pentru introducerea bucatilor mici de legume



5 discuri incluse,  
2 pentru felieri  
3 pentru gratar

### TAIETOR DE LEGUME PROFI LINE

- Carcasa rezistenta din aluminiu, cu finisaj neted
- Disc de taiere prevazut cu un manson de suport metalic care se uzeaza mult mai lent decat mansoanele de suport din plastic.
- 2 orificii de intrare:
  - admisie mare cu un impingator pe un brat mobil,
  - admisie mai mica cu un impingator detasat.
- Inclus in set:
  - 5 discuri de taiere pentru rezultate diferite: felii de 2 si 4 mm si aschii de 3, 4, 5 si 7 mm,
  - disc de evacuare,
  - perie speciala de curatare.
- Motorul este bine protejat impotriva supraincalzirii datorita unui ventilator de racire mare si eficient si
- Viteza: 295 RPM.
- Iesire: 100-300 kg/h.
- Diametru disc: 205 mm.

cod	V	W	mm	lei
231807	230	550	615x239x(H)580	3149,00



Vezi filmul



280096



280317



234730



### DISC FELIERE

- A se folosi la taietor legume 231807 & 231852

cod	grosime (mm)	lei
280126	4	299,99
280096	1	299,99
280102	2	299,99
280201	6	299,99
280218	8	299,99
280225	10	299,99

### DISC RAZUIRE

- A se folosi la taietor legume 231807 & 231852

cod	grosime (mm)	lei
280317	7	259,99
280294	2	259,99
280300	3	259,99
280416	4.5	259,99

### DISC TAIERE CUBURI

- A se folosi la taietor legume - heavy duty 231807 & 231852

- Trebuie folosit impreuna cu un disc de feliere

cod	grosime (mm)	lei
234747	10	449,99
234730	8	449,99



5 discuri incluse, 2 pentru  
feliere 3 pentru gratar

## TAIETOR LEGUME - HEAVY DUTY

- Potrivit pentru taierea unor cantitati mari de legume
- Orificiu mare pentru introducerea bucatilor mari, cu diametru pana la Ø 165 mm
- Orificiu mic pentru legume lungi, cum ar fi morcovii, castravetii, cu diametru pana la Ø 55 mm
- Camera taiere din aluminiu turnat, partea de jos a carcasei din otel inoxidabil
- Maner comod pentru presare
- Motor racit cu aer, 750 W = 1 hp, de inalta performanta
- Butoane de control: STOP, START (24 V)
- 2 sisteme de siguranta: aparatul se opreste cand nu mai este actionat manerul de presare si cand capacul aparatului este ridicat
- Aparatul porneste cand este apasat manerul
- Inlocuire rapida si usoara a discurilor
- 5 discuri incluse:
  - Feliere 2 mm (disc cu 3 lame)
  - Feliere 4 mm (disc cu 3 lame)
  - Raziure 3 mm
  - Raziure 4,5 mm
  - Raziure 7 mm
  - Disc evacuare
- 4 picioare anti-alunecare, din cauciuc
- Viteza: 300 rpm
- Productivitate: 100 - 350 kg/h
- Greutate 25 kg

cod	V	W	mm	lei
231852	230	750	574x250x(H)472	<b>3519,00</b>

231852

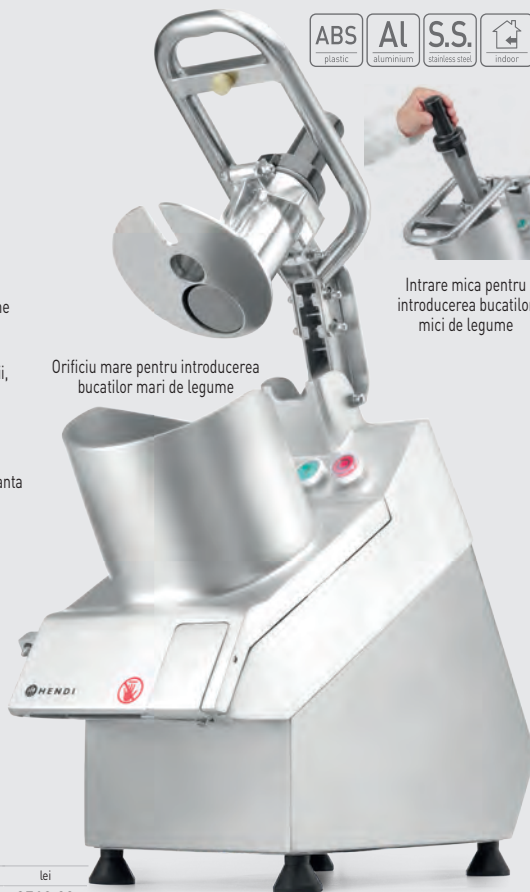

Orificiu mare pentru introducerea  
bucatiilor mari de legume

Intrare mica pentru  
introducerea bucatilor  
mici de legume



234754



280423



280621



280690

### DISC PENTRU TAIERE CARTOFI

- A se folosi la taietor legume 231807 & 231852
- Trebuie folosit impreuna cu un disc de feliere

cod	grosime (mm)	lei
234761	10	<b>369,99</b>
234754	8	<b>369,99</b>

### DISC JULIENNE

- A se folosi la taietor legume 231807 & 231852

cod	grosime (mm)	lei
280423	3	<b>369,99</b>

### DISC RAZUIRE

- A se folosi la taietor legume 231807 & 231852

cod	lei
280621	<b>289,99</b>

### SUPORT PENTRU 18 DISCURI TAIETOR LEGUME

- Capacitate: 18 discuri
- Discurile nu sunt incluse

cod	mm	lei
280690	400x250 x(H)90	<b>159,99</b>





**Protectie dubla  
impotriva**

accidentelor doua  
microintreruptoare  
de siguranta: dupa  
scoaterea capacului si/  
sau ridicarea suportului  
de golire, motorul se  
opreste automat

**Versatil - 5 viteze pentru  
o gama larga de produse**  
cu densitati diferite (legume  
radacinoase dure, rosii moi,  
banane)

**Eficienta maxima si operare confortabila**  
**Modele ULTRA cu tehnologie brushless:**

- sunt foarte eficiente deoarece lucreaza cu aceeași putere pe toată gama de viteze
- garanteaza rezultate de taiere uniforme, repetabile si reduc pierderile de produs datorita sistemului exclusiv de control al fortei
- se disting printr-o mai buna etanseitate a carcasei datorita lipsei necesitatii de ventilatie, care reduce, de asemenea, emisiile de zgomot si imbunatateste confortul de lucru

**Confort maxim pentru utilizator**  
Iesirea laterala pentru legumele feliate asigura ergonomie mai buna de lucru chiar si pe un blat de lucru mai ingust. Panou de control electronic intuitiv.

## FELIATOR ELECTRIC DE LEGUME CU PANOU GRAFIC ELECTRONIC CA-3V SI CA41V – 5 VITEZE

**sammic**

- Dispozitivul este conceput pentru taierea legumelor, in special produselor delicate, asigurandu-le forma dorita prin utilizarea diverselor tipuri de discuri de feliere, disponibile ca accesorii optionale
- Posibilitatea de a obtine felii, aschii, bastoane de diferite grosimi, cuburi si cartofi pai
- CA-41V pentru taierea capetelor mici de varza
- Nou, panou intuitiv si controlat electronic pentru o operare mai usoara cu mai multe functii importante
- Pana la 5 viteze de rotatie a cutitului, ideal pentru diferite tipuri de legume
- Motoare robuste cu tehnologie „BRUSHLESS”, mentinerea eficienta a momentului de cuplu
- Controlul fortei de taiere asigura performante de taiere identice, de cea mai inalta calitate
- Functia SENCO FORCE, care indica suprasolicitatea motorului
- Functii suplimentare de control al puterii:
  - intensitatea curentului motorului
  - temperatura modulului electronic IGBT
  - temperatura in interiorul carcasei motorului
- Fabricat din otel inoxidabil si aluminiu turnat sub presiune, se distinge prin durabilitate ridicata si adaptare la munca intensiva
- Diametru: 205 mm
- Viteza: 300-1000 rpm
- Echipat cu un alimentator mare de legume: 136 cm<sup>2</sup> sau 286 cm<sup>2</sup>
- Designul cutitului asigura taieturi repetabile
- Evacuarea laterala pentru legumele taiate permite plasarea feliatorului pe o masa ingusta
- Disc de evacuare profilat, crescand performanta dispozitivului
- Performanta de pana la 500 kg/h
- Capac usor detasabil cu clema
- Protectie dubla impotriva accidentelor: cand capacul este indepartat si/sau clema este ridicata, motorul se opreste automat

**Alimentator mare pentru legume:**  
136 cm<sup>2</sup> sau 286 cm<sup>2</sup>



**Alimentator de legume mic**



1050123



1050784



1050796

cod	diametru	capac	productivitate	V	W	mm	kg	lei
	(cm <sup>2</sup> )	(cm <sup>2</sup> )	(kg)					
1050784	CA-3V	136	do 500	230	1500	391x409x(H)552	24	<b>10999,00</b>
1050796	CA-4V	286	200-650	230	1500	391x400x(H)652	27	<b>13849,00</b>
1050123	sistem de incarcare tubular pentru legume lungi							<b>3569,00</b>





Alimentator mare  
pentru legume:  
136 cm<sup>2</sup> sau 286 cm<sup>2</sup>



Alimentator  
de legume mic



**Eficiența maximă și confort de lucru  
Modele ACTIVE cu tehnologie brushless:**

- sunt extrem de eficiente
- garantează rezultate de tăiere uniforme, repetabile și reduc pierderile de produs datorită sistemului exclusiv de control al forței
- se disting printr-o mai bună etanșeitate a carcăsei datorită lipsei necesității de ventilație, care reduce, de asemenea, emisiile de zgomot și îmbunătățește confortul de lucru
- sunt ușor de utilizat datorită noului panou de control ergonomic

**Protecție dublă împotriva  
accidentelor** două  
microîntrerupătoare de  
siguranță: după scoaterea  
capacului și/sau ridicarea  
suportului de golire, motorul  
se oprește automat

## FELIATOR ELECTRIC DE LEGUME CU PANOU ELECTRONIC DIN SERIA CA-31 SI CA-41

**sammic**

- Dispozitivul este destinat in special procesarii legumelor, garantandu-le forma dorita cu ajutorul unei game largi de discuri de feliere si grilaje disponibile ca OPTIUNE - felii, bastoane de diferite grosimi cuburi, cartofi pai
- Modele CA-41 pentru felierea capetelor mici de varza
- Panou nou, intuitiv si controlat electronic
- Fabricat din otel inoxidabil si aluminiu turnat, se distinge prin durabilitate ridicata si adaptare la munca intensiva
- Echizat cu o tava mare pentru legume: 136 cm<sup>2</sup> sau 286 cm<sup>2</sup> (in functie de model)
- Designul cutitului asigura taieturi repetabile

- lesirea laterala pentru legumele feliate permite amplasarea feliatorului pe o masa ingusta
- Productivitate: de la 150 la 650 kg/h
- Viteza: 365 rpm
- Capac usor detasabil cu presor
- Protectie dubla impotriva accidentelor: dupa scoaterea capacului si / sau ridicarea impingatorului, motorul se opreste automat
- Eficienta:
  - pentru 1050700 si 1050701 este de 150-450 kg
  - pentru 1050719 si 1050721 este de 200-650 kg



1050700



1050719



cod	model	deschidere capac (cm <sup>2</sup> )	productivitate (kg)	V	W	mm	kg	lei
1050700	CA-31 230V	136	150-450	230	550	389x405x(H)544	21	<b>5449,00</b>
1050701	CA-31 400V	136	150-450	400	550	389x405x(H)544	21	<b>6059,00</b>
1050719	CA-41 230V	286	200-650	230	550	391x396x(H)653	24	<b>9849,00</b>
1050721	CA-41 400V	286	200-650	400	550	391x396x(H)653	24	<b>9849,00</b>





**Productivitate mai mare**  
2 viteze si un alimentator foarte eficient  
pentru incarcarea unor cantitati mari  
de produse



## FELIATOR DE LEGUME ELECTRIC PENTRU LEGUME CU CAPACITATE MARE, CU PANOU ELECTRONIC CA-62 SAMMIC

 **sammic**

- Dispozitivul este conceput pentru procesarea legumelor, garantandu-le forma dorita cu ajutorul unei game largi de discuri de feliere, barbierit, bare, cuburi si cartofi prajiti
- Fabricat din otel inoxidabil si aluminiu turnat sub presiune, se remarca cu durabilitate ridicata si adaptare la munca intensiva
- Dispozitivul este echipat cu o tava mare pentru legume si o tava laterala priza pentru produsul finit
- Designul cutitului asigura taieturi repetabile
- Panou nou usor de utilizat, impermeabil, controlat electronic
- Doua viteze de lucru:
  - 365 rpm - pentru taiere de precizie
  - 730 rpm - pentru performante maxime
- Productivitate: 500/1000 kg/h
- Deschidere de incarcare: 273 cm<sup>2</sup>
- Diametru cadran: 205 mm
- Maneta si capac usor demontabile pentru o curatare usoara
- Sistem de siguranta precis inainte de a deschide capacul
- Greutate: 29,5 kg



cod	model	diametru capac (cm <sup>2</sup> )	productivitate (kg)	V	W	mm	kg	lei
1050738	CA 62	273	500-1000	230	750	430x420x(H)810	29,5	16249,00





cod		recomandat pentru	numarul de cutite	lei
1010215	Disc feliere FC-1 + 1 mm	Castraveti, morcovi, si chipsuri de cartofi	3	517,99
1010220	Disc feliere FC-2 + 2 mm	Castraveti, morcovi, ceapa, si chipsuri de cartofi	2	517,99
1010224	Disc feliere FC-3D 3 mm		2	517,99
1010227	Disc feliere FC-6D 6 mm		2	517,99
1010409	Disc feliere FC-8D 8 mm		1	517,99
1010410	Disc feliere FC-10D 10 mm	Castraveti, morcovi, ceapa, chipsuri de cartofi, varza si altele	1	517,99
1010411	Disc feliere FC-14D 14 mm		1	569,99
1010252	Disc feliere FC-20 + 20 mm		1	549,99
1010247	Disc feliere FC-20 + 25 mm		1	549,99
1010406	Disc feliere FCC-2 + 2 mm	Lama curbata permite taierea precisa a produselor delicate:	2	517,99
1010403	Disc feliere FCC-3 + 3 mm	rosii, portocale, banane, lamai etc.	1	517,99
1010404	Disc feliere FCC-5 + 5 mm		1	517,99
1010295	Disc feliere ondulata FCO-2 + 2 mm	Lama canelata iti permite		565,99
1010300	Disc feliere ondulata FCO-3 + 3 mm	sa obtii felii ondulate de castraveti, morcovi, cartofi etc.	2	565,99
1010408	Disc feliere ondulata FCO-6 + 6 mm		2	565,99



cod		recomandat pentru	lei
1010350	Disc cartofi prajiti FFC-8 + 8 mm	In combinatie cu discul FC-8, va permite sa obtineti cartofi pai	523,99
1010355	Disc cartofi prajiti FFC-10 + 10 mm	In combinatie cu discul FC-10, va permite sa obtineti cartofi pai	523,99
1010364	Disc cuburi FMC-14D 14x14 mm	In combinatie cu discul FC-14D, va permite sa obtineti cuburi de 14x14x14 mm	565,99
1010375	Disc cuburi FMC-20 + 20x20 mm	In combinatie cu discul FC-20, va permite sa obtineti cuburi de 20x20x20 mm	565,99
1010380	Disc cuburi FMC-25 + 25x25 mm	In combinatie cu discul FC-25, va permite sa obtineti cuburi de 25x25x25 mm	565,99



cod		recomandat pentru	numarul de cutite	lei
1010205	Disc Julienne FCE-2 + 2x2 mm		2	594,99
1010210	Disc Julienne FCE-4 + 4x4 mm	Taiere „Julienne”.		594,99
1010405	Disc Julienne FCE-8 + 8x8 mm	Telina, patrunjel, morcovi etc.	1	785,99



cod		recomandat pentru	lei
1010390	Set de piure de cartofi	Pentru piure de cartofi, a se folosi doar cu discul pentru felii	746,99



cod		recomandat pentru	lei
1010320	Disc maruntire SH-2 2 mm	Disc maruntire legume, branza pizza, nuci, migdale	362,99
1010315	Disc maruntire SH-3 3 mm		324,99
1010322	Disc maruntire SH-4 4 mm		324,99
1010324	Disc maruntire SH-6 6 mm		324,99
1010326	Disc maruntire SH-7 7 mm		324,99



cod		recomandat pentru	lei
1010318	Disc maruntire SH-1 1 mm	Disc maruntire paine, branza tare, ciocolata, etc	362,99
1010328	Disc maruntire SH-8 8 mm		362,99



cod		recomandat pentru	lei
1010362	Disc cuburi FMC-8D 8x8 mm	In combinatie cu discul FC-8D, va permite sa obtineti cuburi de 8x8x8	565,99
1010363	Disc cuburi FMC-10D 10x10 mm	In combinatie cu discul FC-10D, va permite sa obtineti cuburi de 10x10x10	523,99



cod		lei
1010361	Set spalare discuri FMC-8	506,99
1010366	Set spalare discuri FMC-10	506,99
1010359	Suport pentru set spalare QC-8 si QC-10	309,99



cod		recomandat pentru	lei
1010320	Disc maruntire SH-2 2 mm	Disc maruntire legume, branza pizza, nuci, migdale	362,99
1010315	Disc maruntire SH-3 3 mm		324,99
1010322	Disc maruntire SH-4 4 mm		324,99
1010324	Disc maruntire SH-6 6 mm		324,99
1010326	Disc maruntire SH-7 7 mm		324,99

Disc maruntire paine, branza tare, ciocolata, etc



cod		recomandat pentru	lei
1010362	Disc cuburi FMC-8D 8x8 mm	In combinatie cu discul FC-8D, va permite sa obtineti cuburi de 8x8x8	565,99
1010363	Disc cuburi FMC-10D 10x10 mm	In combinatie cu discul FC-10D, va permite sa obtineti cuburi de 10x10x10	523,99



1010204

### DISC SI SUPTOR PENTRU GRATAR

- Ideal pentru depozitarea discurilor si gratarelor pentru 10 discuri

cod		lei
1010204		248,99

### SUPTOR MOBIL PENTRU FELIATOR

- Baza va permite sa asezati dispozitivul la inaltimea optima pentru lucru si sa reglati recipientul GN direct la iesirea tocatului din otel inoxidabil echipat cu 2 roti pentru transport facil

cod		mm	lei
1050063		666x686x(H)400	1599,00



1050063



## FELIATOR ELECTRIC DE LEGUME COMPACT LINE



- Discurile de taiere proiectate cu o precizie exceptionala asigura o taiere foarte precisa
  - Constructia robusta realizata din materiale de cea mai inalta calitate aprobate pentru contactul cu alimentele
  - Usor de utilizat datorita noului panou de control ergonomic
  - Greutate redusa si design compact - feliatorul cantareste mai putin si ocupa mai putin spatiu
  - Carcasa din fibra de sticla - polimer armat
  - Rezistenta ridicata la apa - carcasa este lipsita de orificii de ventilatie
  - Functionare silentioasa - confort ridicat pentru utilizator
  - Gama larga de aplicatii - reglare a vitezei in 5 trepte
- Model 1050962 pentru produse cu diferite structuri (legume radacinoase tari si rosii moi, banane)
  - Pana la 35 de tipuri diferite de feliere - datorita utilizarii unei game largi de discuri si grile (se comanda separat)
  - Tehnologia fara perii [modelul 1050962] garanteaza rezultate de taiere uniforme, repetabile si reduce pierderile de produs datorita sistemului exclusiv de control al presiunii (Sistem de control al fortei)
  - Protectie dubla impotriva accidentelor - doua microintreruptoare de siguranta: dupa indepartarea capacului si/sau ridicarea clemei, motorul se opreste automat

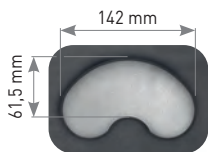

1050940



1050962



cod	model	deschidere alimentare (cm <sup>2</sup> )	productivitate (kg)	vitez (rpm)	V	W	mm	kg	lei
1050940	CA-21	89	50-350	1500	230	800	378x309(H)533	15,3	<b>4459,00</b>
1050962	CA-2V	89	50-350	300-1000	230	1100	378x309(H)533	13	<b>8289,00</b>

## ACCESORII

cod		lei
2059762	Atasament - taietor, pentru gama Compact	<b>1359,00</b>
2059750	Disc neted pentru taietoare Compact Line si dispozitive multifunctionale Recomandat in principal pentru tocarea carnii crude si a produselor fibroase	<b>771,99</b>
2059752	Disc perforat pentru taietoare Compact Line si dispozitive multifunctionale Recomandat in principal pentru baterea albusurilor si prepararea sosurilor	<b>817,99</b>
2059748	Disc zimtat pentru taietoare Compact Line si dispozitive multifunctionale Recomandat in principal pentru framantarea aluatului si uz general	<b>817,99</b>



2059762



2059752

1010204



## DISC SI SUPORT PENTRU GRATAR

- Ideal pentru depozitarea discurilor si gratarelor pentru 10 discuri

code	lei
1010204	<b>248,99</b>

## DISCURI DE FELIERE COMPACT LINE



cod		recomandat pentru	lei
1010530	Disc feliere FCS-1 1 mm	Castraveti, morcovi si chipsuri de cartofi	394,99
1010532	Disc feliere FCS-2 2 mm		394,99
1010534	Disc feliere FCS-3 3 mm	Castraveti, morcovi, ceapa si chipsuri de cartofi	394,99
1010536	Disc feliere FCS-4 4 mm		394,99
1010538	Disc feliere FCS-5 5 mm		394,99
1010540	Disc feliere FCS-6 6 mm	Castraveti, morcovi, ceapa, chipsuri de cartofi,	394,99
1010570	Disc feliere FCS-8 8 mm	varza alba si multe altele	429,99
1010572	Disc feliere FCS-10 10 mm		429,99
1010574	Disc feliere FCS-12 12 mm		429,99
1010546	Disc feliere ondulata FCS-2 2 mm	Lama canelata produce felii ondulate de castraveti, morcovi, cartofi etc.	379,99



cod		recomandat pentru	lei
1010590	Disc cartofi prajiti FFS-8 8 mm	In combinatie cu discul FCS-8, va permite sa obtineti cartofi prajiti	560,99
1010592	Disc cartofi prajiti FFS-10 10 mm	In combinatie cu discul FCS-10, va permite sa obtineti cartofi prajiti	560,99
1010580	Disc cuburi FMS-8 8x8 mm	In combinatie cu discul FCS-8, va permite obtinerea unor cuburi de 8x8x8 mm	560,99
1010582	Disc cuburi FMS-10 10x10 mm	In combinatie cu discul FCS-10, permite obtinerea unor cuburi de 10x10x10 mm	560,99
1010584	Disc cuburi FMS-12 12x12 mm	In combinatie cu discul FCS-12, permite obtinerea unor cuburi de 12x12x12 mm	560,99



cod		recomandat pentru	lei
1010514	Set piure de cartofi - disc fin SHSF	Pentru piure de cartofi,	308,99
1010516	Set de piure de cartofi - disc grosier SHSG	sa se folosi doar cu discul de feliere	308,99



cod		recomandat pentru	lei
1010500	Disc maruntire SHS-2 2 mm		308,99
1010502	Disc maruntire SHS-3 3 mm		308,99
1010504	Disc maruntire SHS-4 4 mm	Disc maruntire legume, branza pizza, nuci, migdale	308,99
1010506	Disc maruntire SHS-7 7 mm		308,99



cod		recomandat pentru	lei
1010550	Disc Julienne FCES 2x2 mm		517,99
1010552	Disc Julienne FCES 2x4 mm		517,99
1010554	Disc Julienne FCES 2x6 mm		517,99
1010556	Disc Julienne FCES 4x4 mm	Taiere „Julienne”. Telina, patrunjel, morcovi etc.	517,99
1010558	Disc Julienne FCES 6x6 mm		517,99
1010560	Disc Julienne FCES 8x8 mm		517,99





Posibilitatea de a programa timpul si butonul de functionare, crescand astfel eficienta si productivitatea. Rotatie inversa pentru mixarea produselor in functie de nevoi, utilizarea lamelor netede sau a lamelor perforate optionale.

Siguranta  
Doua comutatoare de siguranta in zona vasului si a capacului de protectie - atunci cand capacul si/sau vasul sunt indepartate, motorul se opreste automat

Constructie robusta din otel inoxidabil si aluminiu pentru functionare intensiva si fara intreruperi, care asigura o rezistenta ridicata la conditiile de lucru



## TOCATOARE SI EMULSIFICATOARE

 **sammic**

- Dispozitivul este conceput pentru macinarea, tocarea, si amestecarea tuturor tipurilor de produse, precum legume si ierburi, carne cruda si gatita, peste, fructe, nuci, cuburi de gheata si framantarea tuturor tipurilor de aluat
- Perfect pentru prepararea de mousse, piureuri, sosuri, supe si carne tocata pentru chiftele sau tartar, piure de cartofi, legume si chiar fructe, unt, de exemplu, cu adaos de ierburi, maioneza si chiar pentru framantare aluat sau zahar pudra si masa de migdale
- Emulgatoarele sunt concepute special pentru lucrul cu lichide
- In plus, emulgatorii sunt echipati cu o spatula manuala, care permite un amestec si mai omogen
- Rezervor detasabil din otel inoxidabil (5,5 sau 8 litri in functie de model) cu capac din policarbonat si deschidere pentru adaugarea de ingrediente in timp ce functionarea dispozitivului
- Sisteme de siguranta care nu permit pornirea rotatiei motorului atunci cand emulsificatorul sau modulul taietor nu este montat pe blocul motorului sau cand este instalat incorect
- Microswitch de siguranta suplimentar care blocheaza rotatia cutit cu capacul recipientului indepartat sau instalat necorespunzator
- Este inclus un cutit zimat
- Blocul motorului este fabricat din aliaj de aluminiu de inalta clasa

- Etanseitatea ridicata a carcasei previne inundarea motorului
- Emulsificatoarele sunt echipate cu un panou grafic modern, electronic, cu multe functii utile si informatii despre functionarea dispozitivului:
- Functia de recunoastere a unui modul instalat corect
- Puteti alege pana la 10 viteze de rotatie a cutitului pentru diferite tipuri ingrediente si feluri de mancare
- Functia de rotatie inversa ideala, de exemplu, atunci cand scoateti produs finit
- Functia de impuls utila atunci cand tocati delicat produse pentru a nu le macina complet
- Indicator grafic de viteza cu indicarea numarului de viteza si rotatii pe minut
- Capacitatea de a seta timpul de lucru
- Motoare puternice cu tehnologie „BRUSHLESS” pentru o intretinere eficienta a cuplului in fiecare din cele 10 intervale de viteza
- Functii suplimentare de control al fortei: permite observatii pana la 4 parametri de functionare a dispozitivului:
  - curent motor
  - puterea motorului la un moment dat
  - temperatura in modulul electronic al IGBT
  - temperatura din interiorul carcasei motorului.



1050834



1050853



cod	tip	container (l)	nr. viteze	viteza cutit (rpm)	V	W	mm	container (mm)	greutate - emulsificator (kg)	greutate - tocator (kg)	lei
1050834	KE-5V	5,5	10	300-3000	230	1500	286x387x(H)487	Ø240x(H)150	26,5	18	<b>9299,00</b>
1050853	KE-8V	8	10	300-3000	230	1500	286x387x(H)517	Ø240x(H)199	27,6	19	<b>12249,00</b>

## ACCESORII SAMMIC

cod	lei
2053058	<b>817,99</b>
Cutit neted pentru tocatulor K-52, emulsificatorul KE-5V si masinile multifunctionale CK-35V si CK-45V. Recomandat in principal pentru tocarea carni crude si a produselor fibroase.	
2053935	<b>1299,00</b>
Cutit neted pentru tocatulor K-82, emulsificatorul KE-8V si masinile multifunctionale CK-38V si CK-48V. Recomandat in principal pentru tocarea carni crude si a produselor fibroase.	
2053063	<b>743,99</b>
Cutit perforat pentru tocatulor K-52, emulsificatorul KE-5V si masini multifunctionale CK-35V si CK-45V. Recomandat in principal pentru baterea albusurilor si prepararea sosurilor	
2053940	<b>1199,00</b>
Cutit perforat pentru tocatulor K-82, emulsificatorul KE-8V si masini multifunctionale CK-38V si CK-48V. Recomandat in principal pentru baterea albusurilor si prepararea sosurilor	
2053091	<b>868,99</b>
Cutit zimat pentru tocatulor K-52, emulsificatorul KE-5V si masini multifunctionale CK-35V si CK-45V. Recomandat in principal pentru framantarea aluatului si uz general	
2053930	<b>1399,00</b>
Cutit zimat pentru tocatulor K-82, emulsificatorul KE-8V si masini multifunctionale CK-38V si CK-48V. Recomandat in principal pentru framantarea aluatului si uz general	
2059417	<b>329,99</b>
Racleta pentru emulsificatorul KE-5V si masini multifunctionale CK-35V si CK-45V	
2053960	<b>365,99</b>
Racleta pentru emulsificatorul KE-8V si masini multifunctionale CK-38V si CK-48V	





## TOCATOARE SI EMULSIFICATOARE SAMMIC COMPACT LINE

 **sammic**

- Aparatul este destinat pentru macinare, tocare si amestecarea diverselor produse si pentru framantarea aluatului
- Emulsificator conceput special pentru lucrul cu lichide
- Recipient detasabil din otel inoxidabil (4,4 l) cu capac din policarbonat si o deschidere pentru adaugarea ingredientelor in timp ce dispozitivul functioneaza
- Emulsificator echipat cu un panou grafic modern, electronic (model 1051000) cu multe functii si informatii utile despre functionarea dispozitivului
- Aplicatie larga - reglare a vitezei in 5 trepte (model 1051000) pentru produse cu texturi diferite (dure: radacinoase si moi: rosii, banane). Programe speciale: macinare grosiera si fina, cronometru

- Avertizare de suprasarcina - Controlul fortei - alarma vizuala si sonora
- Dubla protectie impotriva accidentelor - microintreruptoare de siguranta la vas si la capac, sistem de avertizare despre erori
- O structura solida realizata din materiale de cea mai inalta calitate aprobate pentru contactul cu alimentele
- Usor de utilizat datorita noului panou de control ergonomic
- Greutate reduca si design compact
- Carcasa din fibra de sticla - polimer armat
- Rezistenta ridicata la apa - carcasa este lipsita de orificii de ventilatie
- Functionare silentioasa - confort ridicat pentru utilizator
- Bolul taietorului este echipat cu manere ergonomice



1050980



1051000



2059762



2059752



cod	model	tip	recipient (l)	viteza (rpm)	V	W	mm	motor	greutate (kg)	lei
1050980	K-41	tocator	4,4	1500	230	800	252x309x(H)434	asincron	14,2	<b>4819,00</b>
1051000	KE-4V	tocator-emulsificator	4,4	300-3000	230	1100	252x309x(H)434	fara perii	11,9	<b>7649,00</b>

### ACCESORII

cod	lei	
2059760	Cap suplimentar pentru feliere 1050940 si 1050962 sau taietor 1050980 si 1051000	<b>1719,00</b>
2059750	Cutit neted pentru taietoare Compact Line si dispozitive multifunctionale Recomandat in principal pentru tocarea carnilor crude si a produselor fibroase	<b>771,99</b>
2059752	Cutit perforat pentru taietoare Compact Line si dispozitive multifunctionale Recomandat in principal pentru baterea albusurilor si prepararea sosurilor	<b>817,99</b>
2059748	Cutit zimtat pentru taietoare Compact Line si dispozitive multifunctionale Recomandat in principal pentru framantarea aluatului si uz general	<b>817,99</b>



**CUTTER SAMMIC CU 2 VITEZE**

- Echipament extrem de eficient pentru felierea, tocarea, amestecarea si zdrobirea produselor
- Constructia robusta din otel inoxidabil si aluminiu asigura
- O durabilitate ridicata si rezistenta la factorii externi
- Panoul de control clar si intuitiv face ca masina de taiat sa fie extrem de usor de utilizat
- Rezervorul detasabil din otel inoxidabil este prevazut cu un capac din policarbonat cu o deschidere pentru a permite adaugarea de ingrediente in timp ce masina este in functiune

- Sistemele de siguranta impiedica pornirea motorului, in cazul in care modulul de taiere nu este montat pe blocul motor sau daca acesta este montat incorect
- Un micro-interruptor de siguranta suplimentar blocheaza rotatia dispozitivului de taiere in cazul in care capacul containerului este indepartat sau montat incorect
- Control al vitezei in 2 trepte: 1500 si 3000 rpm
- Lama zimtata inclusa



1050832



1050850

cod	tip	container (l)	nr. viteze	viteza cutit (rpm)	V	W	mm	container (mm)	greutate - emulsificator (kg)	greutate - tocator (kg)	lei
1050832	K-52	5,5	2	1500 si 3000	400	1500	286x387x(H)439	Ø240x(H)150	29,7	18	<b>8249,00</b>
1050850	K-82	8	2	1500 si 3000	400	1500	286x387x(H)473	Ø240x(H)199	30,8	18,9	<b>7999,00</b>

**ACCESORII SAMMIC**

cod	lei
2053058 Cutit neted pentru tocatorul K-52, emulsificatorul KE-5V si masinile multifunctionale CK-35V si CK-45V. Recomandat in principal pentru tocarea carnii crude si a produselor fibroase.	<b>817,99</b>
2053935 Cutit neted pentru tocatorul K-82, emulsificatorul KE-8V si masinile multifunctionale CK-38V si CK-48V. Recomandat in principal pentru tocarea carnii crude si a produselor fibroase.	<b>1299,00</b>
2053063 Cutit perforat pentru tocatorul K-52, emulsificatorul KE-5V si masini multifunctionale CK-35V si CK-45V. Recomandat in principal pentru baterea albusurilor si prepararea sosurilor	<b>743,99</b>
2053940 Cutit perforat pentru tocatorul K-82, emulsificatorul KE-8V si masini multifunctionale CK-38V si CK-48V. Recomandat in principal pentru baterea albusurilor si prepararea sosurilor	<b>1199,00</b>
2053091 Cutit zimtat pentru tocatorul K-52, emulsificatorul KE-5V si masini multifunctionale CK-35V si CK-45V. Recomandat in principal pentru framantarea aluatului si uz general	<b>868,99</b>
2053930 Cutit zimtat pentru tocatorul K-82, emulsificatorul KE-8V si masini multifunctionale CK-38V si CK-48V. Recomandat in principal pentru framantarea aluatului si uz general	<b>1399,00</b>
2059417 Racleta pentru emulsificatorul KE-5V si masini multifunctionale CK-35V si CK-45V	<b>329,99</b>
2053960 Racleta pentru emulsificatorul KE-8V si masini multifunctionale CK-38V si CK-48V	<b>365,99</b>



## APARAT MULTIFUNCTIONAL SAMMIC COMPACT LINE

**sammic**

- Tocator pentru legume, in special produse delicate, si modelarea acestora in forma dorita folosind o gama larga de discuri si lame disponibile optional
- Discurile de taiere proiectate cu o precizie exceptionala asigura o taiere foarte precisa
- Structura solida realizata din materiale de cea mai inalta calitate aprobate pentru contactul cu alimentele
- Sunt usor de utilizat datorita noului panou de control ergonomic
- Greutate redusa si design compact
- Carcasa din fibra de sticla - polimer armat
- Rezistenta ridicata la apa - carcasa este lipsita de orificii de ventilatie
- Functionare silentioasa - confort ridicat pentru utilizator
- Gama larga de aplicatii - control al vitezei in 5 trepte (model 1050962) pentru produse cu diferite structuri (legume radacinoase tari si rosii moi, banane)
- Tehnologia fara perii (modelul 1050962) garanteaza rezultate de taiere uniforme, repetabile si reduce pierderile de produs datorita sistemului exclusiv de control al presiunii (Sistem de control al fortei)

- Protectie dubla impotriva accidentelor - doua microintreruptoare de siguranta: dupa indepartarea capacului si/sau ridicarea clemei, motorul se opreste automat
- Tava mare pentru legume: 89 cm<sup>2</sup>
- Lesire laterala pentru produsul finit care permite setarea masinii pe o zona mica de lucru. 1 sau 5 viteze tocator: 1500 sau 300 pana la 1000 rpm (in functie de model)
- Disc de evacuare profilat care maresta eficienta dispozitivului
- Productivitate: 50-350 kg/ora
- Maneta si capacul usor demontabile
- Recipient emulsificator cu o capacitate 4,4 l destinat macinarii, tocatului, macinarii si amestecarii produselor precum si framantarii tuturor tipurilor de aluat
- 1 sau 10 viteze de la 300 pana la 1000 rpm (in functie de model)
- Functie puls (model 1050900) utila la tocarea produselor delicate pentru a nu le macina intr-o pulpa (numai pentru modulul emulgator)
- Pana la 35 de tipuri diferite de taieturi - datorita utilizarii unei game largi de discuri si grile (se comanda separat)



cod	productivitate (kg/h)	deschidere alimentara (cm <sup>2</sup> )	recipient (l)	V	W	dimensiunile feliatorului (mm)	dimensiunile taietorului (mm)	greutatea feliatorului (kg)	greutatea taietorului (kg)	lei
1050900	50-350	89	4,4	230	1500	378x309(H)533	252x309x(H)434	15,3	14,2	<b>6569,00</b>
1050922	50-350	89	4,4	230	1500	378x309(H)533	252x309x(H)434	13	11,9	<b>10349,00</b>

### ACCESORII

cod	lei
2059762	Atasament - taietor, pentru gama Compact Range <b>1359,00</b>
2059750	Cuit neted pentru taietoare si dispozitive multifunctionale Compact Line Recomandat in principal pentru tocarea carni crude si a produselor fibroase <b>771,99</b>
2059752	Cuit perforat pentru taietoare si dispozitive multifunctionale Compact Line Recomandat in principal pentru baterea albusurilor si prepararea sosurilor <b>817,99</b>
2059748	Cuit zimtat pentru freze si dispozitive multifunctionale Compact Line Recomandat in principal pentru framantare si uz general <b>817,99</b>





#### Siguranta

Doua microintreruptoare de siguranta in pozitia vasului si a capacului - atunci cand capacul si/sau vasul sunt indepartate, motorul se opreste automat

**Aplicatia Wi-Fi** - reglare a vitezei in 5 pasi pentru produse cu diverse structuri (legume radacinoase tari si rosii moi, banane)

## MASINA MULTIFUNCTIONALA CU PANOU GRAFIC ELECTRONIC DIN SERIA CK SAMMIC

**sammic**

Echibat cu:

- Capete de taiere legume pentru taierea legumelor, in special a produselor delicate, si modelarea acestora in forma dorita folosind o gama larga de discuri si grile disponibile ca OPTIUNE
- Capul este din aluminiu turnat sub presiune, se distinge printr-unul inalt durabilitate si adaptare la munca intensiva
- Tava mare pentru legume: 136 cm<sup>2</sup> sau 286 cm<sup>2</sup>
- Iesire laterala pentru produsul finit care va permite sa setati masina pe o suprafata mica de lucru
- Pana la 5 viteze de taiere de la 300 la 1000 rpm
- Disc de evacuare profilat care creste eficienta dispozitivului
- Capacitate: de la 100 la 650 kg/ora. (in functie de model)
- Deschidere mare cu o suprafata de 286 cm<sup>2</sup>
- Maneta si capac usor demontabile
- Rezervor de emulgator conceput pentru zdrobire, tocare, macinare si amestecare a unei varietati de produse alimentare, precum legume si ierburi, carne cruda si gatita, peste, fructe, nuci, cuburi de gheata si framantarea tuturor tipurilor de aluat
- Perfect pentru prepararea de mousse, piureuri, sosuri, supe si carne tocata in chiftele sau tartare, piure de cartofi, legume si fructe, unt, de exemplu, cu ierburi, maioneza si chiar pentru

- prepararea de aluat sau zahar pudra si masa de migdale
- 10 viteze disponibile de la 300 la 3000 rpm
- Motoare puternice cu tehnologie „BRUSHLESS” pentru o intretinere eficienta cuplu in fiecare din cele 10 intervale de viteza
- Functia de rotatie inversa (numai pentru modulul emulgator) perfecta de ex. la scoaterea produsului finit
- Functia de impuls utila atunci cand tocaci delicat produse astfel incat sa nu fie macinate intr-o pasta (numai pentru modulul emulgator)
- Etanseitatea ridicata a carcasei previne inundarea motorului
- Rezervor detasabil din otel inoxidabil (5,5 sau 8 litri in functie de model) cu capac din policarbonat cu deschidere, permitandu-va sa adaugati ingrediente in timp ce dispozitivul functioneaza
- Este inclus un cutit zimtat
- O spatula pentru amestecarea suplimentara si indepartarea alimentelor tocate de pe peretii rezervorului
- Bloc motor cu panou grafic electronic nou
- Nivel de zgomot: <70 dB
- Diametru cadran: 205 mm



cod	model	productivitate (kg/h)	deschidere capac (cm <sup>2</sup> )	emulsificator (l)	V	W	dimensiune tocator (mm)	dimensiune cutit (mm)	greutate - emulsificator (kg)	greutate - tocator (kg)	lei
1050752	CK-35V	100-450	136	5,5	230	1500	391x409x(H)552	286x387x(H)487	26,5	18	12799,00
1050808	CK-38V	100-450	136	8	230	1500	391x409x(H)552	286x387x(H)517	27,6	19	16149,00
1050769	CK-45V	200-650	286	5,5	230	1500	391x400x(H)652	286x387x(H)487	29,7	18	16899,00
1050821	CK-48V	200-650	286	8	230	1500	391x400x(H)652	286x387x(H)517	30,8	18,9	18499,00





## TOCATOR DE CARNE CU CAPACITATE MARE DE PANA LA 280 KG/ORA

- O solutie optima pentru clientii care doresc controleze atent rețetele pentru carne tocata.
- Unitatea de actionare trebuie comandata separat, iar tava de incarcare si unitatea de taiere, sunt disponibile doua variante: „ENTERPRISE” si „UNGER”. Ambele unitati sunt fabricate din otel inoxidabil si sunt prevazute standard cu surub si sita cu orificii de  $\phi 6$  mm. Totusi, cutitele pot diferi, avand muchii taioase pe una sau doua parti.



1050210

## MASINA DE TOCAT CARNE DE INALTA EFICIENTA PS-22

- Priza pentru asamblarea rapida si usoara a tavii de incarcare cu ajutorul unitatii de taiere
- Alimentator detasabil din otel inoxidabil START si STOP
- Diametrul gatului de incarcare: corp impingator din polipropilena 60 mm fabricat din otel inoxidabil
- Echipat cu un cablu de 1,3m, cu imbapantare; nivel zgomot: sub 70 dB
- Greutate: 30 kg



code	mm	V	W	lei
1050210	310x440x(H)480	230	740	<b>7209,00</b>

## SISTEM DE TAIERE PENTRU MASINA DE TOCAT CARNE PS-22

- Fabricat din elemente din otel inoxidabil ale unitatii de taiere:
  - Surub
  - Cutit de taiere pe o parte
  - Sita cu orificii de  $\phi 6$  mm, diametru total de 82 mm
  - Mecanismul de actionare si alte filtre trebuie comandate separat

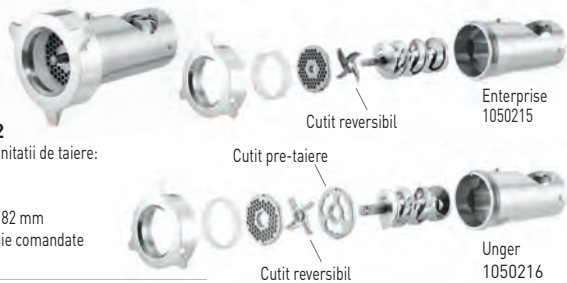

cod	model		mm	greutate (kg)	lei
1050215	Enterprise	o muchie taioasa	200x200x(H)245	6,5	<b>2909,00</b>
1050216	Unger	doua muchii taioase	200x200x(H)245	6,7	<b>3099,00</b>

## FILTRU PENTRU UN TOCATOR DE CARNE DE EFICIENTA RIDICATA

- Fabricat din otel inoxidabil.
- Poate fi curatat in masina de spalat vase.
- Se potriveste cu unitatea de taiere Enterprise cu un set de taiere (1050215).

cod	potrivit pentru	diametru oficii (mm)	lei
282021	1050216	$\phi 6$	<b>124,99</b>
282014	1050216	$\phi 8$	<b>124,99</b>
282038	1050216	$\phi 4,5$	<b>124,99</b>
282045	1050216	$\phi 3$	<b>144,99</b>



2051525





5410000

### STORCATOARE SAMMIC

- Motor racit cu aer pentru functionare continua si eficienta
- Viteza controlata electronic pana la 6.300 rpm
- Container pentru pulpa pentru a preveni infundarea
- Sistemul automat de evacuare a pulpei ajuta la prelungirea timpului de operare
- Capacitate recipient pulpa: 3 1/4 l
- Comutatorul turbo care maresc viteza de rotatie permite si curatarea cosului si echilibreaza eventualele vibratii
- Usurinta in utilizare si curatare
- Asamblarea si dezasamblarea simpla si intuitiva a elementelor individuale
- Blocare de siguranta care dezactiveaza rotirea cu capacul indepartat
- Corp motor din otel

cod	V	W	mm	lei
5410000	230	240	310x205x(H)360	2569,00





## MASINI DE TOCAT PROFI LINE

- Echipament profesional de inalta calitate conceput pentru tocarea tuturor tipurilor de carne fara piele si fara os
- Structura realizata in intregime din otel inoxidabil lustruit, de inalta calitate
- Palnie detasabila din otel chirurgical (304 18/10).
- Demontarea facila a palniei si a tuturor pieselor interne pentru o curatare usoara
- Protectie motor impotriva supraincalzirii
- Viteza de rotatie 165 rpm
- Masina cu functie REVERSE in caz de infundare a palniei
- Buton de resetare care protejeaza dispozitivul impotriva supraincalzirii
- Tava de incarcare este realizata din otel inoxidabil.
- Standard IPX1
- Prindere confortabila pe partea superioara a corpului pentru manevrare usoara
- Picioare antiderapante
- Pachetul include:
  - 2 discuri de tocat din otel inoxidabil cu gauri de 6 si 8 mm (5 si 8 mm la modelul 210765)
  - Cutit si vierme din otel inoxidabil
- Tub umplere din polipropilena
- Impingator de carne din polietilena
- Nu se recomanda utilizare continua (dupa 45 de minute de functionare opriti pentru a se raci)

PRODUCTIVITATE  
pana la  
**250 kg/h**



## MASINA DE TOCAT PROFI LINE 8

- Motor puternic de pana la 550 W
- Putere: pana la 80 kg / h
- Diametrul discului ø62 mm
- Greutate: 20,5 kg

cod	V	W	mm	lei
210765	230	300	250x370 x(H)490	<b>1779,00</b>

## MASINA DE TOCAT PROFI LINE 12

- Motor puternic de pana la 735 W
- Rezultat: pana la 150 kg / h
- Diametrul discului ø69,8 mm
- Greutate: 24,5 kg

cod	V	W	mm	lei
210772	230	550	264x420 x(H)548	<b>2199,00</b>

## MASINA DE TOCAT CARNE PROFI LINE 22

- Un motor puternic cu o putere instantanea de pana la 1100 W.
- Productivitate: pana la 250 kg / h.
- Diametrul discului: ø82 mm.
- Greutate: 31 kg.

cod	V	W	mm	lei
210789	230	900	305x490 x(H)607	<b>2929,00</b>



### SITA

cod	potrivit pentru	mm	lei
210413	210765	ø5	<b>89,99</b>
210420	210765	ø8	<b>89,99</b>
210451	210772	ø6	<b>89,99</b>
210468	210772	ø8	<b>89,99</b>
210499	210789	ø6	<b>109,99</b>
210505	210789	ø8	<b>109,99</b>



### CUTIT

cod	potrivit pentru	lei
210406	210765	<b>69,99</b>
210444	210772	<b>89,99</b>
210482	210789	<b>79,99</b>



### MELC

cod	potrivit pentru	lei
210390	210765	<b>249,99</b>
210437	210772	<b>249,99</b>
210475	210789	<b>299,99</b>

## MASINA DE TOCAT CARNE PROFI LINE 12

- Carcasa, palnia si vasul pentru carne sunt confectionate din otel inoxidabil
- Melc fabricat din otel inoxidabil
- Dispozitiv de impingere din polietilena
- Transmisie in ulei, silentioasa
- Diametrul sitei de 70 mm cu orificii de  $\varnothing$  6 mm
- Greutate 19 kg
- Nu este recomandata pentru uz continuu
- Capacitate de 200 kg pe ora

cod	V	W	mm	lei
282200	230	750	370x220x(H)440	<b>3689,00</b>



Tava de incarcare  
din otel inoxidabil



Carcasa fabricata  
din otel inoxidabil



**PRODUCTIVITATE**  
pana la  
**200 kg/h**

Surub melc fabricat  
din aliaj de aluminiu

Recipient pentru  
carne din otel  
inoxidabil



### SITA - $\varnothing$ 70 mm

cod	potrivit pentru	mm	lei
282229	210802	$\varnothing$ 8	<b>89,99</b>
282250	210802	$\varnothing$ 3	<b>89,99</b>
282243	210802	$\varnothing$ 4.5	<b>89,99</b>
282236	210802	$\varnothing$ 6	<b>89,99</b>
282267	210802	$\varnothing$ 2	<b>89,99</b>



282267



282359

### CUTIT

cod	potrivit pentru	lei
282359	210802	<b>49,99</b>
282076	210819	<b>69,99</b>





**PRODUCTIVITATE**  
pana la  
**300 kg/h**

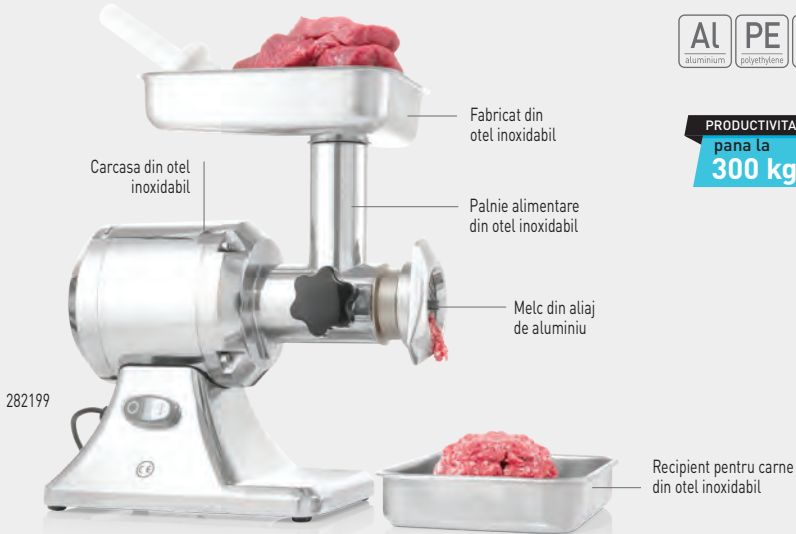

282199

### MASINA DE TOCAT CARNE PROFI LINE 12

- Carcasa, palnia si vasul pentru carne sunt confectionate din otel inoxidabil
- Melc fabricat din aliaj special de aluminiu
- Dispozitiv de impingere din polietilena
- Transmisie in ulei, silentioasa
- Diametrul sitei de 70 mm cu orificii de Ø 6 mm
- Greutate 19 kg
- Nu este recomandata pentru uz continuu
- Capacitate de 200 kg pe ora

cod	V	W	mm	lei
282199	230	750	370x220x(H)440	3299,00

### MASINA DE TOCAT CARNE PROFI LINE 22

- Carcasa, palnia si vasul pentru carne sunt confectionate din otel inoxidabil
- Melc fabricat din aliaj special de aluminiu
- Dispozitiv de impingere din polietilena
- Transmisie in ulei, silentioasa
- Diametrul sitei de 82 mm cu orificii de Ø 6 mm
- Greutate 24 kg
- Nu este recomandata pentru uz continuu
- Capacitate de 300 kg pe ora

cod	V	W	mm	lei
282007	230	1100	430x250x(H)510	4289,00



282267

#### SITA - ø 70 mm



cod	potrivit pentru	mm	lei
282229	210802	ø8	89,99
282250	210802	ø3	89,99
282243	210802	ø4.5	89,99
282236	210802	ø6	89,99
282267	210802	ø2	119,99



282359

#### CUTIT



cod	potrivit pentru	lei
282359	210802	49,99
282076	210819	69,99

#### SITA - ø 82 mm



cod	potrivit pentru	mm	lei
282014	210819	ø8	124,99
282021	210819	ø6	124,99
282038	210819	ø4.5	124,99
282045	210819	ø3	144,99
282052	210819	ø2	199,99

#### MELC

- Fabricat din aluminiu anodizat



cod	potrivit pentru	lei
282304	282199	299,99
282069	282007	449,99



Vezi filmul



Tava alimentare fabricata din otel inoxidabil

Palnie alimentare din aliaj de aluminiu special

Palnie carnati din polipropilena



Buton de resetare

210802

**PRODUCTIVITATE**  
pana la  
**220 kg/h**

### MASINA DE TOCAT CARNE KITCHEN LINE 12

- Tava alimentare din otel inoxidabil, carcasa din aliaj special de aluminiu
- Cutit si melc din otel inoxidabil, palnie din fonta
- Tub umplutura si doua discuri de tocare cu diametru 70 mm, cu orificii de 6 si 8 mm, incluse
- Dezasamblare usoara pentru curatare facila
- Motor cu mecanism protectie la supraincalzire
- Picioare non-alunecare
- Capacitate 100 kg/h
- Nu este recomandata pentru uz continuu

cod	V	W	mm	lei
210802	230	550	240x393x(H)560	2199,00

### MASINA DE TOCAT CARNE KITCHEN LINE 22

- Tava alimentare din otel inoxidabil, carcasa din aliaj special de aluminiu
- Cutit si melc din otel inoxidabil, palnie din fonta
- Tub umplutura si doua discuri de tocare cu diametru 82 mm, cu orificii de 6 si 8 mm, incluse
- Dezasamblare usoara pentru curatare facila
- Motor cu mecanism protectie la supraincalzire
- Picioare non-alunecare
- Capacitate 200-220 kg/h
- Nu este recomandata pentru uz continuu

cod	V	W	mm	lei
210819	230	750	239x424x(H)571	2399,00

### SITA - ø 70 mm



cod	potrivit pentru	mm	lei
282229	210802	ø8	89,99
282250	210802	ø3	89,99
282243	210802	ø4.5	89,99
282236	210802	ø6	89,99
282267	210802	ø2	119,99

### SITA - ø 82 mm



cod	potrivit pentru	mm	lei
282014	210819	ø8	124,99
282021	210819	ø6	124,99
282038	210819	ø4.5	124,99
282045	210819	ø3	144,99
282052	210819	ø2	191,99



### MELC



cod	potrivit pentru	lei
933367	210819	349,99
931257	210802	299,99



### CUTIT



cod	potrivit pentru	lei
282359	210802	49,99
282076	210819	69,99

S.S.  
stainless steelPRODUCTIVITATE  
pana la  
**150 kg/h**

Asamblare usoara  
si rapida a palniei  
in corpul motorului



Vezi filmul



282274

### MASINA DE TOCAT CARNE PROFI LINE 1/2 UNGER 12

- Proiectat pentru uz profesional, ideal pentru macelarii, supermarketuri, cantine mari, restaurante si alte unitati de catering.
- Pentru tocat orice tip de carne dezosata.
- Carcasa eleganta a motorului din aluminiu turnat si lustruit.
- Palnii din otel inoxidabil AISI 304.
- Echipament pentru lot de ulei (pentru o functionare lina si extra linistita)
- Palnie detasabila din otel inoxidabil.
- Motor asincron ventilat cu protectie impotriva supraincalzirii.
- Viteza de surub cu vierme: 140 RPM.
- Impingator de carne din polietilena
- Disc de tocat cu deschideri  $\phi 6,5$  mm si pre-taietori incluse.
- Tava cu bunca din otel inoxidabil.
- Deschidere de umplere:  $\phi 52$  mm.
- Diametrul de iesire a canalului:  $\phi 70$  mm.
- Rezultat: pana la 150 kg / h.
- Nu pentru utilizare continua.
- Greutate: 23 kg.

cod	V	W	mm	lei
282274	400	1100	460x240x(H)510	5319,00

 Al  
aluminium
 S.S.  
stainless steel
 indoor

Vezi filmul



Vas pentru carne  
cu capac pentru praf

Carcasa din  
aluminiu



210864

### MASINA DE TOCAT CARNE 198

- Ideala pentru cantitati mici si preparare carnati, nu pentru uz comercial
- Carcasa din aluminiu
- Palnie din fonta cu capac anti-praf si tava carne
- Impingator din plastic
- Melc din aluminiu, cutit din otel inoxidabil
- 2 discuri taiere cu diametru 65,8 mm, incluse: 4 mm si 7 mm diametrul orificiilor
- 3 tuburi umplere carnati:  $\phi 12$ , 15 si 20 mm
- Accesorii biftec tartar
- Intrerupator on/off/inapoi
- Nu pentru uz continuu
- Greutate 5,2 kg

cod	V	W	mm	lei
210864	230	400	195x274x(H)430	599,99



Sunt incluse trei tuburi de  
umplere pentru carnati

Melc din aluminiu, lama  
fabricata din otel inoxidabil



Vezi filmul



### FIERASTRAU ELECTRIC PENTRU OASE

- Pentru utilizare in gastronomia profesionala
- Corp realizat din aluminiu lacuit
- Elementele care intra in contact cu carnea sunt fabricate din otel inoxidabil
- Buton pentru oprire de urgenta
- Frana de motor
- Comutator capac (micrinteruptor)
- Reglarea grosimii si inaltimii de taiere
- Dimensiuni de taiere: 170x(H)150 mm
- Masa de fierastrau: 330 x 300 mm
- Greutate neta: 37 kg

cod	V	W	mm	lei
282502	230	750	530x400x(H)850	<b>8749,00</b>

282502



### FERASTRAU PENTRU OASE

- Lama interschimbabila din otel inoxidabil (AISI 420).
- Dimensiunile lamei: 450x20 mm (lungime totala: 475 mm).
- Duritate: 54-55HRC
- Cadru din otel carbon acoperit cu pulbere (AISI570).
- Maner profilat si sistem de blocare lama fabricat din polipropilena modificata Haiplen®.
- Greutate: 0,905 kg.

cod	mm	lei
1306.045	(L)580	<b>186,99</b>
1312.045	Lama din otel inoxidabil de 45 cm, pentru fierastrau 1306.045	<b>49,99</b>



1306.045

1312.045



Role pentru vita  
si porc incluse

Vezi filmul

**APARAT ELECTRIC FRAGEZIRE  
CARNE**

- Dimensiune maxima bucata de carne: 160 mm latime, 30 mm grosime
- Carcasa din otel inoxidabil
- Role pentru vita si porc, incluse
- Viteza cutit 75 rpm
- Motor racit cu ajutorul unui ventilator incorporat
- 4 picioare din cauciuc

cod	V	W	mm	lei
975305	230	350	514x224x(H)430	2779,00



975305



975329

**ROLE PENTRU CARNE DE PASARE**

- Carcasa din otel inoxidabil
- 2 role de presare din polipropilena
- Lungime rola 180 mm

cod	mm	lei
975329	235x130x(H)120	899,99



975312

**ROLE PENTRU SHAORMA**

- Carcasa si cutite din otel inoxidabil
- 2 seturi de cutite pentru taiere cu latimea de 4 mm
- Lungime rola 165 mm

cod	mm	lei
975312	235x130x(H)120	2199,00



843598

841464

**TOCATOR ELECTRIC**

- Carcasa fabricata din plastic ABS.
- 2 role cu 880 de lame pe rulmentii cu bile - fabricate din otel inoxidabil AISI 301, detasabile.
- Prevazut cu „piepteni”, care impiedica infasurarea carnii in jurul roletor.
- Picioare anti-alunecare.
- Functii: taiere, fragezire, batere a feliilor de carne.
- Deschidere intrare: 158x23 mm.
- Latime rola: 175 mm fiecare.
- Grosime max. bruta a carnii: 25 mm.
- Capacitate: pana la 420 de tocaturi/taieturi pe ora.
- Extensie cu fanta inclusa in set.

cod	V	W	mm	lei
843598	230	370	290x500x(H)490	4899,00



S.S. Al   
stainless steel aluminum



Vezi filmul

282113

### PRESA PENTRU HAMBURGER

- Pentru utilizare in gastronomie profesionala
- Carcasa inferioara din aluminiu anodizat
- Presa si tava din otel inoxidabil
- Presa face hamburgeri de pana la  $\phi$ 130 mm
- O parghie practica pentru a elibera carnea formata din tava
- Cu recipient despartitor de chifle integrat
- Despartitoarele pentru chifle sunt incluse in set

cod	mm	lei
282113	320x250x(H)300	824,99

### SEPARATOARE

- Fabricat din celuloza transparenta.
- Rezistent la temperaturi ridicate si biodegradabil.
- $\phi$ 130 mm.

cod	ambalat pe	mm	lei
282120	1255	$\phi$ 130	180,99



Al indoor   
aluminum indoor

513026

### PRESA HAMBURGER

- Fabricata din aliaj de aluminiu cu strat anti-aderent
- Maner din polipropilena
- Diametru hamburger  $\phi$ 115 mm

cod	mm	lei
513026	$\phi$ 120x(H)80	39,99



513033

Al wash   
aluminum wash

### PRESA PENTRU TORTILLA

- Diametru maxim tortilla 200 mm
- Fabricata din aliaj de aluminiu cu strat vopsea rosie la exterior

cod	mm	lei
513033	685x250x(H)200	89,99



Vezi filmul

## APARATE DE UMPLUT CARNATI

18/8

stainless steel



indoor

CAPACITATE

10 L



Vezi filmul

Sistem durabil de angrenare -  
realizat din oțel calitPartile care intra  
in contact cu  
alimentele sunt usor  
de demontat pentru  
umplere si curatare

282151

282151

Lipsa de oțel inoxidabil

## APARAT DE UMPLUT CARNATI PROFI LINE

- Corpul, cilindrul și pistonul - fabricate din oțel inoxidabil
- Echipat cu un sistem de umplere cu 2 viteze ușor de folosit
- Pistonul poate fi scos ușor pentru curățare și umplere
- Echipat cu rulmenți și mecanism din oțel întărit, rezistent la presiune
- Cu un set de 4 palnii din oțel inoxidabil cu diametre 16/22/32/38 mm

cod	litri	mm	lei
282571	3	304x304x(H)525	709,99
282588	5	304x304x(H)640	799,99
282090	7	300x340x(H)830	899,99
282151	10	415x315x(H)690	1199,00

Cu un set de 4 palnii  
din oțel inoxidabil  
diametru: 16/22/32/38 mm

**S.S.**  
stainless steel



282083

## DISPOZITIV ELECTRIC DE UMPLUT CARNATI, 15 L

- Fabricat din otel inoxidabil
- Capacitate: 15 l = aprox. 13 kg de carne
- Motor electric care deplaseaza pistonul de umplere
- Viteza reglabila a deplasarii pistonului (0-10 mm / s) permite reglarea precisa a vitezei de umplere in functie de consistenta umpluturii, precum si de dimensiunea si grosimea carcasei
- Poate fi pornit cu pedala
- Inclus 4 conuri cu urmatoarele diametre: 16/22/32/38 mm, toate 180 mm lungime
- Sistem de angrenaje rezistent la sollicitari mecanice datorita materialelor din otel ranforsat
- Greutate: 30 kg

cod	litri	V	W	mm	lei
282083	15	230	60	450x350x(H)750	2469,00



## CLIPPER MANUAL PENTRU CARNATI

- Fabricat din otel cromat.
- Mecanism de prindere protejat cu strat ABS.
- Inchideti diferite tipuri de ambalaje rapid, fara scurgeri si fara efort cu ajutorul unei cleme stranse datorita manetei lungi de 390 mm.
- Cu sine lungi, prevazute cu greutate pentru a asigura pozitia corecta a clemelor.
- Reglarea clemei de prindere prin intermediul unui buton cu surub de blocare (este posibila selectarea clemei potrivite in functie de tipul si grosimea carcasei, plasei, sacului etc.)
- Baza grea pentru stabilitate suplimentara in timpul functionarii.
- Echipat cu picioare de cauciuc pentru a proteja suprafetele de lucru.
- Greutate neta: 15 kg
- Vine cu 1000 de cleme in forma de U, dimensiuni: 11,5x11 mm.
- Cleme disponibile separat in pachete de 2000 buc. (265123).

cod	mm	lei
265116	150x350x(H)500	724,99
265123	Clipsuri pentru carnati - 2000 buc.	79,99



265123



265116



282670

### MASINA DE TOCAT CARNE MANUALA

- Dispozitiv pentru amestecarea carni tocate cu alte adaosuri, cum ar fi condimentele, pentru a obtine umplutura pentru carnati si alte produse de carne.
- Operare manuala folosind o manivela.
- Accesoriu la modelul 282687.
- Carcasa din otel inoxidabil AISI 304.
- Foarte usor de utilizat si de curatat.

cod	litri	mm	lei
282670	10	450x230x(H)335	<b>731,99</b>
282687	18	580x250x(H)415	<b>861,99</b>



282281

### MALAXOR MANUAL PENTRU CARNE CU SISTEM DE DESCARCARE

- Dispozitiv pentru producția de produse din carne în cantități mici
- Protecție dubla față de dislocarea accidentală a ansamblului de otel inoxidabil AISI 304
- Maner turnat din aluminiu
- Canalizator de tăiere pentru scoaterea mai ușoară a umpluturii
- Funcționarea automată cu maner demontabil
- Fără sistem de angrenare în modelul 282168, numărul de rotații ale manivelei este egal cu numărul de rotații ale agitatorului
- Angrenajul din modelul 282281, 3 rotații ale manivelei egale cu o rotație a agitatorului
- Canalul și agitatorul pot fi demontate
- Usor de folosit si curatat

cod	litri	mm	lei
282168	11	240x460x(H)410	<b>759,99</b>
282281	20	285x550x(H)385	<b>938,99</b>



265109

### TAIETOR ELECTRIC CARNATI

- Taietor electric carnati cu lama dubla si grosime de taiere reglabila
- Canal extra lung de inserare pentru toate tipurile de carnati
- Diametru maxim 48 mm

cod	V	W	mm	lei
265109	230	135	255x187x(H)330	<b>958,99</b>



222805

### TAIETOR CARNATI - MANUAL

- Baza stabila cu ventuze
- Lame zimtate de inalta calitate
- Usor de curatat
- Taie 11 bucati - 17 mm

cod	mm	lei
222805	275x170x(H)235	<b>610,99</b>

## MASINI CURATAT CARTOFI KITCHEN LINE



- Destinat utilizarii profesionale, echipament esential pentru orice bucatarie in care cartofii si alte radacinoase trebuie curatate in fiecare zi
- Curatare cu un disc abraziv si tampoane abrazive pe interiorul tamburului
- Structura, disc si saibe din otel inoxidabil de inalta calitate, facand masina foarte durabila, eficienta si usor de curatat
- Discul abraziv este echipat cu agitatoare din aliaj de aluminiu
- Capac din policarbonat rezistent; va permite sa observati procesul de curatare
- Motor puternic permite curatarea intr-un ciclu de 2-3 minute
- Panou de control cu temporizator de 8 minute si lumini indicatoare

- Foarte sigur de utilizat, microintreruptorul opreste dispozitivul atunci cand capacul este deschis
- Prevazut cu racord pentru apa proaspata si scurgere, pentru clatirea cartofilor in timp ce se curata de coaja
- Separatorul pentru colectarea pielilor (rezervor cu insertie perforata) reduce eficient riscul de infundare a sistemului de canalizare cu apa scursa din decojite
- 4 picioare cu picioare din plastic incluse
- 2 echipat cu placi de montaj - pentru montarea stabila a dispozitivului la sol
- Clasa de impermeabilitate: IP23



229224



229217



229200

### MASINA CURATAT CARTOFI KITCHEN LINE 18 KG

- Capacitatea de 18 kg de cartofi pe sarcina, poate curata 240 pana la 360 kg pe ora.
- Greutate: 42,4 kg.

cod	V	W	mm	lei
229224	230	1100	622x540	5899,00
			x(H)997	

### MASINA CURATAT CARTOFI KITCHEN LINE, 10 KG

- Capacitatea de 10 kg de cartofi pe sarcina, poate curata 140 pana la 200 kg pe ora.
- Greutate: 39,6 kg.

cod	V	W	mm	lei
229217	230	750	620x525	5299,00
			x(H)833	

### MASINA CURATAT CARTOFI KITCHEN LINE, 5 KG

- Capacitatea de 5 kg de cartofi pe incarcatura, poate curata 70 pana la 100 kg pe ora.
- Greutate: 37,5 kg.

cod	V	W	mm	lei
229200	230	550	620x525	4999,00
			x(H)787	



S.S.  
stainless steelTemporizator  
digitalTemporizator  
digital

226810



Capac transparent

Capcanule  
de cauciuc

226834

**MASINA CURATAT CARTOFI PROFI LINE 10**

- Constructie din otel inoxidabil
- Capac transparent
- Timer digital
- Orificiu evacuare sub aparat
- Disc abraziv
- Peretii interiori captusiti cu material abraziv detasabil
- Buton oprire de urgenta
- Conform normelor CE
- Posibilitate inlocuire placi abrazive
- Productivitate 100 kg/h
- Greutate 40 kg

cod	capacitate	V	W	mm	lei
226810	10 kg	400	550	530x660x(H)850	<b>9859,00</b>

**MASINA CURATAT CARTOFI PROFI LINE 5**

- Constructie din otel inoxidabil
- Capac transparent
- Timer digital
- Orificiu evacuare sub aparat
- Disc abraziv
- Peretii interiori captusiti cu material abraziv detasabil
- Buton oprire de urgenta
- Productivitate 75 kg/h
- Greutate 35 kg

cod	capacitate	V	W	mm	lei
226834	5 kg	230	370	530x520x(H)700	<b>8769,00</b>



1000660



1000630



## MASINA DE CURATAT CARTOFI SERIA PI

- Dispozitiv profesional pentru curatarea cartofilor, sfeclii rosii, morcovilor si alte legume tari
- Partea inferioara a cuvei sub forma unei placi rotative, din aluminiu, acoperita cu material abraziv cu carbura de silicon (certificare NSF)
- 2 sau 3 elemente abrazive in functie de model
- Structura din otel inoxidabil, usa laterala din aluminiu
- Capac transparent din policarbonat
- Consum redus de energie datorita optimizarii motorului
- Intrerupator de siguranta pentru capac si usa
- Coeficient de scurgere: IP65
- Rezistenta ridicata la umiditate si stropire cu apa
- Panou de control impermeabil cu butoane: START, STOP
- Cronometru cu 0-6 minute reglabil si mod de functionare continua

- Este necesara conexiunea la apa
- Dotat cu o supapa care impiedica returul apei catre retaua de alimentare cu apa
- Sifon lateral sau vertical inferior cu diametrul de 80 mm din care sa alegeți in timpul asamblării
- Nivel de zgomot: aprox. 70 dB

cod	1000650	1000660	1000630
model	PI-10	PI-20	PI-30
dimensiuni	433x635 x(H)625 mm	433x635 x(H)735 mm	622x760 x(H)950 mm
productivitate	200-240 kg/h	400-480 kg/h	600-720 kg/h
capacitate	10 kg	20 kg	30 kg
putere	370 W/400 V	550 W/400 V	730 W/400 V
greutate	34 kg	35,8 kg	56,9 kg
lei	<b>9389,00</b>	<b>11699,00</b>	<b>17299,00</b>

## ACCESORII

cod		lei
2001417	Placa abraziva inferioara pentru PI-10 si PI-20	<b>1099,00</b>
2003899	Placa abraziva inferioara pentru decojitor M-5	<b>1149,00</b>
2009430	Placa abraziva inferioara pentru PI-30	<b>1299,00</b>
2009422	Element abraziv lateral pentru PI-10	<b>259,99</b>
2009423	Element abraziv lateral pentru PI-20	<b>419,99</b>
2009415	Element abraziv lateral pentru PI-30	<b>529,99</b>
2009224	Suport pentru M-5 si PI-10, PI-20	<b>1409,00</b>
2009250	Suport cu sertar pentru PI-10 si PI-20	<b>3199,00</b>
2009270	Suport cu sertar pentru PI-30	<b>3799,00</b>
2000004	Disc cu cutite de curatat PI-20	<b>2099,00</b>

**FELIATOARE PROFI LINE**

- Carcasa din aluminiu acoperit.
- Lama inclinata din otel inoxidabil calit.
- Motor cu racire cu aer, cu protectie impotriva supraincalzirii.
- Motor de mare putere pentru felierea carnii tari.
- Echipat cu aparatoare pentru lama si sistem de ascutire incorporat.
- Sanie cu scut de protectie si opritor pentru cantitatea ramasa cu sistem de blocare vertical.
- Rapid si usor de demontat pentru curatare.



- Indepineste toate cerintele de siguranta pentru utilizarea comerciala, precum:
  - Reglarea la grosimea 0 mentine lama in spatele aparatorii.
  - Protectie la activare daca sistemul de ascutire sau capacul axului nu sunt montate.
  - Sania poate fi blocata si scoasa doar daca lama este reglata la grosimea 0.
- Nu este potrivit pentru taierea branzii. Pentru taierea branzii, sunt necesare cutite acoperite cu teflon (975800, 975732, 975749, 975756).



210031

**FELIATOR PROFI LINE 195**

- Diametru lama 195 mm
- Grosimea de taiere reglabila, pana la 12 mm
- Diametru maxim feliere: 120 mm

cod	V	W	mm	lei
210031	230	200	416x400x(H)335	<b>1399,00</b>



210048

**FELIATOR PROFI LINE 220**

- Diametru lama 220 mm
- Grosimea de taiere reglabila, pana la 15 mm
- Diametru maxim feliere: 150 mm

cod	V	W	mm	lei
210048	230	280	506x435x(H)347	<b>1519,00</b>



Protectie acrilica de siguranta



Carucior cu mecanism de blocare



Ascutitor incorporat



Protectie lama



Comutator de pornire/oprire de siguranta etans



Motor racit cu aer protejat de capac metalic



Vezi filmul

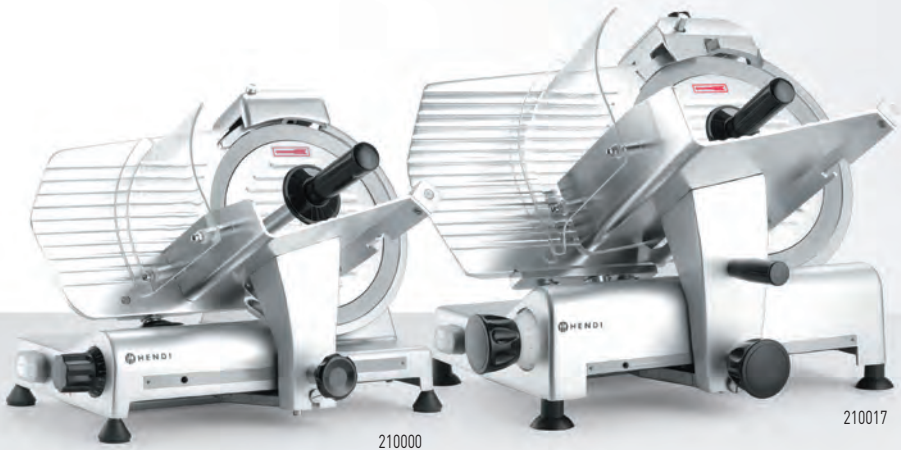

210000

210017

### FELIATOR PROFI LINE 250

- Diametru lama 250 mm
- Grosimea de taiere reglabila, pana la 15 mm
- Diametru maxim feliere: 180 mm

cod	V	W	mm	lei
210000	230	320	514x484x(H)373	1759,00

### FELIATOR PROFI LINE 300

- Diametru lama 300 mm
- Grosimea de taiere reglabila, pana la 15 mm
- Diametru maxim feliere: 200 mm

cod	V	W	mm	lei
210017	230	420	602x573x(H)456	2899,00

### CUTIT CU STRAT ANTI-ADERENT

- Pentru feliere branza

cod	potrivit pentru	mm	lei
975800	210031	ø195	349,99
975732	210048	ø220	404,99
975749	210000	ø250	459,99
975756	210017	ø300	599,99



Vezi filmul



975732





## FELIATOARE PROFI LINE

- Carcasa din aluminiu acoperit.
- Lama inclinata din otel inoxidabil calit.
- Motor cu racire cu aer, cu protectie impotriva supraincalzirii.
- Motor de mare putere pentru felierea carnilor tari.
- Echipat cu aparatoare pentru lama si sistem de ascutire incorporat.
- Sanie de munca cu scut de protectie si opritor pentru cantitatea ramasa cu sistem de blocare vertical.
- Rapid si usor de demontat pentru curatare.



- Indepineste toate cerintele de siguranta pentru utilizarea comerciala, precum:
  - Reglarea la grosimea 0 mentine lama in spatele aparatorii.
  - Protectie la activare daca sistemul de ascutire sau capacul axului nu sunt montate.
  - Sania poate fi blocata si scoasa doar daca lama este reglata la grosimea 0.
- Nu este potrivit pentru taierea branzii. Pentru taierea branzii, sunt necesare cutite acoperite cu teflon (975800, 975732, 975749, 975756).



Vezi filmul



970294



210086

### FELIATOR PROFI LINE 220 - ROSU

- Diametru lama: 220 mm
- Grosimea de taiere reglabila, pana la 15 mm
- Diametru maxim feliere: 150 mm
- Finisat cu un strat rosu

cod	V	W	mm	lei
970294	230	280	506x435x(H)347	1529,00

### FELIATOR PROFI LINE 250 - ROSU

- Diametru lama 250 mm
- Grosimea de taiere reglabila, pana la 15 mm
- Diametru maxim feliere: 180 mm

cod	V	W	mm	lei
210086	220-240	320	514x484x(H)373	1779,00



Grosimea felierii este usor de reglat



Carucior cu mecanism de blocare



Ascutitor incorporat



Suport pentru produse grele



Protectie acrilica de siguranta

## FELIATOARE KITCHEN LINE

- Carcasa din aluminiu anodizat.
- Capac de siguranta transparent in timpul lucrului.
- Ghid desurubat pentru curatarea usoara a resturilor ramase dupa taiere.
- Protectia cutitului poate fi indepartata cu usurinta pentru curatare.



- Protectie sigura a cutitelor, ascutitor incorporat.
- Cutit oblic de inalta calitate.
- Protectie impotriva rotatiei cutitului la scoaterea carcasei.
- 4 picioare din plastic antiderapante.

### FELIATOR KITCHEN LINE 250

- Carcasa aluminiu anodizat
- Motor 0.2 hp, racit cu aer, protejat de capacul din plastic
- Protectie lama si sistem ascutire inclus
- Diametru lama: 250 mm
- Diametru maxim pentru produsele ce pot fi feliate: 180 mm
- Grosime feliere reglabila, pana la 8 mm
- Lama cu sistem protectie, nu functioneaza cand carcasa este indepartata 4 picioare anti-alunecare din plastic
- Greutate: 16.4 kg

cod	V	W	mm	lei
210215	230	150	494x402x(H)398	1879,00



210215



Vezi filmul

### FELIATOR KITCHEN LINE 300

- Carcasa aluminiu anodizat
- Motor 0,3 hp, racit cu aer, protejat de capacul din plastic
- Lama de inalta calitate, model inclinat
- Diametru lama: 300 mm
- Diametru maxim pentru produsele ce pot fi feliate: 210 mm
- Grosime feliere reglabila, pana la 13 mm
- Greutate: 24,5 kg

cod	V	W	mm	lei
210246	230	250	615x494x(H)477	2809,00



210246

### FELIATOR KITCHEN LINE 250 - TEFLON

- Carcasa aluminiu anodizat
- Lama, protectia lamei si tava pentru produs sunt acoperite cu Teflon, pentru taiere usoara a branzeturilor
- Motor 0.2 hp, racit cu aer, protejat de capacul din plastic
- Protectie lama si sistem de ascutire incluse
- Lama de inalta calitate, model inclinat
- Diametru lama: 250 mm
- Diametru maxim pentru produsele ce pot fi feliate: 180 mm
- Grosime feliere reglabila, pana la 8 mm
- Greutate: 16.4 kg

cod	V	W	mm	lei
210222	230	150	494x402x(H)398	1999,00



210222

Teflon acoperit  
cu branza feliată



Vezi filmul

Protectie acrilica  
de siguranta



Ascutitor  
incorporat



Motor  
ventilat



Buton ON/OFF  
protejat





## FELIATOARE ELECTRICE HEAVY DUTY



- Fabricat manual in Italia
- Carcasa din aluminiu, sanie fabricatga din otel inoxidabil
- Lama din otel inoxidabil
- Grosimea feliilor este ajustabila cu un buton, de la 0 mm la 16 mm
- Ascutitor incorporat
- Motor cu racire prin aer
- Puterea mare a motorului si lama universala va permit felierea carnatilor, branzeturilor, produselor congelate, dar si a produselor din carne fara os sau a pestelui.

- Indeplineste toate criteriile de securitate printr care si:
  - Setarea butonului la grosimea de 0 mm, mentine lama in spatele garzii de protectie
  - Feliatorul nu porneste daca ascutitorul nu este instalat corect
  - Posibilitatea de a dezasambla sania daca grosimea este setata la 0 mm
  - Protectie impotriva taierii datorita garzii incorporate
  - Optiunea de a dezasambla garda fabricata din otel inoxidabil, pentru curatare in masina de spalat - mentinere usoara a igienei

NOU

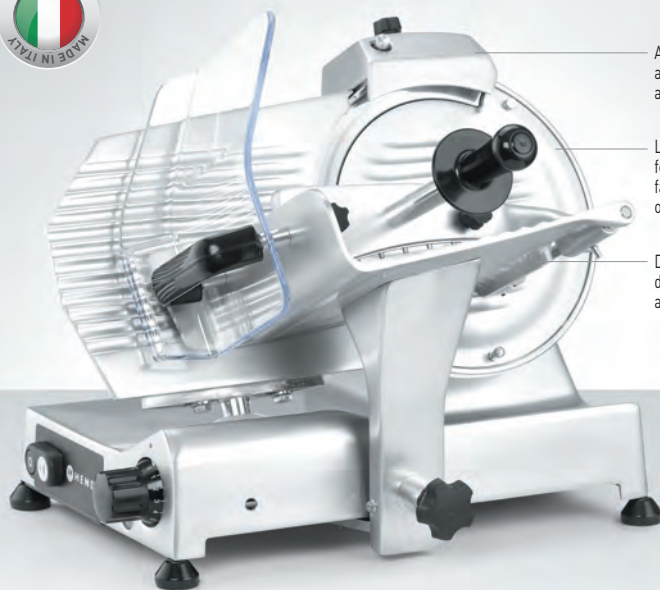

Ascutitoare incorporata, care asigura o eficienta constanta a discului de taiere

Lama universala pentru felierea carnii si branzeturilor, fara a fi nevoie sa cumarati o lama de teflon

Dezinfectare usoara - dezasamblarea simpla a tuturor pieselor



Protectie acrilica de siguranta



Protectia lamei sub forma de un inel montat permanent



Reglarea grosimii feliilor prin intermediul butonului, de la 0 mm la 16 mm



210918

### FELIATOR 250

- Dimensiunea aproximativa a produsului feliat: 220x190 mm

cod	V	W	mm	lei
210918	230	220	620x425x(H)370	4089,00



210925

### FELIATOR 300

- Dimensiunea aproximativa a produsului feliat: 220x190 mm

cod	V	W	mm	lei
210925	230	250	650x485x(H)440	5529,00



210932

### FELIATOR 350

- Dimensiunea aproximativa a produsului feliat: 310x260 mm.

cod	V	W	mm	lei
210932	230	370	890x585x(H)480	9589,00

### FELIATOR AUTOMAT



210949

### FELIATOR AUTOMAT 350

- Dimensiunea aproximativa a produsului feliat: 310x260 mm

- Sania se poate misca automat
- Posibilitatea de a programa diferite viteze de feliere
- Feliatorul numara feliile

cod	V	W	mm	lei
210949	230	370	990x670x(H)730	16749,00





210956



210963

**NOU**

Vezi filmul

**FELIATOR MANUAL RETRO 300**

- Fabricat manual in Italia
- Design unic retro de lux
- Operare manuala cu ajutorul unui maner
- Carcasa din aluminiu
- Lama din otel inoxidabil
- Ascutitor lama integrat
- Ajustare grosime feliere: de la 0 mm la 2.5 mm (9 trepte)
- Dimensiunea aproximativa a produsului feliat: 230x180 mm

cod	mm	lei
210956	720x600x(H)740	19899,00

**BAZA PENTRU FELIATOR MANUAL RETRO 300**

- Conceput pentru a fi utilizat impreuna cu feliatorul manual HENDI Retro 300 (cod: 210956)
- Conceput din aluminiu si otel inoxidabil
- Dimensiunea platformei: 400x500 mm

cod	mm	lei
210963	500x650x(H)800	5759,00



18/0  
stainless steel

18/10  
stainless steel



**NOU**

### SUPORT PENTRU JAMBON

- Suport si baza fabricate din otel inoxidabil cu finisaj satinat.
- Jambonul este fixat cu un surub in inel (ø80 mm). Inelul permite rotirea jambonului, oferind acces usor la fiecare bucata de carne.
- Elementul de sustinere cu un sistem de inclinare.
- Distaanta dintre suruburile de montare: aprox. 480 mm.
- Dimensiunile bazei: 570x215x(H)35 mm.
- Destinat montarii manuale (cheie hexagonala inclusa in set).

cod	mm	lei
499948	595x215x(H)300	1499,00



499948

# BLACKBOLT

O SUPER PUTERE IN BUCATARIA TA



Vezi filmul

PUTERE  
1500 W



## FUNCTII PRINCIPALE



framantare aluat



prajituri



bezea



batere albusuri

## MIXER PLANETAR HENDI BLACKBOLT

- Pentru framantarea aluatului si beza.
- Carcasa din aluminiu.
- Echipat cu un vas din otel inoxidabil usor, pentru framantarea cantitatilor mici de aluat.
- Amestecare uniforma.
- Aparatul este stabil pe durata functionarii.
- Motor silentios cu durata de functionare indelungata garantata.
- Sistemul de racire permite aparatului sa functioneze continuu timp de 60 de minute. 11 posibile setari de viteza.
- Capacitate: 7 l.
- 0,2-1,5 kg de faina.
- 2-20 albusuri de ou.

- 150-1.500 ml de smantana dulce.
- 0,1-2 l de crema proaspata.
- Cronometru.
- Maner acoperit cu silicon in conformitate cu standardele CE.
- 4 programe: Aluat, prajitura cu burete, frisca, biciuire cu ou.
- Accesorii (incluse):
  - tel de oua din otel inoxidabil AISI 304.
  - mixer din otel inoxidabil AISI 304 si carlig pentru aluat.
  - capac transparent pentru vas.
- Accesoriiile pot fi spalate in masina de spalat vase.

cod	V	W	mm	lei
221570	230	1500	460x310x(H)379	2399,00



**CUREA IN FORMA DE V**  
Garanteaza durabilitate ridicata

**CARCASA**  
Robusta, fabricata din aluminiu turnat

**SOFT START**  
Viteza variabila, reglabila prin intermediul unui variator de viteza cu 11 trepte

**BOL - 7 LITRI**  
Fabricat din otel rezistent la acizi - AISI 304  
Echipat cu un maner ergonomic acoperit cu un strat antialunecare



**COMPONENTE**  
Extrem de solide - realizate din otel inoxidabil, pentru o rotatie echilibrata. Tranzitie usoara intre treptele de putere

**PANOU DE CONTROL**  
Usor de citit si de proiectat  
Cronometru  
4 programe automate:  
- Amestecare lenta (viteza 1-6)  
- Mixer standard (viteza 1-8)  
- Amestecare delicata (viteza 1-9)  
- Amestecare rapida (viteza 1-11)

**CAPAC CU DISPENSER**  
Adaugarea facila a ingredientelor in timpul functionarii dispozitivului, fara a va face griji cu privire la murdarirea blatului



**CARLIG PENTRU ALUAT GREU**  
otel inoxidabil AISI 304



**TEL PENTRU BEZEA**  
otel inoxidabil AISI 304



**PALETA 1**  
silicon - POM



**PALETA 2**  
otel inoxidabil AISI 304



**BOL 7 L**  
otel inoxidabil AISI 304



ECHIPAMENTE  
PROCESARE



**HENDI** - BE INSPIRED!

Tools for Chefs



240



## BOL SUPLIMENTAR PENTRU MIXERUL BLACKBOLT

- Fabricat din otel inoxidabil AISI 304.
- Otelul este lustruit la exterior, satinat la interior.
- Prevazut cu un maner vertical robust si ergonomic, securizat cu material sintetic flexibil, pentru o priza sigura si protectie impotriva alunecarii.
- Capacitate: 7 l
  - 0,2-1,5 kg faina
  - 2-20 albusuri de ou
  - 150-1500 ml crema dulce
  - 0,1-2 l de smantana proaspata
- Se potriveste la mixerul planetar HENDI Black Bolt (cod: 221570).
- Poate fi spalat in masina de spalat vase.

cod	litri	mm	lei
963234	7	ø237x(H)208	149,99

**NOU**



963234



230114

**NOU**



## ACCESORIU TOCARE CARNE PENTRU MIXERUL HENDI BLACKBOLT

- Set complet pentru tocarea carnilor
- Tava de incarcare si palnie din otel inoxidabil
- Dispozitiv de impingere din PP si POM
- Site cu orificii: ø3, ø5, ø7 mm
- Orificiu de incarcare: 43 mm
- Compatibil numai cu mixerul planetar HENDI BLACKBOLT (cod:221570)

cod	mm	lei
230114	137x92x(H)266	314,99



230121

**NOU**



## SET 3 ACCESORII PENTRU PASTE PENTRU MIXERUL PLANETAR HENDI BLACKBOLT

- Carcasa, role si taietoare din otel inoxidabil
- Setul include 3 accesorii diferite pentru paste
- Rola pentru paste - poate fi utilizata pentru foile de lasagna, avand o latime de 140 mm si 8 trepte de ajustare
- Accesoriu pentru spaghetti cu o grosime de 1.6 mm
- Accesoriu pentru tagliatelle cu o grosime de 6.3 mm
- Accesoriile sunt compatibile numai cu mixerul planetar HENDI BLACKBOLT

cod	mm	lei
230121	220x51x(H)88	817,99

**MIXERE PLANETARE**

- Structura din aliaj de aluminiu si fonta vopsita in alb (226292)
- Aparatoare pentru bol turnata prin injectie din plastic si otel inoxidabil (pe modelul 226292)
- Bol solid din otel inoxidabil AISI304
- Setul include 3 ACCESORII din aluminiu: un tel, un agitator si un carlig pentru aluat
- Control digital sau manual (226292)
- Transmisie si angrenaje durabile din aliaj de otel SNCM21, alte componente din cupru
- Arbori incorporati in rulmenti cu bile
- Maneta pentru coborarea si ridicarea vasului
- Temporizator: pana la 30 de minute (pentru modelul 226292 pana la 15 minute)
- Protectie impotriva pornirii mixerului cu protectia ridicata sau cu bolul in pozitie gresita

430  
stainless steelS.S.  
stainless steel

226261



226292



cod	226261	226292
litri	6,6 l	18,9 l
dimensiuni	1 kg/1,6 kg	2,3 kg/3,68 kg
control	336x460x(H)518 mm	460x520x(H)880 mm
viteza	ø260x(H)195 mm	ø348x(H)290 mm
timer	digital	manual
motor	5 - 193-495 rpm	3 - 142, 264, 482 rpm
putere	pana la 30 min	pana la 15 min
greutate	3/4 KM = 552 W	1/2 KM = 368 W
putere	650 W/230 V	375 W/230 V
greutate	18 kg	100 kg
lei	5099,00	10499,00

## MIXERE PLANETARE

- Carcasa din aluminiu (model: 222829) sau carcasa din fonta pentru patru suporturi (model: 222836, 222843)
- Bol solid din otel inoxidabil AISI201
- Setul include 3 ACCESORII din otel inoxidabil AISI430: tel, agitator si cartlig pentru aluat
- 3 viteze
- Angrenaj durabil din otel cromat
- Maneta pentru coborarea si ridicarea vasului
- Panou de control digital usor de utilizat (model: 222829) sau comenzi mecanice (model: 222836, 222843)
- Protectie impotriva pornirii mixerului atunci cand capacul sau bolul sunt in pozitie gresita
- Protectie la supraincalzire care poate fi resetata
- Timerul poate fi setat pana la 60 de minute (model: 222829)



Vezi filmul



CAPACITATE MAX.

**5 kg**



222829



222836



222843



cod	222829	222836	222843
litri	7 l	10 l	20 l
capacitate maxima de mixare faina	0,8 kg/2 kg	2,5 kg/4 kg	5 kg/8 kg
dimensiuni	240x420x(H)425 mm	380x470x(H)730 mm	490x580x(H)780 mm
control	digital	manual	manual
viteza	128/252/545 rpm	148/244/480 rpm	197/317/462 rpm
putere	650 W/230 V	600 W/230 V	1100 W/230 V
lei	<b>2669,00</b>	<b>3299,00</b>	<b>3919,00</b>





## MIXER TURBO TRX-22



- Mixerul turbo este conceput pentru amestecarea și procesarea alimentelor în vase cu o capacitate de până la 800 de litri, adică în bucatariile de mare capacitate și chiar în industria alimentară
- Ideal pentru amestecarea alimentelor direct în vasul de gătit
- Bratul lung de 600 mm este potrivit pentru orice tip de vas, rotund sau dreptunghiular. Fabricat în întregime din oțel inoxidabil 18/10
- Usor de utilizat: se poate deplasa în diferite direcții, reglabil pe înălțime, montare pe carucior cu 4 roți din cauciuc antiderapant, dintre care 2 cu frână
- Echilibrul perfect al bratului de maruntire împiedică rasturnarea sau înclinarea dispozitivului în spate, chiar dacă bratul sau roțile suportului nu sunt blocate
- Parghia de blocare va permite să blocați bratul cu o singură mână
- Panou de rezistență la apă, ușor accesibil
- 2 viteze: 750 și 1500 rpm
- Panou de control cu temporizator încorporat: posibilitatea de a lăsa dispozitivul să funcționeze până la 60 de minute fără a fi nevoie de supraveghere
- Cabluri electrice ascunse în cadrul caruciorului, suprafața de lucru este liberă de orice obstacole care restricționează miscarea liberă a bratului de amestecare
- Componentele sunt ușor de îndepărtat, fără unelte necesare; se pot spăla în mașina de spălat vase
- Microîntrerupător de siguranță care controlează poziția dispozitivului: nu permite turbinei să funcționeze când bratul este prea sus sau prea jos
- 3 accesorii de amestec opționale și ușor de înlocuit



Vezi filmul

cod	3030506
model	TRX-22
dimensiuni în timpul funcționării	568x1643x(H)1219 mm
dimensiuni pliată	568x963x(H)1651 mm
viteză	750 - 1500 rpm
Lungimea bratului	600 mm
putere	2200 W/400 V
greutate	96 kg
lei	<b>34599,00</b>



3 amestecări opționale și ușor de înlocuit (dispozitivele de întindere nu se rotesc)



4032401

4032403

4032389

### ACCESORII

cod		lei
4032401	21D sita pentru TRX-22 pentru amestecarea ingredientelor fibroase	<b>1179,00</b>
4032403	30D sita pentru TRX-22 universală	<b>1179,00</b>
4032389	42D sita pentru TRX-22 pentru amestecare precisă	<b>1179,00</b>

## BLENDERE STICK PROFI LINE

- Versiune profesionala
- Carcasa din nylon armat cu fibra
- Lama si tija din otel inoxidabil
- Usor de curatat



Echipat cu un afisaj digital



cod	224328	224335	224397	224359	224052
	Blender stick 250 - cu viteza fixa	Blender stick Profi Line 300 - cu viteza reglabila	Blender stick Profi Line 400 - cu viteza reglabila	Blender stick Profi Line 500 - cu viteza reglabila	Blender stick Profi Line 500, motor puternic, cu viteza ajustabila
control		Panou electronic de control cu 9 trepte de viteza	Panou electronic de control cu 9 trepte de viteza	Panou electronic de control cu 9 trepte de viteza	Panou electronic de control cu 9 trepte de viteza
capacitate pana (lit)	20	50	80	100	120
dimensiuni (mm)	ø75x(H)285	ø100x(H)350	ø100x(H)350	ø100x(H)350	ø100x(H)350
lungimea tijei (mm)	250	300	400	500	500
viteza (rpm)	fixa 15 000	variabila 2 000 - 9 000	variabila 2 000 - 9 000	variabila 2 000 - 9 000	variabila 2 000 - 9 000
viteza maxima (rpm)		13 000	15 000	15 000	15 000
putere (W/V)	250/230	300/230	400/230	400/230	500/230
greutate (kg)	1,45	3,45	4,1	4,1	4,25
lei	1089,00	1679,00	1989,00	2099,00	2399,00



### TEL PENTRU BLENDER STICK PROFI LINE 300, 400 & 500

- Contine 2 teluri. Usor si sigur de atasat.
- Adecvat pentru: 224335, 224397, 224359, 224052, 224380, 282311

cod	mm	lei
224342	ø120x(H)330	745,99



934029

### SISTEM PRINDERE PERETE

cod	mm	lei
934029	365x130x(H)70	159,99





## UNITATE MOTOR PENTRU BLENDERELE STICK KITCHEN LINE

- Carcasa realizata din polyamida neagra intarita cu fibra de sticla
- Lama demontabila din otel AISI304
- Inclus in set: mini kit pentru dezasamblarea lamelor
- Viteze variabile cu reglaj usor din buton: de la 4000 la 16000 RPM
- Motor ventilat:
- Buton de siguranta ce impiedica pornirea accidentala a mixerului
- Buton de blocare ce permite functionarea continua fara apasarea continua a butonului de pornire



Buton ergonomic pentru  
reglarea vitezelor

Buton suplimentar  
de siguranta

Grilaj motor care  
permite ventilarea  
eficienta

Atasare in siguranta  
a bratului de amestecare

Lama conceputa special  
pentru a preveni stropirea

## AX BLENDER PENTRU BLENDER STICK

- Lama si ax din otel inoxidabil
- Pentru 221884, 221891, 221198, 221327, 221334, 221341.
- Set de demontare a lamei inclus

cod	mm	lei
222225	(L)250	<b>319,99</b>
222232	(L)300	<b>379,99</b>
222249	(L)400	<b>389,99</b>
222256	(L)500	<b>469,99</b>

**NOU**



## TEL PENTRU BLENDER STICK 221884 & 221891

- Contine 2 teluri din otel inoxidabil
- Atasare usoara si sigura la unitate motor
- Pentru 221884, 221891, 221198, 221327, 221334, 221341.

cod	mm	lei
222263	(L)250	<b>409,99</b>



**NOU**



cod	221198	221327	221334	221341
	Blender vertical 350 cu viteza variabila si brat de amestecare 250 mm	Blender vertical 350 cu viteza variabila si brat de amestecare 300 mm	Blender vertical 500 cu viteza variabila si ax de amestecare 400 mm	Blender vertical 500 cu viteza variabila si ax de amestecare 500 mm
capacitate pana (lt)	20	30	80	100
dimensiuni (mm)	ø100x(H)666	ø100x(H)716	ø100x816	ø100x916
lungimea tijei (mm)	250	300	400	500
viteza (rpm)	de la 4 000 la 16 000	de la 4 000 la 16 000	de la 4 000 la 16 000	de la 4 000 la 16 000
putere (W/V)	350/230	350/230	500/230	400/230
lei	1049,00	1099,00	1199,00	1319,00

### BLENDER STICK KITCHEN LINE 160 – CU VITEZA REGLABILA

- Pentru uz profesional in gelaterii, restaurante, bucatarii de hotel, pentru preparare inghetata, supe legume, piureuri, sosuri, umpluturi, maioneze, pasta tomate, pesto, etc.
- Motor ventilat
- Carcasa cu maner ergonomic, din material plastic rezistent
- Lama si ax din otel inoxidabil, lungime: 160 mm, Ø 25 mm
- Viteza: 4000 - 20000 rpm
- Greutate neta, inclusiv cu ax: aprox. 1,61 kg

cod	V	W	mm	lei
222140	230	270	140x76x(H)503	579,99

### TEL PENTRU BLENDER STICK 222140

- Contine 2 teluri din otel inoxidabil
- Atasare usoara si sigura la unitate motor

cod	mm	lei
222164	(L)185	379,99

222140



160 mm



**NOU**

222164



185 mm





design by  
Robert Bronwasser



### 6 PROGRAME PRESETATE

Eficienta crescuta.  
6 programe de procesare cu rotatii corespunzatoare.  
NU TREBUIE SA FII UN PROFESIONIST SA OBTII ACELEASI REZULTATE

### CORP ERGONOMIC SI USOR

Maner cu striatii pentru o priza FERMA.  
Unghiul de operare corect pentru OPERAREA COMODA + POZITIE NATURALA A DEGETULUI ARATATOR PE COMUTATOR

### SILENTIOS

Functionare silentioasa pentru BUCATARII DESCHISE Popular printre CHEFI



### HENDI BLEND BLENDER STICK

- Proiectat pentru bucatari de designerul Olandez Robert Bronwasser.
- Carcasa din plastic ABS si ax din otel inoxidabil.
- Lama in forma de cruce din otel inoxidabil cu acoperire din titan.
- Motor puternic de 250 W, 6 trepte cu afisaj LCD.
- Viteza maxima 13500 RPM.
- Potrivit pentru procesarea de la 1 l pana la 8 litri.

cod	V	W	mm	lei
222157	230	250	ø71x(H)450	315,99

PENTRU  
RECIPIENTE  
CU CAPACITATE  
INTRE  
1 SI 8 LITRI



### HD DESIGN

Rezistenta crescuta a corpului datorita materialului ABS TERPOLYMER + REZISTENTA la zgarieturi

### INTERVAL DE VITEZA IMPRESIONANT

de la 6,600 la 13,500 rpm  
REDUCE TIMPUL DE PREPARARE

222157

### LAME TRATATE CU TITANIUM

de 3 ori mai rezistente la tocare

VERSATIL  
Lungimea bratului 20 cm permite folosirea bolurilor mai mari





RECHARGEABLE  
BATTERY

ABS  
plastic

S.S.  
stainless steel

**NOU**

### BLENDER VERTICAL SMART PRESSURE WIRELESS

- Fabricat din otel inoxidabil satinat si ABS.
- Brat de amestecare detasabil cu o lama in forma de S.
- Functia Smart Pressure: cu cat butonul este apasat mai tare, cu atat creste viteza lamei - reglarea continua a vitezei asigura un control mai bun asupra procesului de amestecare.
- 5 trepte de viteza: de la 11.000 RPM (freza 1) la 16.000 RPM (freza 5).
- Fara fir si reincarcabil - cu o baterie incorporata: 2000 mAh, 150 W, 7,4 V.
- Indica 4 niveluri de incarcare a bateriei (100-75-50-25%).
- Timp de functionare: pana la 30 de minute cand este complet incarcat.
- Protectie: dupa 3 secunde fara activitate, lama este blocata.

cod	mm	lei
221419	ø65x(H)390	429,99



Indicator nivel baterie

Functia Smart Pressure intensitatea rotatiei lamei este reglata cu ajutorul unui buton, iar controlul precis al vitezei asigura un control mai bun asupra procesului de amestecare

Wireless, reincarcabil, cu baterie incorporata de 2000 mAh

Functie de siguranta: dupa 3 secunde de inactivitate, lama este blocata





Cu tel si suport de  
depozitare montat pe perete

224014



222393



224373



934012



250

## STICK BLENDER CU VITEZA VARIABILA CU TEL INCLUS HENDI 400

- Pentru utilizarea in gelaterie, restaurante, bucatarii de hotel, cafelele si companii de catering
- Este perfect pentru prepararea de ex. amestecuri de inghetata, supe de legume, piureuri, sosuri, umpluturi, maioneze, pasta de rosii, pesto, precum si frisca, creme si omlete - in functie de atasamentul folosit
- Carcasa sa este realizata din poliamida rezistenta de culoare albastra
- Bratele de lucru sunt realizate din otel inoxidabil AISI 304
- Bratul de amestecare are 350 mm lungime si poate fi scufundat pana la 200 mm
- Bratul de amestecare are 400 mm lungime si poate fi scufundat pana la 290 mm
- Potrivit pentru o capacitate de amestec de pana la 60 l
- Viteza bratului de amestecare: 2.500-11.000 rpm
- Viteza bratului de batare: 250-1500 rpm
- Setul include: un motor cu turatie variabila, bratul de amestecare, bratul de amestecare, un suport de depozitare montat pe perete

cod	V	W	mm	lei
224014	230	400	155x120x(H)790	2099,00

## SETARE: BLENDER VERTICAL 350 CU VITEZA VARIABILA + TEL + SUPORT MONTAT PE PERETE

- Capacitate de pana la 80 L.
- Setul include: brat de amestecare cu lungimea de 400 mm, ax de tel cu lungimea de 250 mm - fabricat din otel inoxidabil AISI304 si un suport montat pe perete.
- Diferite brate de amestecare pot fi achizitionate separat: 222232, 222225, 222256, 222263.

cod	V	W	mm	lei
222393	230	350	ø100x110	1209,00

## BLENDER STICK 250 W - CU VITEZA AJUSTABILA

- Versiune profesionala
- Carcasa din nailon armat cu fibra
- Brat si lama din otel inoxidabil
- Brida atasata inclusa (290 mm)
- Reglare usoara a vitezelor
- Usor de curatat
- Maner ergonomic
- Ax lung: 250 mm
- Potrivit pentru recipiente de pana la 20 de litri
- Buton pentru reglarea vitezei
- Viteza: 2500 - 15000 RPM
- Greutate 1,9 kg

cod	V	W	mm	lei
224373	230	250	ø75x(H)540	1679,00

## SUPORT DE DEPOZITARE MONTAT PE PERETE PENTRU BLENDER HENDI 250V

cod	lei
934012	138,99

## BLENDER STICK PROFI LINE 400 - CU VITEZA REGLABILA. INCLUS SUPORTUL PENTRU AGATARE

- Versiune profesionala
- Carcasa din nylon armat cu fibra
- Lama si tija din otel inoxidabil
- Usor de curatat
- Cu atasament pentru tel si suport de depozitare montat pe perete
- Control electronic
- 9 viteze, intre 2000 si 9000 rpm
- Capacitate pana la 80 litri
- Lungime tija 400 mm
- Greutate 4,75 kg

cod	V	W	mm	lei
224380	230	400	ø100x(H)765	2529,00



224380

## MIXER MANUAL CHEF PLUS, CU VITEZA VARIABILA, CU TEL SI CUTIT PENTRU OMOGENIZARE

- Pentru uz profesional in gelaterii, restaurante sau bucatarii hoteliere pentru prepararea amestecurilor de inghetata, supelor sau sosurilor
- Pachetul include un mixer cu viteza variabila, brat de amestecare, tel si cutit de omogenizare
- Carcasa din plastic
- Brat si lama din otel inoxidabil
- Brat de amestecare detasabil
- Motor ventilat care previne supraincalzirea
- Lungimi: brat de amestecare: 250 mm, brat de biciuire: 290 mm, cutit: 250 mm
- Potrivit pentru vase de pana la 20 de litri
- Viteza: 2500-15000 rpm
- Greutate: 1,3 kg.

cod	V	W	mm	lei
282298	230	250	ø75x(H)285	2659,00



282298

## MIXER MANUAL PENTRU INGHEATATA CU VITEZA VARIABILA SI CUTIT DE OMOGENIZARE

- Pentru uz profesional in gelaterii, restaurante sau bucatarii hoteliere pentru prepararea amestecurilor de inghetata etc.
- Pachetul include un mixer cu viteza variabila, brat de amestecare si cutit de omogenizare
- Carcasa din plastic
- Brat si lama din otel inoxidabil
- Brat de amestecare detasabil
- Motor ventilat care previne supraincalzirea
- Panou de control electronic (9 trepte)
- Lungimea bratului de amestecare si a cutitului: 400 mm
- Potrivit pentru vase de pana la 80 de litri
- Viteza: 2000-9000 rpm
- Max. viteza: 15000 rpm
- Greutate: 2,4 kg

cod	V	W	mm	lei
282311	230	400	ø100x(H)350	2509,00



282311





## MIXERE DE MANA SAMMIC

- Pentru mixarea diverselor ingrediente in acelasi timp, in recipiente de la 10 la 250 litri
- Cutit cu trei lame, din otel inoxidabil calit, cu muchii de taiere durabile
- Capac de protectie pentru cutit, cu un diametru de la 65 pana la 123 mm

 **sammic**

- Marcare clara a nivelului maxim de imersie
- Carcasa ergonomica a motorului
- Viteza constanta 12.000 RPM sau viteza reglabila intr-un interval de la 1.500 la 12.000 sau chiar pana la 15.000 rpm
- Partea palmei acoperita cu material antiaderent



### Robust

- creste eficienta: asigura pe termen lung functionarea fara supraincalzirea carcasei.
- echipat cu un motor puternic care a fost supus celor mai exigente teste de utilizator
- geometria atenta a carcasei, conceputa pentru a preveni rostogolirea dispozitivului
- usor de curatat: bratul poate fi spalat sub robinet sau in masina de spalat vase

### Click-on-arm:

sistem de prindere cu click a bratului

### All-in-one - dispozitive universale pentru profesioniști

- Cutit profesional cu lama Y si cu trei lame de otel - eficiente si fiabile
- Vario-speed: viteza variabila pentru rezultate perfecte
- Ideal pentru functionare continua

### Confort maxim pentru utilizator

- design compact: convenabil si usor de utilizat
- carcasa exteriora fabricata din doua materiale pentru a asigura o prindere ergonomica. Prindere anti-alunecare si inclinare optima a manerul pentru a minimiza oboseala
- operare intuitiva: foarte usor de utilizat. In plus, indicatorul luminos pentru conectarea dispozitivului la rețeaua electrica garanteaza siguranta operatorului, indicatorul luminos se aprinde imediat ce mixerul este conectat la sursa de alimentare

pentru recipiente

de la 10 la 250 litri

viteza de rotatie

de la 1500 la 15000 RPM

Pentru  
recipiente  
de la 10  
la 250 litri

Protectie  
stropire





## ACCESORII

cod	pentru	brat	lungime (mm)	adancime max. (mm)	capacitate max recipient (l)	pentru baterie oua	viteza (rpm)	lei
3030613	3030618	mixare	192	155				<b>399,99</b>
3030624	3030618	mixare	223	185	10			<b>431,99</b>
3030638	3030625	mixare	250	200	12			<b>526,99</b>
3030640	3030625	mixare	300	250	15			<b>642,99</b>
3030641	3030625	cu teluri	300		15	2 - 30	200 - 1800	<b>982,99</b>
3030653	3030672	mixare	306	260	30			<b>647,99</b>
3030655	3030672	mixare	366	320	45			<b>670,99</b>
3030657	3030672	mixare	420	375	60			<b>763,99</b>
3030670	3030672	cu teluri	300		30	2 - 50	200 - 1800	<b>927,99</b>
3030685	3030684	mixare	419	370	80			<b>796,99</b>
3030687	3030684	mixare	519	470	120			<b>867,99</b>
3030696	3030684	cu teluri	300					<b>1499,00</b>
3030856	3030717	mixare	540	490	200			<b>1529,00</b>
3030855	3030717	mixare	630	580	250			<b>1719,00</b>

NOU



cod	3030618	3030625	3030634	3030672
	blender stick cu brat mixare XM-12	blender stick cu brat mixare XM-21	blender stick cu brat mixare si brat cu teluri MB-21	blender stick cu brat mixare XM-31
accessorii	brat normal	brat normal	brat mixare brat cu teluri	brat normal
pentru vase cu capacitate maxima	10 l	12 l	12 l pana la 30 oua	30 l
lungimea totala	448 mm	514 mm	514 mm	614 mm
	223 mm	250 mm	250 mm	306 mm
adancime	[adancime max. pana la aprox 185 mm]	[adancime max. pana la aprox 200 mm]	[adancime max. pana la aprox 200 mm]	[adancime max. pana la aprox 260 mm]
	variabila	variabila	variabila	fixa
viteza	1 500 - 15 000 rpm	1 500 - 15 000 rpm	1 500 - 15 000 rpm	12 000 rpm
diametru cutit	65 mm	82 mm	82 mm	87 mm
putere/alimentare	240 W/230 V	300 W/230 V	300 W/230 V	400 W/230 V
greutate	1,4 kg	2,3 kg		3,34 kg
nivel zgomot	<80 dB	<80 dB	<80 dB	<80 dB
lei	<b>1049,00</b>	<b>1329,00</b>	<b>2099,00</b>	<b>1909,00</b>



3030676	3030684	3030691	3030717	3030718
blender stick cu brat mixare si brat cu teluri MB-31	blender stick cu brat mixare XM-51	blender stick cu brat mixare si brat cu teluri MB-51	blender stick cu brat mixare XM-71	blender stick cu brat mixare XM-72
brat mixare brat cu teluri	brat normal	brat mixare brat cu teluri	brat normal	brat normal
30 l pana la 50 oua	80 l	80 l pana la 60 oua	200 l	250 l
614 mm	760 mm	760 mm	880 mm	970 mm
306 mm (adancime max. pana la aprox 260 mm)	420 mm (adancime max. pana la aprox 370 mm)	420 mm (adancime max. pana la aprox 370 mm)	540 mm (adancime max. pana la aprox 490 mm)	630 mm (adancime max. pana la aprox 580 mm)
variabila 1 500 - 12 000 rpm	fixa 12 000 rpm	variabila 1 500 - 12 000 rpm	fixa 12 000 rpm	fixa 12 000 rpm
98 mm	98 mm	98 mm	123 mm	123 mm
400 W/230 V	570 W/230 V	570 W/230 V	750 W/230 V	750 W/230 V
	4,65 kg		4,57 kg	
<80 dB	<80 dB	<80 dB	<80 dB	<80 dB
<b>2879,00</b>	<b>2109,00</b>	<b>3009,00</b>	<b>3219,00</b>	<b>3299,00</b>





### Protectie si siguranta in folosire

- Protectie la supraincalzire
- Capac retractabil
- Brat de sustinere neconductiv
- Picioare antiderapante
- Ghidaj de balansare cu opritoare
- Siguranta de suprasarcina
- Comutator iluminat
- Marcaj HOT vizibil

### Auto Lift

Un sistem de suporturi pentru ridicarea mai usoara a placi de incalzire. Eficienta crescuta.

### Design robust

Cadrul este din material rezistent la acizi, otel cu o grosime de peste 2 mm. Design solid si robust.

### Suprafata de etansare antiaderenta

Previne lipirea tuturor tipurilor de pelicule de suprafata. Sigilare rapida, dureaza 1-3 secunde (in functie de grosimea foliei).

### Absorbant de presiune

Reglare usoara a fortei de presiune pe marginile placii de incalzire. Previne ruperea ambalajului. Elimina micro-golurile si scurgerile.

### Sistem de incalzire puternic si rapid

Incalzitoarele puternice reduc timpul de incalzire. Dureaza doar 8-10 minute (in functie la temperatura setata). Temperatura uniforma pe intreaga suprafata de etansare. Izolarea termica reduce pierderea de caldura.

### Sistem taiere folie

cu un taietor retractabil automat cu 133 de dinti ascutiti. Foarte util pentru pelicule groase. Folia este taiata chiar si in spate recipientul. Sigilare intr-o banda speciala bazat pe tehnologia AIR-CUT

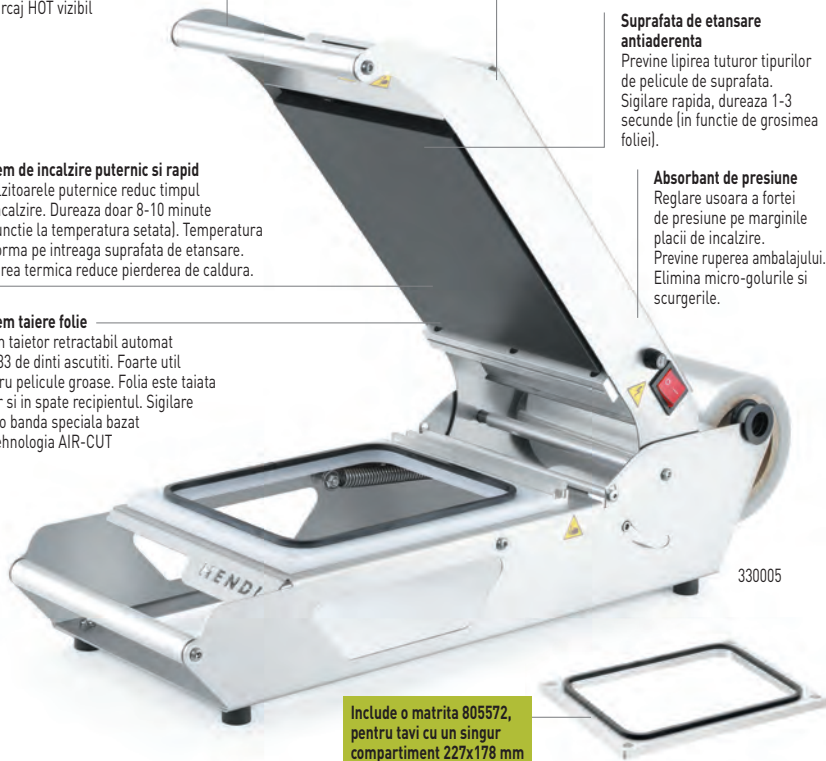

### Intrtinere/Zona de siguranta

Baza cadrului este izolata de temperaturi ridicate si tensiunea electrica. Materiale de inalta calitate si design fara sudura pentru curatarea rapida a partii inferioare a corpului, fara a opri dispozitivul.



### Regulator de temperatura

Regulator de temperatura 50-210°C. Pentru ajustarea precisa a lipirii, rezistenta pentru o gama larga de ambalaje si folii de etansare.



### Sistem alimentare folie sigilare cu intinzator

Dispozitiv versatil pentru diferite latimi de role - max. 187 mm. JUMBO ruleaza pana la 170 mm in diametru. Intinzatorul asigura uniformitatea in pozitionarea foliei, previne derularea excesiva.

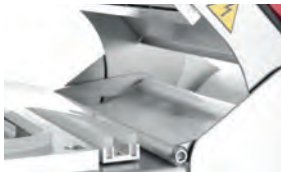



## DISPOZITIV DE SIGILARE TAVA COMPACT

- Constructie realizata din otel inoxidabil.
- Echipat cu un capac cu mecanism cu arc pentru o deschidere usoara si sigura.
- Maner izolat fabricat din plastic rezistent la deteriorare.
- Ghilotina automata cu lama protejata de o husa special conceputa; taierea are loc imediat in spatele recipientului sigilat, intr-o banda speciala (tehnologie de taiere cu aer).
- Picioare anti-alunecare care protejeaza blatul de zgarieturi.
- Suprafata de etansare are invelis de titan care previne lipirea peliculei si permite o etansare rapida in 1-3 secunde (in functie de grosimea peliculei).
- Amortizorul de presiune asigura o etansare etansa si previne strivirea ambalajelor.

- LED-uri codificate pe culori pentru monitorizarea performantei.
- Blocare la supraincalzire, protectie la supraincalzire, comutator de siguranta iluminat.
- Durata de incalzire dupa pornire in modul complet de functionare - aproximativ 8-10 minute.
- Etansare tavi pana la: 235x190x(H)155 mm si cupe pana la: (H)170 mm.
- Dimensiune maxima a rolei de film: latime 187 mm, ø170 mm - film comercializat separat (cod: 970720).
- Echipat cu matrita de aluminiu pentru recipiente de 227x178 mm (cod: 805572), fara separator.

cod	V	W	mm	lei
330005	230	700	582x285x(H)185	2409,00

## FORMA TIP MATRICE PENTRU ETANSARE TAVILOR

- Mult spatii pentru gratar, pentru a se potrivi cu caserolele panini italiene originale si pentru a le conferi benzilor maro caracteristice.
- Atat gratarul superior cat si cel inferior sunt canelate.
- Greutate neta: 25 kg



forma	cod	tip	lei
	805572	pentru un recipient cu un compartiment 227x178 mm	459,99
	805589	pentru doua recipiente 178x113 mm	459,99
	805596	pentru un recipient cu doua compartimente 227x178 mm	459,99
	805619	pentru recipient de supa, mare ø165 mm	459,99
	805626	pentru un recipient cu trei compartimente 227x178 mm	459,99

forma	cod	tip	lei
	805633	pentru doua recipiente de supa ø115 mm	459,99
	805640	pentru un recipient cu doua compartimente 227x178 mm	459,99
	805657	pentru un recipient cu un compartiment 178x113 mm + pentru un recipient de supa ø115 mm	459,99
	805664	pentru un recipient cu un compartiment 187x137 mm	459,99

## FOLIE DE SIGILARE/CPP PEEL 12/40.4

- Destinat pentru ambalarea tavilor alimentare PET 12 / CPP 40.
- Stratul PEEL care faciliteaza ruperea filmului sigilat.
- Dimensiuni film: latime: 18,5 cm, lungime: 250 m.
- Diametru rola: ø15 cm.
- Greutate rola film: aprox. 2,9 kg.

cod	lei
970720	115,99



970720

# arktic

PROFESSIONAL REFRIGERATION



RACIRE SI CONGELARE



976722

Matricea PE inclusă  
pentru tava fără divizare  
227x178 mm GRATUIT



## DISPOZITIV MANUAL PENTRU ETANSAREA TAVILOR

- Destinat ambalării alimentelor și a altor produse în tavi de plastic de unică folosință, potrivite pentru alimente calde sau reci.
- Sigilează o varietate de tavi, matricea tavii poate fi comutată pentru diferite dimensiuni de matrice.
- Poate sigila tavile la o dimensiune de 235x190x(H)155 mm și cupele la o înălțime de (H) 170 mm.
- Livrat cu o matrice din aliaj de aluminiu pentru tavi de 227x178 mm (805572), fără divizare.
- Alte dimensiuni sunt disponibile separat.
- Construcție durabilă din oțel inoxidabil.
- Manerul ergonomic este fabricat din plastic rezistent la deteriorări.
- Placa de etansare este prevăzută cu un mecanism cu arc, facilitând deschiderea după etansare.
- Temperatura de etansare poate fi setată de la 50° până la 210 °C.
- Echipat cu încălzitoare puternice, timpul de încălzire este de doar 8-10 minute și timpul de etansare este de doar 1-3 secunde.
- Placa de etansare este acoperită cu un strat antiaderent, ceea ce împiedică lipirea foliei după etansare.
- Placa de etansare acționează ca un amortizor de presiune.

- La blocarea plăcii de etansare, presiunea este răspândită uniform pe marginea containerului, prevenind spargerea și eliminând microfisurile, reducând scurgerile.
- Cuit retractabil incorporabil, taie folia chiar în spatele containerului sigilat.
- Distribuitorul de folie este universal pentru role cu o lățime de până la 187 mm, se pot potrivi role cu o rezistență maximă diametru de 170 mm.
- Echipat cu un dispozitiv de întindere a foliei, asigurând o folie bine sigilată fără bucle și pliuri.
- Foarte sigur datorită utilizării unei siguranțe de suprasarcină, protecției la supraîncălzire și comutatorului iluminat din spate.
- Picioarele antiderapante sunt foarte stabile și protejează blatul de la zgăriere.
- Cu cablu de alimentare detașabil de 1,5 m cu priză la pamant.
- Greutate netă: 10 kg.

cod	V	W	mm	lei
976722	230	700	247x637x(H)258	3089,00

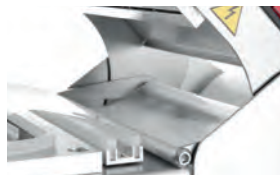



### MASINA DE AMBALAT SOUS-VIDE BUDGET LINE

- Doua tipuri de etansare a pungilor din care puteti alege
- Posibilitatea de a folosi pungii la rola
- Se foloseste numai cu pungii gofrate de max 310 mm latime
- Latimea barei de etansare 2 mm
- Procesul rapid de lipire impiedica aspirarea lichidelor
- Capacitate pompa: 11 l/min
- Bara de etansare de pe capacul ridicat reduce riscul
- arsurilor in timpul functionarii si faciliteaza curatarea dispozitivului
- Confort ridicat de lucru datorita emisilor reduse de zgomot
- Greutate: 1,74 kg



975350

cod	banda de etansare (mm)	V	W	mm	lei
975350	310	230	100	390x160x(H)92	319,99

## APARAT DE VIDAT PENTRU ROLE DE PUNGI VACUUM BUDGET LINE

- Carcasa ABS, design-ul special impiedica intrarea lichidului in pompa.
- Recipient incorporat pentru rola de pungi vacuum.
- Doar pentru pungi de vidat gofrate cu latimea maxima de 300 mm.
- Posibilitatea alegeri a doua durate de etansare si a doua niveluri de vidare.
- Capacitatea pompei: 6,5 l/min  $\pm$  15%.
- Latimea barei de etansare este de 2,2 mm.
- Greutate: aprox. 2 kg.

cod	banda de etansare (mm)	V	W	mm	lei
201626	310	230	100	385x205x(H)95	374,99



201626

ABS  
plastic



975374

## MASINA AMBALARE VACUUM KITCHEN LINE

- Pentru ambalarea produselor alimentare si nealimentare, cu exceptia lichidelor.
- Poate fi folosit cu dispozitivul pentru role 970638.
- Carcasa din otel inoxidabil.
- Garnitura capacului garanteaza o etansare etansa in timpul functionarii.
- Panou de control usor de utilizat.
- Functia de reglare a cronometrului invers: 0-6 s
- Cu functie de marinare.
- Cu modul de generare a pulsului de vid.
- Butoane de pornire rapida pentru vid si etansare pe maner.
- Oprire automata dupa 10 minute de inactivitate.
- Pompa de vibratii.
- Capacitate pompa: 16 l/min.
- Greutate neta: 5 kg.
- Masina de ambalat in vid nu este dedicata functionarii continue.
- Pentru a fi folosit pungi gofrate.

cod	banda de etansare (mm)	V	W	mm	lei
975374	410	230	550	570x263x(H)150	1149,00



970638

## DISPOZITIV ROLE PUNGI PENTRU MASINA AMBALARE VACUUM KITCHEN LINE 975374

- Poate fi anexat masinii de ambalat vacuum Kitchen Line 975374 sau poate functiona ca produs de sine stator cu alt aparat vacuum
- Echipat cu un cutit detasabil pentru a taia exact dimensiunea dorita a pungii
- Dimensiuni interne: 412x101x(H)101 mm
- Pentru role cu dimensiuni maxime  $\phi$ 100x400 mm
- Baza din ABS
- Capac din policarbonat transparent pentru control usor al rolei

cod	mm	lei
970638	487x122x(H)107	89,99



**MASINI DE AMBALAT SUB VID, TIP BANDA**

- Dispozitivul este destinat utilizarii in magazine, restaurante si hoteluri.
- Pentru sigilarea ambalajelor si pungilor de gatire mici.
- Se foloseste numai cu pungi gofrate.
- Control automat.
- Etansare programabila.
- Pompa de vibratii cu o capacitate de 13 l/min (297384), 21 l/min (297377).
- Maner ergonomic si solid pentru deschiderea usoara a capacului.
- Carcasa din otel inoxidabil.
- Greutate: 6 kg.



297384

cod	banda de etansare (mm)	V	W	mm	lei
297384	330	230	380	385x300x(H)170	1699,00



975336

**MASINA AMBALARE VACUUM KITCHEN LINE**

- Constructie din otel inoxidabil
- Pompa profesionala de vacuum
- Operare semi-automata
- Banda de sigilare acoperita cu teflon
- Pompa vacuum: 20 lt/min
- Folosire cu pungi speciale

cod	banda de etansare (mm)	V	W	mm	lei
975336	350	230	250	370x260x(H)130	1799,00



970362

**MASINA AMBALARE VACUUM PROFI LINE**

- Constructie otel inoxidabil
- Pompa de vid profesionala si manometru
- Operare automata sau operare manuala
- Display digital
- Timp de sigilare reglabil
- Banda de etansare acoperita cu teflon
- Capacitate pompa 20 lt/min
- Folosire doar cu pungi vacuum gofrate



Vezi filmul

cod	banda de etansare (mm)	V	W	mm	lei
970362	350	230	250	383x293x(H)175	2079,00



971444



GATIRE



DEPOZITARE

**PUNGI VACUUM GOFRATE - 100 BUCATI**

- 2 straturi, strat interior 60 µm polietilena potrivit pentru contactul cu alimentele, strat exterior 15 µm Poliamida (nailon).
- Grosimea totala este de 75 µm.
- Materialele folosite actioneaza ca un filtru UV.
- Imbunatateste debitul de aer din ambalaj in timpul procesului de ambalare in vid.
- Pungile pot fi folosite la temperaturi de la -20° pana la 100°C.
- Potrivit pentru masinile de ambalat in camera si in vid.

cod	ambalat pe	mm	lei
971390	100	150x250	<b>34,99</b>
971420	100	150x400	<b>50,99</b>
971406	100	200x300	<b>49,99</b>
971437	100	250x350	<b>68,99</b>
971413	100	300x400	<b>99,99</b>
971444	2 rulouri	200x6000	<b>29,99</b>
971451	2 rulouri	300x6000	<b>34,99</b>



DEPOZITARE

**SACI DE SIGILARE IN VID, IN RELIEF, PENTRU DEPOZITAREA ALIMENTELOR**

- Pot fi utilizate la temperaturi de la -40°C la +40°C
- Gofreaea in forma de diamant faciliteaza extragerea aerului si crearea vidului
- Fara Bisfenol A (BPA)

cod	ambalat pe	mm	lei
297414	100	150x250	<b>36,99</b>
297421	100	150x400	<b>49,99</b>
297438	100	200x300	<b>49,99</b>
297445	100	250x350	<b>67,99</b>
297452	100	300x400	<b>96,99</b>
297469	2 rulouri	200x6000	<b>34,99</b>
297476	2 rulouri	300x6000	<b>54,99</b>



DEPOZITARE



GATIRE



DEPOZITARE

**PUNGI AMBALARE VACUUM - 100 BUCATI**

- 2 straturi, strat interior realizat din polietilena potrivit pentru contactul cu alimentele, strat exterior din poliamida (nailon).
- Grosimea totala este de 65 µm.
- Potrivit pentru masinile de ambalare in vid in camera.
- Nu este potrivit pentru gatit sous vide.

cod	ambalat pe	mm	lei
970607	100	200x140	<b>17,99</b>
970386	100	230x160	<b>23,99</b>
970614	100	300x200	<b>34,99</b>
970393	100	350x250	<b>47,99</b>
970621	100	400x300	<b>61,99</b>

**PUNGI VACUUM PENTRU GATIT - 100 BUCATI**

- Potrivit pentru gatitul sous vide.
- 2 straturi, strat interior 60 µm polietilena potrivit pentru contactul cu alimentele, strat exterior 15 µm Poliamida (nailon).
- Grosimea totala este de 75 µm.
- Materialele folosite actioneaza ca un filtru UV.
- Pungile pot fi utilizate la temperaturi de la -20° pana la 110°C.
- Potrivit pentru masinile de ambalare in vid in camera.

cod	ambalat pe	mm	lei
971369	100	150x200	<b>24,99</b>
971345	100	150x250	<b>34,99</b>
971376	100	200x300	<b>48,99</b>
971352	100	250x350	<b>69,99</b>
971383	100	300x400	<b>83,99</b>



## MASINA AMBALARE VACUUM KITCHEN LINE - CU CAMERA

- Pentru uz profesional in gastronomie si sectoare industriale
- Constructie durabila - carcasa si camera din otel inoxidabil de inalta calitate
- Capacul transparent din plastic dur ABS de inalta calitate va permite sa controlati procesul de ambalare
- Capacul convex va permite sa impachetati portii mari
- Timp de etansare a pungii: 0-6 s
- 6 niveluri de vid din care sa alegeți
- Functie de marinare: posibilitate de a utiliza pana la 11 cicluri de aspiratie si lasare aer in sac (un ciclu de 9 min); datorita vidului, marinada patrunde mai repede in produs, ceea ce accelereaza semnificativ procesul in sine
- Pornirea automata a ciclului de ambalare prin inchiderea capacului superior
- Pompa rotativa profesionala cu eficienta ridicata
- Masina de ambalat este proiectata pentru functionare continua

## MASINA AMBALARE VACUUM CU CAMERA PROFI LINE

- Pentru uz profesional in gastronomie si sectoare industriale
- Pentru ambalarea produselor alimentare si tehnice, inclusiv cele cu continut mare de apa
- Constructie durabila - carcasa si camera din otel inoxidabil AISI 304 de inalta calitate
- Capacul transparent din plastic dur ABS de inalta calitate va permite sa controlati procesul de ambalare
- Capacul convex si cavitataea din partea inferioara a camerei [975251] permit impachetarea portiunilor mari
- Garnitura in forma de V cu un coeficient ridicat de etansitate
- Indicatoroare clare - afisaj digital si cadran - permit determinarea precisa a momentului atingerii nivelului de vid necesar in camera de ambalare
- Timp de functionare reglabil al pompei pentru a obtine nivelul adecvat de vid in intervalul 0-99 s
- Timp de sudare reglabil in intervalul 0-3,5 s
- Nivelul de racire al pompei reglabil in intervalul 0-9,9 s
- Pornirea automata a ciclului de ambalare prin inchiderea capacului camerei de ambalare
- Pompa de ulei pentru un ciclu de ambalare scurt si foarte eficient



Panoul de comanda

Design rezistent - carcasa din otel inoxidabil

975398



Panoul de comanda

Design rezistent - carcasa din otel inoxidabil

975251

cod	975398	975251	975268	975275
dimensiuni	429x359x(H)345 mm	330x480x(H)360 mm	370x480x(H)435 mm	425x560x(H)460 mm
dimensiuni camera	350x300x(H)110 mm	280x385x(H)130 mm	320x370x(H)185 mm	370x450x(H)220 mm
banda sigilare cu lungime	295 mm	260 mm	300 mm	350 mm
capacitate pompa	77 U/min	167 U/min	133 U/min	333 U/min
putere/tensiune	630 W/230 V	370 W/230 V	370 W/230 V	750 W/230 V
greutate	24,4 kg	36 kg	38 kg	62 kg
lei	3149,00	4109,00	4469,00	4799,00

## MASINA DE AMBALAT IN VID

- Pentru utilizare profesionala in industria de catering si in alte industrii
- Pentru ambalarea produselor alimentare si a produselor tehnice, inclusiv a celor cu un continut ridicat de apa
- Design durabil - carcasa si camera fabricate din otel inoxidabil AISI 304 de inalta calitate
- Capacul transparent realizat din plastic ABS durabil de inalta calitate face posibil controlul procesului de ambalare
- Capacul convex si fundul concav fac posibila ambalarea de portii mari
- Garnitura din capac are o rata de scurgere reduca
- Indicatorii clari (afisaj digital si comparator) fac posibila identificarea exacta a momentului in care este atins nivelul de vid necesar in camera masinii de ambalat
- Timp de vid reglabil 5-90 s
- Timpul reglabil de sigilare a pungilor avanseaza la fiecare 0,5 s pana la 6 s
- Functia de marinare cu timp reglabil de la 9 la 99 de minute (durata unui ciclu: 9 min): posibilitatea de a programa 11 cicluri de extragere si eliberare a aerului in punga; datorita presiunii negative, marinada patrunde mai repede in produs, ceea ce accelereaza semnificativ intregul proces
- Ciclul de ambalare incepe automat atunci cand capacul superior este inchis
- Pompa de ulei asigura un ciclu de ambalare scurt si foarte eficient
- Pentru a fi utilizat cu pungi netede si gofrate



Vezi filmul



201428

Design rezistent -  
carcasa din otel inoxidabil

cod	201428	201435	201442
dimensiuni	330x480x(H)356 mm	359x425x(H)356 mm	505x567x(H)465 mm
dimensiuni camera	280x393x(H)80 mm	300x350x(H)80 mm	425x457x(H)100 mm
banda sigilare cu lungime	260 mm	300 mm	410 mm
capacitate pompa	8 m <sup>3</sup> /h - 133,3 l/min	8 m <sup>3</sup> /h - 133,3 l/min	20 m <sup>3</sup> /h - 333,3 l/min
putere/tensiune	1000 W/230 V	950 W/230 V	1100 W/230 V
greutate	24 kg	25,2 kg	59 kg
lei	<b>3869,00</b>	<b>3759,00</b>	<b>6699,00</b>

Pret catalog fara TVA

HENDI



## PUNGI VACUUM PENTRU GATIT - 100 BUCATI

- Potrivit pentru gatirea sous vide.
- 2 straturi, strat interior 60 µm polietilena potrivit pentru contactul cu alimentele, strat exterior 15 µm Poliamida (nailon).
- Grosimea totala este de 75 µm.
- Materialele folosite actioneaza ca un filtru UV.
- Pungile pot fi utilizate la temperaturi de la -20° pana la 110 °C.
- Potrivit pentru masinile de ambalare in vid in camera.

cod	ambalat pe	mm	lei
971369	100	150x200	<b>24,99</b>
971345	100	150x250	<b>34,99</b>
971376	100	200x300	<b>48,99</b>
971352	100	250x350	<b>69,99</b>
971383	100	300x400	<b>83,99</b>



## PUNGI AMBALARE VACUUM - 100 BUCATI

- 2 straturi, strat interior realizat din polietilena potrivit pentru contactul cu alimente, strat exterior din poliamida (nailon).
- Grosimea totala este de 65 µm.
- Potrivit pentru masinile de ambalare in vid in camera.
- Nu este potrivit pentru gatit sous vide.

cod	ambalat pe	mm	lei
970607	100	200x140	<b>17,99</b>
970386	100	230x160	<b>23,99</b>
970614	100	300x200	<b>34,99</b>
970393	100	350x250	<b>47,99</b>
970621	100	400x300	<b>61,99</b>

265

## MASINA DE VIDAT CU CAMERA - SERIA SE

- Produsele alimentare ambalate in vid isi pastreaza prospetimea si sunt perfect protejate de factori externi (de exemplu, murdarie, umiditate). In plus extragerea aerului face posibila reducerea volumului volumului unor produse.
- Functia de sigilare a pungilor fara aspiratie de aer face posibila sigilarea ermetica a produselor delicate fara a le modifica structura sau a produselor cu forma neregulata fara riscul de deformare.
- Generarea treptata a vidului - pentru utilizare cu produse poroase, carne prelucrata, produse emulsionate amestecuri cu bule de aer captive.
- Ambalare in vid extern (Vac-Norm) - acest proces proces necesita recipiente speciale pentru catering recipiente de catering. Pentru a utiliza functia Vac-Norm, este necesar pentru a utiliza functia Vac-Norm, este necesara achizitionarea unui Vac-Norm extern, constand intr-un furtun si un conector la camera aparatului de vidat.
- Ulei uscat: Uscarea pompei - aceasta functie permite intretinerea de unei calitati ridicate a uleiului prin eliminarea excesului de umiditate, astfel incat masina sa poata atinge cel mai inalt nivel de generare a vidului.
- Modul de marinare - aceasta functie este utilizata pentru a repeta ciclul de generare a vidului, permitand marinarea optima a alimentelor in cel mai scurt timp posibil.
- Aparatele de vidat sunt fabricate din materiale de cea mai buna calitate, ceea ce le face durabile si rezistente la factorii externi
- Capacul transparent permite observarea intregului proces de ambalare procesul de ambalare.
- Programul de vidare controlat de senzori este conceput pentru produsele cu texturi delicate.
- Masinile sunt echipate cu o bara de sigilare dubla pentru a asigura procesul de sigilare.



### Bare sigilare

echipat cu incalzitoare curbate pentru a indeparta reziduurile de produs si pentru a garanta etanseitatea sigilarii



### Panou de control digital, intuitiv



Toate modelele sunt echipate cu o pompa Busch care garanteaza eficienta si economia de energie



1140642



1140628



1140680

### MASINILE DE AMBALAT IN VID SERIA 200, 300, 400 SI 500

cod	1141080	1140628	1140636	1141142
model	SE-208	SE-310	SE-416	SE-520 CC
dimensiuni exteriore	337x431x(H)307 mm	384x465x(H)403 mm	484x529x(H)448 mm	634x552x(H)513 mm
dimensiuni camera	288x334x(H)111 mm	330x360x(H)155 mm	430x415x(H)180 mm	568x430x(H)215 mm
lungime banda	280 mm	320 mm	420 mm	420+420 mm
capacitate pompa BUSCH	8 m <sup>3</sup> /h	10 m <sup>3</sup> /h	16 m <sup>3</sup> /h	20 m <sup>3</sup> /h
presiune de aspirare	2 mbar	2 mbar	2 mbar	2 mbar
putere/alimentare	370 W/230 V	370 W/230 V	550 W/230 V	750 W/230 V
greutate	26 kg	34 kg	65 kg	76 kg
lei	<b>10549,00</b>	<b>12999,00</b>	<b>16349,00</b>	<b>24099,00</b>

### MASINI DE AMBALAT CU VID SERIA SE 600

cod	1140650	1140651	1140662	1140663
model	SE-604	SE-604 CC	SE-606	SE-606 CC
dimensiuni exteriore	740x566x(H)997 mm	740x566x(H)997 mm	740x566x(H)997 mm	740x566x(H)997 mm
dimensiuni camera	672x481x(H)200 mm	672x481x(H)200 mm	672x481x(H)200 mm	672x481x(H)200 mm
lungime banda	413+656 mm	465+465 mm	413+656 mm	465+465 mm
capacitate pompa BUSCH	40 m <sup>3</sup> /h	40 m <sup>3</sup> /h	63 m <sup>3</sup> /h	63 m <sup>3</sup> /h
presiune de aspirare	0,5 mbar	0,5 mbar	0,5 mbar	0,5 mbar
putere/alimentare	1100 W/230 lub 400V	1100 W/230 lub 400V	1500 W/230 lub 400V	1500 W/230 lub 400V
greutate	145 kg	145 kg	159 kg	159 kg
lei	<b>35999,00</b>	<b>35999,00</b>	<b>37799,00</b>	<b>37799,00</b>

### MASINI DE AMBALAT IN VID SE SERIES 800

cod	1140680	1140681	1140682	1140696	1140697	1140698
model	SE-806	SE-806 CC	SE-806 LL	SE-810	SE-810 CC	SE-810 LL
dimensiuni exteriore	960x757x(H)998 mm	960x757x(H)998 mm	960x757x(H)998 mm	960x757x(H)998 mm	960x757x(H)998 mm	960x757x(H)998 mm
dimensiuni camera	864x603x(H)215 mm	864x603x(H)215 mm	864x603x(H)215 mm	864x603x(H)215 mm	864x603x(H)215 mm	864x603x(H)215 mm
lungime banda	530+848 mm	581+581 mm	848+848 mm	530+848 mm	581+581 mm	848+848 mm
capacitate pompa BUSCH	63 m <sup>3</sup> /h	63 m <sup>3</sup> /h	63 m <sup>3</sup> /h	100 m <sup>3</sup> /h	100 m <sup>3</sup> /h	100 m <sup>3</sup> /h
presiune de aspirare	0,5 mbar	0,5 mbar	0,5 mbar	0,5 mbar	0,5 mbar	0,5 mbar
putere/alimentare	1500 W/ 230 sau 400V	1500 W/ 230 sau 400V	1500 W/ 230 sau 400V	2200 W/ 230 sau 400V	2200 W/ 230 sau 400V	2200 W/ 230 sau 400V
greutate	232 kg	232 kg	232 kg	250 kg	250 kg	250 kg
lei	<b>46499,00</b>	<b>46499,00</b>	<b>46899,00</b>	<b>54649,00</b>	<b>54649,00</b>	<b>55049,00</b>



## MASINA DE AMBALARE VACUUM SAMMIC

- Pentru ambalarea profesionala in vid a produselor alimentare
- Camera fabricata din otel rezistent
- Rezistenta crescuta la factori externi
- Capac transparent
- Banda de sigilare dubla
- Putere adecvata, pompa de vidare eficienta si o camera de vidare mare pentru ambalare rabida a produselor de diferite dimensiuni
- Functie fara aspirare pentru produse delicate, fara a le modifica structura
- Vidare treptata adaptata pentru produse poroase, carne aplatazata, emulsii aerate
- Uscarea uleiului - o functie care mentine cea mai inalta calitate a uleiului, inlaturand umiditatea in exces
- Posibilitatea de a sigila pungi cu continut marinat, pastrandu-le proprietatile si volumul - ambalarea in vid are loc fara a extrage aerul

- Ambalare in siguranta a produselor cu o cantitate mare de apa in compozitie - sistemul blocheaza aspirarea fluidelor
- Panou de control digital color
- Butoane luminate rezistente la zgarieturi
- 25 de programe de ambalare vacuum
- Conexiune Bluetooth cu aplicatia mobila
- Dotat cu un port pentru imprimanta
- La cerere:
  - Sistem de printare a etichetelor cu posibilitatea de a conecta imprimanta cu adeziv rezistent la inghet (input text prin aplicatie)
  - Kit extern Vac-Norm pentru ambalare in containere speciale folosind aspiratia automata a aerului
  - Sistem de injectie a gazului care permite ambalarea in vid fara a avea oxigen sau aburi in camera de vidare, protejand produsul de agenti externi
  - Sistem special de vidare a pungilor realizate din materiale mai groase sau metalizate



1141102



NOU

## MASINILE DE AMBALAT IN VID SU-300, 400 SI 500 CU PORT PENTRU IMPRIMANTA SI BLUETOOTH

cod	1140732	1140774	1141102
model	SU-316P	SU-420P	SU-520P CC
dimensiuni exterioare	384x465x(H)403 mm	484x529x(H)448 mm	634x552x(H)513 mm
dimensiuni camera	330x360x(H)155 mm	430x415x(H)180 mm	568x430x(H)215 mm
lungime banda	320 mm	420 mm	420+420 mm
capacitate pompa BUSCH	16 m <sup>3</sup> /h	20 m <sup>3</sup> /h	20 m <sup>3</sup> /h
presiune de aspirare	2 mbar	2 mbar	2 mbar
putere/alimentare	320 W/ 230 V	750 W/ 230 V	750 W/ 230 V
greutate	35 kg	70 kg	80 kg
lei	<b>16049,00</b>	<b>19399,00</b>	<b>25849,00</b>



Toate modelele sunt echipate cu o pompa Busch care garanteaza eficienta si economia de energie



1140814



1140820

sammic

NOU

NSF

**MASINILE DE AMBALAT IN VID SU-600 CU PORT PENTRU IMPRIMANTA SI BLUETOOTH**

cod	1140814	1140820	1140838	1140848
model	SU-604P	SU-604P CC	SU-606P	SU-606P CC
dimensiuni exterioare	740x566x(H)997 mm	740x566x(H)997 mm	740x566x(H)997 mm	566x740x(H)997 mm
dimensiuni camera	672x481(H)200 mm	672x481(H)200 mm	672x481x(H)200 mm	672x481x(H)200 mm
lungime banda	413+656 mm	465+465 mm	413+656 mm	465x465 mm
capacitate pompa BUSCH	40 m <sup>3</sup> /h	40 m <sup>3</sup> /h	63 m <sup>3</sup> /h	63 m <sup>3</sup> /h
presiune de aspirare	0,5 mbar	0,5 mbar	0,5 mbar	0,5 mbar
putere/alimentare	1100 W/ 230 V	1100 W/ 230 V	1500 W/ 230 V	1500 W/ 230 V
greutate	145 kg	145 kg	159 kg	159 kg
lei	38549,00	38549,00	40399,00	40399,00

**MASINILE DE AMBALAT IN VID SENSOR ULTRA SU-800 CU PORT PENTRU IMPRIMANTA SI BLUETOOTH**

cod	1140884	1140890	1140896	1140938	1140948	1140958
model	SU-806P	SU-806P CC	SU-806P LL	SU-810P	SU-810P CC	SU-810P LL
dimensiuni exterioare	960x757x(H)998 mm	960x757x(H)998 mm	960x757x(H)998 mm	960x757x(H)998 mm	960x757x(H)998 mm	960x757x(H)998 mm
dimensiuni camera	864x603x(H)215 mm	864x603x(H)215 mm	864x603x(H)215 mm	864x603x(H)215 mm	864x603x(H)215 mm	864x603x(H)215 mm
lungime banda	530x848 mm	581+581 mm	848+848 mm	530+848 mm	581+581 mm	848+848 mm
capacitate pompa BUSCH	63 m <sup>3</sup> /h	63 m <sup>3</sup> /h	63 m <sup>3</sup> /h	100 m <sup>3</sup> /h	100 m <sup>3</sup> /h	100 m <sup>3</sup> /h
presiune de aspirare	0,5 mbar	0,5 mbar	0,5 mbar	0,5 mbar	0,5 mbar	0,5 mbar
putere/alimentare	1500 W/ 230 V	1500 W/ 230 V	1500 W/ 230 V	2200 W/ 230 V	2200 W/ 230 V	2200 W/ 230 V
greutate	232 kg	232 kg	232 kg	250 kg	250 kg	250 kg
lei	52649,00	49099,00	49499,00	57249,00	57249,00	57649,00

**MASINILE DE AMBALAT IN VID SENSOR ULTRA SU-6100 CU PORT PENTRU IMPRIMANTA SI BLUETOOTH**

cod	1141033	1141053
model	SU-6100P	SU-6160P
dimensiuni exterioare	1640x874x(H)1370 mm	1640x874x(H)1370 mm
dimensiuni camera	2x 662x656x(H)205 mm	2x 662x656x(H)205 mm
lungime banda	2x 662+662 mm	2x 662+662 mm
capacitate pompa BUSCH	100 m <sup>3</sup> /h	155 m <sup>3</sup> /h
presiune de aspirare	0,5 mbar	0,5 mbar
putere/alimentare	2200 W/ 230 V	4000 W/ 400 V
greutate	360 kg	360 kg
lei	85899,00	103599,00



1141033

**PLACA PENTRU AMBALAREA LICHIDELOR**

- Este livrat cu suport reglabil pentru punji disponibil pentru seriile 300/600/800



cod		lei
2141798	Sensor Ultra seria 800	517,99
2149074	Sensor Ultra seria 600	485,99
2149531	Sensor Ultra seria 300	453,99

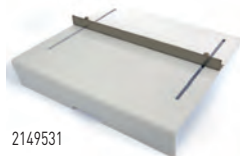

2149531



## MASINA DE GATIT PE GAZ KITCHEN LINE CU 4 ARZATOARE SI CUPTOR CU CONVECTIE GN 1/1



- Arzatoare: 2 x 3,5 kW + 2 x 6 kW
- Potrivit pentru oale cu diametrul cuprins intre  $\varnothing$ 120-300 mm
- Suport pentru tigaietie fonta 335x300 mm, unul pentru fiecare arzator
- Termocuplu
- Suprafata de gatit: AISI 304
- Corp: AISI 430
- Picioare din otel reglabile

### CUPTOR CONVECTIE GN 1/1:

- Electric 3 kW / 230 V
- Camera din otel inoxidabil: 640x370x(H)350 mm
- 4 perechi de sine pentru GN 1/1
- Distanta dintre sine: 75 mm
- 1 grila GN 1/1 inclusa
- Termostat

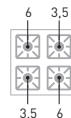
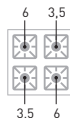
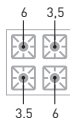

cod	227381	227589	225882
dimensiuni	800x700x(H)310 mm	800x700x(H)900 mm	800x700x(H)900 mm
dimensiuni cuptor	-	-	640x370x(H)350 mm
putere arzator	2x 3,5 kW + 2x 6 kW	2x 3,5 kW + 2x 6 kW	2x 3,5 kW + 2x 6 kW
tip cuptor	-	-	convectie electrica
putere cuptor	-	-	3 kW
putere totala	19 kW [HS]	19 kW [HS]	19 kW [HS]
alimentare	-	-	230 V
greutate	35 kg	82 kg	82 kg
lei	5119,00	6589,00	8789,00

## MASINA DE GATIT PE GAZ KITCHEN LINE CU 6 ARZATOARE SI CUPTOR CU CONVECTIE GN 1/1



- Arzatoare: 3 x 3,5 kW + 3 x 6 kW
- Potrivit pentru oale cu diametrul cuprins intre: Ø120-300 mm
- Suport pentru tigaie fonta 335x300 mm, unul pentru fiecare arzator
- Termocuplu
- Suprafata de gatit: AISI 304
- Corp: AISI 430
- Picioare din otel reglabile

- ### CUPTOR CONVECTIE GN 1/1:
- Electric 3 kW / 230 V
  - Camera din otel inoxidabil: 640x370x(H)350 mm
  - 4 perechi de sine pentru GN 1/1
  - Distanta dintre sine: 75 mm
  - 1 grila GN 1/1 inclusa
  - Termostat

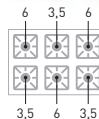
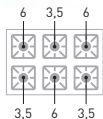

cod	226094	225899
dimensiuni	1200x700x(H)900 mm	1200x700x(H)900 mm
dimensiuni cuptor	-	640x370x(H)350 mm
putere arzator	3x3,5 kW + 3x6 kW	3x3,5 kW + 3x6 kW
tip cuptor	-	convectie electrica
putere cuptor	-	3 kW
putere totala	28,5 kW [HS]	28,5 kW [HS]
alimentare	-	230 V
greutate	95 kg	105 kg
lei	8049,00	10399,00



## MASINA DE GATIT ELECTRICA KITCHEN LINE CU 4 PLITE SI CUPTOR CU CONVECTIE GN 1/1



- Blat de lucru din otel inoxidabil AISI 304
- Panou lateral din otel inoxidabil AISI 430
- Dulap inchis pe 3 laturi, dimensiuni interioare:  
798x570x (H) 470 mm
- Incalzitoare din fonta: 4x ø220 mm, 2,6 kW fiecare
- Picioare reglabile, din otel 100-165 mm

- Electric 3 kW / 230 V
- Camera din otel inoxidabil: 640x370x(H)350 mm
- 4 perechi de sine pentru GN 1/1
- Distanța dintre sine: 75 mm
- 1 grila GN 1/1 inclusa
- Termostat

CUPTOR CONVECTIE GN 1/1:

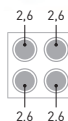
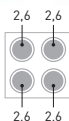

cod	226223	225936
dimensiuni	800x700x(H)900 mm	800x700x(H)900 mm
dimensiuni cuptor	-	635x370x(H)350 mm
putere arzator	4x 2,6 kW	4x 2,6 kW
tip cuptor	-	convectie electrica
putere cuptor	-	3 kW
putere totala	10,4 kW	13,4 kW
alimentare	400 V	400 V
greutate	65 kg	78 kg
lei	<b>4799,00</b>	<b>7459,00</b>

## MASINA DE GATIT ELECTRICA KITCHEN LINE CU 6 PLITE SI CUPTOR CU CONVECTIE GN 1/1

S.S.  
stainless steel

- Blat de lucru din otel inoxidabil AISI 304
- Panou lateral din otel inoxidabil AISI 430
- Dulap inchis pe 3 laturi, dimensiuni interioare: 1198x570x(H)470 mm
- Incalzitoare din fonta: 6x ø220 mm, 2,6 kW fiecare
- Picioare reglabile, din otel 100-165 mm

- Electric 3 kW / 230 V
- Camera din otel inoxidabil: 640x370x(H)350 mm
- 4 perechi de sine pentru GN 1/1
- Distanța dintre sine: 75 mm
- 1 grila GN 1/1 inclusa
- Termostat

### CUPTOR CONVECTIE GN 1/1:

blat: AISI 304,  
corp: AISI 430

cuptor electric  
GN 1/1

camera de otel  
otel inoxidabil

picioare din otel,  
ajustabile  
100-165 mm

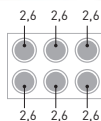
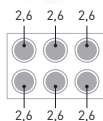

cod	226230	226247
dimensiuni	1200x700x(H)900 mm	1200x700x(H)900 mm
dimensiuni cuptor	-	635x370x(H)350 mm
putere arzator	6x 2,6 kW	6x 2,6 kW
tip cuptor	-	convectie electrica
putere cuptor	-	3 kW
putere totala	15,6 kW	18,6 kW
alimentare	400 V	400 V
greutate	90 kg	104 kg
lei	5949,00	9089,00





225707



225806

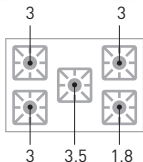

Vezi filmul

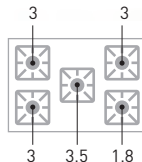

### MASINA DE GATIT 5 ARZATOARE SI CUPTOR ELECTRIC

- Potrivit pentru gaz metan.
- 3 arzatoare de 3,0 kW.
- 1 arzator de 1,8 kW.
- 1 arzator pentru wok de 3,5 kW.
- Aprindere piezo si termocuplu.
- Gratar fonta.
- Cuptor convectie GN 1/1 cu putere 2.7 kW, echipat cu 2 ventilatoare, termostat pana la 275°C si timer.
- Element suplimentar pentru grill de 2.5 kW.
- Usa interioara si interiorul cuptorului din otel inoxidabil.
- Greutate 78 kg.

cod	V	W	kW[HS]	mm	lei
225707	230	2900	14.3	900x653x(H)900	<b>7349,00</b>

### MASINA GATIT GAZ - 5 ARZATOARE, SUPORT DESCHIS

- Potrivit pentru gaz metan
- 3 arzatoare de 3,0 kW
- 1 arzator de 1.8 kW
- 1 arzator pentru wok de 3,5 kW
- Aprindere piezo si termocuplu
- Gratar fonta
- Greutate 45 kg

cod	kW[HS]	mm	lei
225806	14.3	900x640x(H)910	<b>5199,00</b>

839997



### ADAPTOR SUPORT VAS

- Pentru asezarea vaselor mici pe suporturile pentru vase mari



cod	mm	lei
839997	255x255x(H)25	<b>24,99</b>



237687

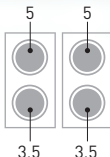

237670

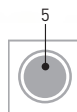

## MASINA DE GATIT CU INDUCTIE, CU 4 ARZATOARE

- Fabricat din otel inoxidabil durabil, ranforsat cu cadru.
- 2 plite de gatit cu inductie separate, de 320x560 mm fiecare, realizate din sticla calita cu grosimea de 5 mm.
- Echipat cu 2 arzatoare cu inductie de 5000 W si 2 arzatoare de 3500 W.
- Economii de energie de pana la 60% in comparatie cu masinile de gatit electrice standard.
- 4 butoane de comanda independente, dintre care puteti alege intre 11 niveluri de putere.
- Adecvat pentru oale si tigai cu inductie cu diametrul bazei de  $\varnothing 160 - 260$  mm.
- Incarcatura maxima permisa pentru plite: 100 kg.
- Picioare reglabile ( $\approx 30$  mm) pentru nivelarea perfecta a aragazului.
- Stativul ofera spatiu de depozitare suficient pentru oale, cratite sau alte accesorii.
- Filtru grasime usor de curatat.
- Stecherul nu este inclus.
- Atentie: unitatea trebuie conectata la sursa de alimentare de catre un electrician.

cod	V	W	mm	lei
237687	400	17000	800x720x(H)854	<b>9599,00</b>

## PLITA CU INDUCTIE DE MARE PUTERE

- Conceput pentru a fi utilizat cu wok-uri sau vase cu inductie foarte mari.
- Fabricat din otel inoxidabil durabil, ranforsat cu cadru.
- Suprafata de gatit cu inductie cu dimensiuni de 340 x 340 mm, realizata din sticla calita cu grosime de 5 mm.
- Plita cu inductie de 5.000 W.
- Economii de energie de pana la 60% in comparatie cu masinile de gatit electrice standard.
- Buton de control usor de utilizat, 11 niveluri de putere
- Operare sigura si confortabila datorita generarii de caldura numai la contactul dintre plita, oala sau cratita.
- Adecvat pentru oale si tigai cu inductie cu un diametru al bazei de  $\varnothing 160 - 300$  mm.
- Incarcatura maxima permisa pentru suprafata de gatit: 40 kg.
- Picioare reglabile ( $\approx 30$  mm) pentru amplasarea perfecta a aragazului.
- Stecherul nu este inclus.
- Atentie: unitatea trebuie conectata la sursa de alimentare de catre un electrician.

cod	V	W	mm	lei
237670	400	5000	422x400x(H)366	<b>2999,00</b>





6,7



147108



6



147801



10,8



147276

### ARZATOR PROFI LINE

- Pentru gaz propan si butan
- Cadru robust din otel inoxidabil pentru greutatea mari
- Echipat cu termocuplu si aprindere electronica
- Echipat cu suport vas emailat
- Furtun gaz si regulator de presiune incluse
- Poate fi completat cu suport aragaz (147306), inel wok (147207) si wok (626504)

### ARZATOR HENDI KITCHEN LINE

- Model Kitchen Line - pentru gaz propan si butan
- Set conversie pentru gaz metan inclus
- Cadru din otel inoxidabil
- Echipat cu termocuplu si aprindere electronica
- Echipat cu suport vas emailat
- Furtun gaz si regulator de presiune incluse

### ARZATOR HENDI KITCHEN LINE XL

- Model XL, pentru propan si gaz propan/butan.
- Set de convertizor inclus pentru a-l face potrivit si pentru gaze naturale.
- Prevezut cu un suport de tige emailat extra mare.
- Cadru complet din otel inoxidabil.
- Prevezut cu termocuplu si aprindere electronica.
- Furtun de gaz si regulator de presiune sunt incluse.

cod	kW[HS]	mm	lei
147108	6.7	425x425 x(H)400	2669,00

cod	kW[HS]	mm	lei
147801	6	400x440 x(H)390	1049,00

cod	kW[HS]	mm	lei
147276	10.8	580x650 x(H)400	1299,00

626504



147207

### WOK

- Din tabla de otel 1.5 mm grosime, cu manere
- Potrivit in special pentru suport wok din otel inoxidabil 149546 cu grill Green Fire cat si in combinatie cu inel din otel inoxidabil 147207 si aragaz 147108



cod	mm	lei
626504	ø710x(H)220	499,00

### INEL ARAGAZ

- Pentru adaptarea aragazului 147108 la folosirea wok-ului 626504



cod	mm	lei
147207	ø360x(H)80	337,99



220207

### FRYTOP PE GAZ, SUPRAFTA DE GATIRE NETEDA, CU SUPTOR INCHIS PE 3 LATURI

- Excelent pentru gatire fara grasimi
- Plita din otel moale S355J2, neteda
- Doua zone de incalzire, controlate separat, fiecare cu 3 tubular multiramp arzatoare din otel
- Puterea gazului unei zone de incalzire: 5 kW
- Temperatura controlata de un termocuplu cu supapa de siguranta care intrerupe alimentarea cu gaz a arzatoarelor in cazul in care flacara se stinge
- Aprindere electrica - este necesara conectarea la o sursa de alimentare de 230 V.
- Plita este usor inclinata spre fata pentru a face ca grasimea redusa sa curga in timpul gratarului, include o deschidere si un sertar glisat
- Baza realizata ca dulap deschis din otel AISI 430, inaltime de 380 mm
- Dispozitiv echipat standard cu duze de gaz NG50 (G30)
- Duze pentru cilindru GPL incluse
- Conexiune de gaz in partea din spate stanga, la aprox. 550 mm
- Picioare din otel reglabile de la 100 la 165 mm

cod	kW(HS)	mm	lei
220207	10	800x700x(H)900	11999,00

198124

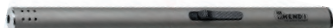

### BRICHETA - 2 BUCATI

- Reincarabila
- Bricheta se distribuie neincarcata

cod	ambalat pe	mm	lei
198124	2	(L)230	36,99

Pret catalog fara TVA

S.S.  
STAINLESS STEEL



238844

### FIERBATOR PASTE SI GALUSTE, DE BANC

- Pentru prepararea pastelor, galustelor si legumelor.
- Partea superioara a carcasei este fabricata din otel inoxidabil AISI 304.
- Alte parti ale carcasei (fara blatul de lucru) fabricate din otel inoxidabil AISI 430.
- Recipient realizat din otel inoxidabil AISI 316, cu o capacitate de 10 l.
- Elementul de incalzire se afla in partea inferioara a camerei, cu un capac.
- Conexiune directa la apa.
- Supapa pentru apa proaspata la panoul de comanda frontal.
- Reglare temperatura cu un cadran in interval: de la 30°C la 120°C.
- Indicator luminos care informeaza cu privire la atingerea temperaturii setate.
- Duza detasabila pentru apa uzata.
- Suport pentru cosuri destinate drenarii continutului.
- Blocare mecanica pentru prevenirea deschiderii accidentale a robinetului de golire.
- Protectie la supraincalzire cu resetare pe panoul de comanda frontal.
- Picioare anti-alunecare.
- Inclus: 2 cosuri de 100x292x(H)158 mm si un capac.
- Aparatul este livrat fara stecher.
- Aparat de sine statator - pe un suport.
- Stand inchis pe 3 laturi, fabricat din otel inoxidabil AISI 430.
- Dimensiunile interioare ale suportului: 325x545x(H)437 mm.
- Picioare reglabile in interval: 100-160 mm.

cod	V	W	mm	lei
238844	230	3500	330x600x(H)907	6049,00





273869

273876

273845

273883

273890

273852

### LAMPA CONICA PENTRU INCALZIRE

- Datorita cablului reglabil, aceasta lampa de caldura este foarte flexibila, lungimea cablului este reglabila de la 70 la 150 cm
- Cantitatea de caldura furnizata poate fi modificata prin ajustarea lungimii cablului
- Comutator pornit / oprit aflat pe partea de sus a lampii
- Becul propriu-zis este rezistent la spargere, facandu-l potrivit pentru mentinerea alimentelor calde



cod	mm	lei
273845	ø275x(H)250	<b>314,99</b>
273869	ø275x(H)250	<b>314,99</b>
273876	ø275x(H)250	<b>314,99</b>

### LAMPA CILINDRICA PENTRU INCALZIRE

- Datorita cablului reglabil, aceasta lampa de caldura este foarte flexibila, lungimea cablului este reglabila de la 70 la 150 cm
- Cantitatea de caldura furnizata poate fi modificata prin ajustarea lungimii cablului
- Comutator pornit / oprit aflat pe partea de sus a lampii
- Becul propriu-zis este rezistent la spargere, facandu-l potrivit pentru mentinerea alimentelor calde



cod	mm	lei
273883	ø175x(H)250	<b>269,99</b>
273890	ø175x(H)250	<b>269,99</b>
273852	ø175x(H)250	<b>269,99</b>



919217

### LAMPA INCALZIRE INFRAROSU

- Bec de inlocuire cu infrarosu pentru lampile de caldura
- Rezistent la soc, cu montare normala (E27)

cod	mm	lei
919217	ø125x(H)170	<b>62,99</b>



919200

### LAMPA INCALZIRE INFRAROSU

- Bec de inlocuire cu infrarosu pentru lampile de caldura
- Rezistent la soc, cu montare normala (E27)

cod	mm	lei
919200	ø125x(H)170	<b>58,99</b>



**NOU**

### LAMPA CU INCALZIRE FLEXIBILA

- Fabricat din metal.
- Lampa montata pe un brat flexibil.
- Bec cu infrarosiu rezistent la spargere inclus - adecvat pentru mentinerea la cald a alimentelor.
- Se potriveste cu becurile E27.

273838

cod	mm	lei
273838	268x200x(H)660	817,99

660 mm



Vezi filmul

### SUPORT CU 2 LAMPI INFRAROSU PENTRU INCALZIRE ALIMENTE

- Conceput pentru a mentine alimentele calde intre pregatire si servire.
- Inaltimea este usor reglabila intre 590 si 790 mm.
- Lampi de protectie incluse.



cod	mm	lei
273906	453x360x(H)790	529,99
273913	453x360x(H)790	549,99



273906

273913



## ROBOT DE BUCATARIE MULTIFUNCTIONAL HENDICHEF

ECHIPAMENTE BUCATARIE CALDA



# 20 de functii

gătire  
zdrobire  
amestecare  
framantare  
gătire la abur  
prăjire  
razuire  
sous vide  
aerare  
dizolvare  
caramelizare  
emulsifiere  
maruntire  
tocare  
macinare  
feliere  
sotare  
cantarire

- Un robot de bucatarie modern care permite:
  - gătirea automată cu ajutorul rețetelor preîncărcate
  - garantează pregătirea meselor gustoase și sănatoase într-un ritm rapid
  - gătirea manuală, adică setarea și modificarea parametrilor în mod continuu în timpul gătirii

#### Functii suplimentare:

- memorarea istoricului preparatelor pregătite
- cautati felurile de mancare preferate

#### Specificatii tehnice:

- Controlul temperaturii de la 37 °C la 130 °C
- Temporizator: 0-90 min
- Reglarea vitezei în 12 trepte a agitatorului
- Capacitate bol: 4,5 litri
- Putere de încălzire: 1000 W
- Puterea motorului: 1000 W
- Putere de amestecare: 1400 W
- Alimentare totală: 1400 W
- Greutate netă/brută: 17,2 kg/18,2 kg

cod	V	W	mm	lei
221761	230	1400	210x380x(H)320	<b>2179,00</b>
517123	Set: bol și accesorii pentru HENDI Chef			<b>549,99</b>

Set de gatit la abur din 3 piese,  
care include:

- Vas de gatire din polimer cu suprafata antiaderenta cu o capacitate de 4,5 l instalata pe recipientul pentru gatire - permite gatirea rapida cu abur
- Extinderea aburului marind zona de lucru de doua ori
- Capac care regleaza cantitatea de abur, astfel incat alimentele sa-si pastreze aromele complete



Capac transparent din policarbonat al oalei cu senzor de pornire, care va permite sa controlati procesul fara a deschide capacul



2 variante de capac: HOT COVER pentru prelucrarea la cald si COLD COVER pentru preparatele reci



Agitator pentru preparatele gatite



Cutite cu 4 lame realizate din otel rezistent la acid clasa AISI 420 intarit intr-un aspect 3D



Disc de taiere cu 2 functii - echipat cu 13 dinti, posibilitate de taiere



Spatula din silicon rezistenta la abraziune si temperatura



Pahar de masurare pentru dozare precisa



Recipient multifunctional de 4,5 litri (capacitate de lucru de 3 l) cu aparat de incalzire de mare putere instalat din otel inoxidabil anticoroziv de inalta calitate (tehnologia AISI 304)



Canar cuart integrata de la 5 g la 5 kg cu functie de tare

Carcasa motorului - din material antivibrat; Formula SLIDE LOCK previne schimbarea necontrolata a locului pe masa (material carcasa ABS)

Ecran TFT



## PLITE CU INDUCTIE KITCHEN LINE

- Design placut, potrivit pentru reprezentatie gatit
- Carcasa plata cu invelis negru si rama din otel inoxidabil
- Suprafata sticla ceramica cu display digital integrat

S.S.  
stainless steel

Vezi filmul



min Ø120 mm 2000 W  
max Ø220 mm 230 V

239391



min Ø140 mm 3500 W  
max Ø280 mm 230 V

239421

## PLITA CU INDUCTIE KITCHEN LINE 2000W

- Control touch, putere sau temperatura reglabile in 11 trepte.
- Interval de temperatura: 35-240°C.
- Potrivit pentru tigai cu diametrul bazei intre 120 si 220 mm.
- Cu functie de cronometru pentru 0-180 minute.
- Echipat cu protectie electronica impotriva supraincalzirii.
- Sarcina maxima a plitei cu inductie: 15 kg.

## PLITA INDUCTIE KITCHEN LINE 3500W

- Control touch, putere si temperatura reglabile in 10 trepte.
- Interval de temperatura: 35-240°C.
- Potrivita pentru vase cu diametrul inferior intre 140 mm si 280 mm.
- Cu functie timer pentru 0-180 minute.
- Echipata cu protectie electronica impotriva supraincalzirii.
- Sarcina maxima admisa a plitei cu inductie: 20 kg.

cod	V	W	mm	lei
239391	230	2000	297x411x(H)57	399,99

cod	V	W	mm	lei
239421	230	3500	339x444x(H)80	879,99



Structura din otel inoxidabil

Ventilatie eficienta

Panou touch



min Ø120 mm 3500 W  
max Ø220 mm 230 V

239414



Functioneaza si cu  
containere GN pana la 1/2

800 W  
230 V

239384

### PLITA DUBLA CU INDUCTIE KITCHEN LINE

- Control touch, putere si temperatura reglabile in 9 trepte
- Cu functie boost ce transfera o parte din putere de la o plita la alta, oferind pana la 2000 W
- Plita din stanga poate emite 1800 W sau 2000 W in timp ce functia boost este activa
- Plita din dreapta poate emite 1700 W
- Interval de temperatura: 35-240°C
- Potrivita pentru vase cu diametrul bazei intre 120 mm si 220 mm
- Cu timer 0-180 minute
- Echipata cu protectie electronica impotriva supraincalzirii
- Sarcina maxima admisa a plitei cu inductie: 2x15 kg

cod	V	W	mm	lei
239414	230	3500	608x405x(H)54	949,99

### PLITA INDUCTIE KITCHEN LINE

- Plita cu inductie unica, cu o bobina de inductie dreptunghiulara, ce permite sa fie incalzite mai multe tavi simultan
- Putere reglabila in 11 trepte, cu ajutorul unui buton
- Interval de temperatura: 40-100°C
- Echipata cu protectie electronica impotriva supraincalzirii



cod	V	W	mm	lei
239384	230	800	460x315x(H)61	616,99





Vezi filmul



Vezi filmul



 min  $\phi$ 140 mm 3500 W  
max  $\phi$ 280 mm 230 V

239711



 min  $\phi$ 160 mm 3500 W  
max  $\phi$ 300 mm 230 V

239698

**PLITA CU INDUCTIE MODEL 3500 D**

- Setare digitala a puterii, temperaturii si timpului prin touchscreen
- Carcasa din otel inoxidabil
- Filtru grasime usor de curatat si ventilare dubla
- Potrivita pentru vase cu diametrul inferior intru 140 mm si 280 mm.
- Picioare reglabile pe inaltime
- Sarcina maxima admisa a cuptorului: 20 kg

**PLITA CU INDUCTIE MODEL 3500 D XL**

- Setare digitala a puterii, temperaturii si timpului prin touchscreen
- Carcasa din otel inoxidabil
- Filtru grasime usor de curatat si ventilare dubla
- Potrivita pentru vase cu diametrul inferior intru 160 mm si 300 mm.
- Picioare reglabile pe inaltime
- Sarcina maxima admisa a plitei cu inductie: 20 kg

cod	V	W	mm	lei
239711	230	3500	342x431x(H)116	934,99

cod	V	W	mm	lei
239698	230	3500	390x560x(H)120	1089,00

**WOK INDUCTIE MODEL 3500**

- Carcasa din otel inoxidabil
- Filtru grasime usor de curatat
- Setare digitala a puterii
- Setarile au loc imediat
- A se folosi numai cu tige wok 239773
- Sarcina maxima admisa a plitei cu inductie: 20 kg



Vezi filmul



cod		V	W	mm	lei
239766	wok inductie	230	3500	340x450x(H)130	1149,00
239681	wok inductie + vas wok	230	3500	340x450x(H)295	1799,00



Vezi filmul



min ø140 mm 5000 W  
max ø280 mm 400 V

239322



min ø140 mm 5000 i 3500 W  
max ø280 mm 400 V

239346

### PLITA CU INDUCTIE MODEL 5000 D

- Setare digitala a puterii, temperaturii si a timpului, prin touchscreen
- Carcasa din otel inoxidabil
- Filtru grasime usor de curatat si ventilare dubla
- Potrivita pentru vase cu diametrul inferior intre 140 mm si 280 mm.
- Picioare reglabile pe inaltime
- Functioneaza cu 380V, se livreaza fara stecher, instalarea trebuie efectuata de electrician
- Sarcina maxima admisa a plitei cu inductie: 30 kg

cod	V	W	mm	lei
239322	400	5000	398x525x(H)175	1799,00

### PLITA INDUCTIE MODEL 7000

- Carcasa din otel inoxidabil cu 2 plite
- Plita din fata are o putere maxima de 5000 W, cand aceasta opereaza la 5000 W plita din spate poate genera doar 2000 W
- Plita din spate are o putere maxima de 3500 W doar cand plita din fata nu depaseste 3500 W
- Protectie electronica impotriva supraincalzirii
- Cu picioare metalice reglabile si filtru de aer detasabil
- Functioneaza cu 380V, se livreaza fara stecher, instalarea trebuie efectuata de electrician
- Potrivita pentru vase cu diametrul inferior intre 140 mm si 280 mm.
- Sarcina maxima admisa a plitei cu inductie: 20+20 kg

cod	V	W	mm	lei
239346	400	7000	405x700x(H)145	3499,00



Vezi filmul

min ø120 mm  
max ø260 mm  
3500 W  
230 V



239780



239773

### WOK

- Material 3 straturi.
- Cu maner din otel inoxidabil cu manson.
- Cu capac din otel inoxidabil.
- A se folosi cu 239766.

cod	mm	lei
239773	ø360x(H)180	374,99

### PLITA CU INDUCTIE MODEL 3500 M

- Putere ajustabila, fara trepte
- Carcasa din otel inoxidabil
- Sarcina maxima admisa a plitei cu inductie: 20 kg
- Potrivita pentru vase cu diametrul inferior intre 120 mm si 260 mm

cod	V	W	mm	lei
239780	230	3500	329x435x(H)106	849,99



min ø120 mm  
max ø260 mm  
1800 W  
230 V



239209

**PLITA CU INDUCTIE MODEL 1800**

- Carcasa din material plastic
- Setare digitala a puterii, temperaturii si timpului
- Setarile au loc imediat
- Sarcina maxima admisa a plitei cu inductie: 15 kg
- Potrivita pentru vase cu diametrul inferior intre 120 mm si 260 mm.

cod	V	W	mm	lei
239209	230	1800	319x355x(H)67	<b>289,99</b>

min ø120 mm  
max ø260 mm  
2000 W  
230 V



239230

**PLITA CU INDUCTIE MODEL 2000**

- Carcasa ingusta (32 mm) cu rama din otel inoxidabil
- Suprafata din sticla ceramica
- Control touch
- Sarcina maxima admisa pe plita: 15 kg
- Potrivita pentru vase cu diametrul inferior intre 120 mm si 260 mm.

cod	V	W	mm	lei
239230	230	2000	295x400x(H)42	<b>339,99</b>



239384

**PLITA INDUCTIE KITCHEN LINE**

- Plita cu inductie unica, cu o bobina de inductie dreptunghiulara, ce permite sa fie incalzite mai multe tavi simultan
- Putere reglabila in 11 trepte, cu ajutorul unui buton
- Interval de temperatura: 40-100°C
- Echipata cu protectie electronica impotriva supraincalzirii

cod	V	W	mm	lei
239384	230	800	460x315x(H)61	<b>616,99</b>



209509

**INCALZITOR TAVA**

- GN 1/1 - aluminiu.
- Pe baza izolata.
- Se incalzeste automat la 95 ° C.
- Poate fi folosit in combinatie cu Thermobox Kitchen Line GN 1/1 si mai mare (707906, 707968, 707951, 707944)

cod	V	W	mm	lei
209509	230	190	530x325x(H)45	<b>849,99</b>

**NOU**

**S.S.**  
stainless steel



250167



250174

### INCALZITOR SINGLE PENTRU FARFURII.

- Carcasa, rafturile si elementele de incalzire fabricate din otel inoxidabil.
- Pentru aprox. 72 farfurii cu dimensiuni intre ø24cm (40 farfurii - ø33 cm).\*
- Cu 3 rafturi detasabile, nereglabile pentru farfurii incluse: inaltime de 10 mm si latime de 340 mm.
- Distaanta dintre rafturi: 120 mm.
- Temperatura reglabila de la 30°C la 85°C.
- Protectie la supraincalzire declansata la 120°C.
- Usa cu garnitura magnetica.
- Comutator pornit/oprit cu indicatoare luminoase.
- Echipat cu 4 roti din care 2 au frane.
- Incalzitorul pentru farfurii dublu este disponibil si la HENDI - cod: 250174.
- \*Numarul de farfurii este general si poate varia in functie de dimensiunea, inaltimea si greutatea farfuriei utilizate.

cod	V	W	mm	lei
250167	230	400	393x571x(H)766	1639,00

### INCALZITOR DE FARFURII DUBLU

- Carcasa, rafturile si elementele de incalzire fabricate din otel inoxidabil.
- Pentru aprox. 108 farfurii cu dimensiuni intre ø24 cm (64 farfurii - ø33 cm).\*
- Cu 3 rafturi detasabile, nereglabile pentru farfurii incluse: inaltime de 10 mm si latime de 340 mm.
- Distaanta dintre rafturi: 120 mm.
- Temperatura reglabila de la 30°C la 85°C.
- Protectie la supraincalzire declansata la 120°C.
- Usa cu garnitura magnetica.
- Comutator pornit/oprit cu indicatoare luminoase.
- Echipat cu 4 roti din care 2 au frane.
- Este disponibila si versiunea single - cod: 250167.
- \*Numarul de farfurii este general si poate varia in functie de dimensiunea, inaltimea si greutatea farfuriei utilizate.

cod	V	W	mm	lei
250174	230	800	735x589x(H)766	2219,00





doua elemente de incalzire      luminaire sub raft



233962



### VITRINA CALDA CU DOUA NIVELE

- Carcasa din otel inoxidabil, cu sticla securizata, usile din sticla curbata si panoul din spate tip oglinda
- Cu doua nivele
- Acces prin fata datorita celor 2 usi curbate din sticla
- Rafturi cu capacitate de pana la 4 containere GN 1/2 (Containerele GN nu sunt incluse).
- Montat cu doua elemente de incalzire din cuart si o placa de incalzire electrica in partea de jos.
- Cu controler mecanic de temperatura.
- Montat cu iluminare in partea de sus.
- Interval de temperatura: 30 pana la 90 ° C

cod	V	W	mm	lei
233962	230	560	650x485x(H)630	2299,00



233726



233733



### VITRINA CALDA CU 3 NIVELE

- Prevazuta cu geam frontal dublu, curbat
- Trei nivele
- Acces cu usi glisante in spate
- Carcasa din otel inoxidabil
- Iluminare interioara cu LED, la partea superioara
- Cu 3 rafturi cromate, reglabile in inaltime
- Temperatura reglabila si display
- Interval de temperatura: 30°C/90°C
- dimensiuni rafturi interioare 93x63x74 cm

cod	-	V	W	mm	lei
233726	120 litri	230	1100	685x575x(H)680	2249,00
233733	160 litri	230	1500	885x570x(H)680	2699,00



Vezi filmul

Iluminat cu LED-uri

care gliseaza



## VITRINE CALDE DE BANC

- Carcasa din otel inoxidabil
- Panouri din sticla temperata
- Usi cu balamale localizate in spatele vitrinei - acces convenabil pentru curatare
- Tava pentru firmituri
- Temperatura ajustabila pana la 90°C



Vezi filmul



273982



273999

## VITRINA CALDA SINGLE

cod	V	W	mm	lei
273982	230	800	556x376x(H)315	1299,00

## VITRINA CALDA DUBLA

cod	V	W	mm	lei
273999	230	800	554x376x(H)376	1599,00

tava de scurgere

panou de comanda



## VITRINA CALDA

- Dotata cu usa in spate si partea frontala din sticla curbata.
- Caseta luminoasa cu camera pentru grafica promotionala.
- Carcasa din otel inoxidabil.
- Iluminare interioara.
- Cu 3 rafturi cromate, reglabile in inaltime 400x335 mm.
- Recipient de apa pentru umidificarea aerului in vitrina calda.
- Temperatura reglabila si display.
- Interval de temperatura: 30°C / 90°C



Vezi filmul



233740

cod	-	V	W	mm	lei
233740	97 litri	230	800	460x467x(H)785	2329,00





## VITRINA RECE CU DESCHIDERE FRONTALA SI DISPLAY

- Ideal pentru benzinarii, magazine mici, bucatarii de birou si cantine pentru a afisa orice mancare care nu necesita conditii speciale de depozitare.
- Capacitate camera 75 litri.
- Cu iluminare LED in partea de sus cu comutator pornit / oprit.
- Carcasa din otel inoxidabil prevazuta cu sticla securizata intarita.
- Echipat cu trei rafturi de sticla reglabile, usor inclinate spre client, 8 setari de raft disponibile la distanta de 45 mm.
- Baza din otel vopsit in negru cu acoperire din sticla: 390x325 mm.
- Raft din sticla de jos: 365x250 mm.
- Raft din sticla mijlocie: 365x230 mm.
- Raft de sticla superior: 360x195 mm.
- Partea superioara a vitrinei din otel vopsit in negru: 393x325 mm.
- Sticla laterala cu grosimea de 5 mm.
- Absenta geamului frontal face posibila autoservirea.
- Usa din sticla magnetica, cu articulatie dreapta, se deschide doar pe o parte.
- Adancitura practica de jos de 260x320x(H)85 mm pentru depozitarea marfurilor.
- Livrat cu 4 picioare din cauciuc, nereglabile: 15 mm inaltime.
- Cablu de alimentare: 1650 mm lungime cu mufa de 230 V impamantata.

cod	V	W	mm	lei
233092	230	2	415x390x(H)716	<b>1349,00</b>



Incarcare frontala si posterioara

S.S.  
stainless steel



233092

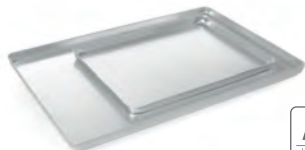

### TAVA PREZENTARE ARGINTIE

cod	mm	lei
808467	300x200x(H)20	<b>46,99</b>
808504	400x300x(H)20	<b>49,99</b>
808511	600x400x(H)20	<b>65,99</b>



### TAVA PREZENTARE AURIE

cod	mm	lei
808559	300x200x(H)20	<b>69,99</b>
808566	400x300x(H)20	<b>81,99</b>
808573	600x400x(H)20	<b>104,99</b>



407202

S.S.  
stainless steel

### TAVA PREZENTARE

- Cu picioare

cod	mm	lei
407202	240x170	<b>44,99</b>



407400

S.S.  
stainless steel

### TAVA PREZENTARE

- Nu este adecvata pentru temperaturi ridicate

cod	mm	lei
407400	345x245	<b>64,99</b>



## BAN MARIE HENDI RANGER

- Sistem de incalzire cu un covoras. Acest lucru asigura o economie de energie de 25% in comparatie cu solutiile traditionale, precum si o distributie uniforma a temperaturii.
- Carcasa si recipient de apa din otel inoxidabil.
- Se potriveste cu un recipient GN 1/1 cu inaltimea maxima de 150 mm.
- Adecvat si pentru combinatii de containere GN mai mici, precum 2x GN 1/2 sau 3x GN 1/3.
- Amplasarea recipientelor GN 1/6 este posibila cu conditia sa se utilizeze o bara adaptor (neinclusa in set, aceasta poate fi achizitionata separat - coduri: 808153, 808108).
- Interval de temperatura: de la 30°C la 85°C.
- Temperatura reglata cu un buton - 6 niveluri de incalzire.
- Prevazut cu un termostat si indicator luminos.
- Recipient de apa cu indicatoare de nivel min. si max. al apei.
- Protectie la supraincalzire.
- Clasificare impermeabilitate: IPX3.

**NOU**

**S.S.**  
stainless steel



Sistem de incalzire cu un covoras.  
Acest lucru asigura o economie de energie de 25% in comparatie cu solutiile traditionale, precum si o distributie uniforma a temperaturii.





238905

### BAIN MARIE HENDI RANGER

- Containerele GN nu sunt incluse in set.

cod	V	W	mm	lei
238905	230	1000	574x334x(H)241	514,99



238912

### BAIN MARIE HENDI RANGER CU ROBINET DE SCURGERE

- Containerele GN nu sunt incluse in set.

cod	V	W	mm	lei
238912	230	1000	576x334x(H)241	569,99



238967

### SET: BAIN-MARIE HENDI RANGER + 3X GN 1/3 CU CAPAC

- Inclus in set: 3 recipiente GN 1/3 cu inaltimea de 100 mm, cu capac.

cod	V	W	mm	lei
238967	230	1000	590x332x(H)242	642,99



238868

### SET RANGER: BAIN-MARIE CU ROBINET DE SCURGERE + 3X GN 1/3 CU CAPAC

- Inclus in set: 3 recipiente GN 1/3 cu inaltimea de 100 mm, cu capac.

cod	V	W	mm	lei
238868	230	1000	604x332x(H)242	665,99

### ADAPTOR IMBINARE VASCHETE

- Pentru montarea vaschetelor Gastronorm in bain-marie, in chafing dish-uri, etc

cod	GN	mm	lei
808108	GN 1/2	325x22x(H)10	15,99
808153	GN 1/1	530x22x(H)10	24,99



808153

808108





229064

### DESHIDRATOR ALIMENTE

- Pentru deshidratarea fructelor, legumelor, ierburilor, pestelui, etc.
- Aerul cald este pus in circulatie de ventilatoare automate pentru obtinerea unei deshidratari uniforme
- Echipat cu 7 tavi din otel inoxidabil 305x330 mm, capacitate de incarcare 500 gr fiecare
- Tavitele sunt distantate uniform si sunt usor de indepartat si curatat.
- Carcasa este realizata din polipropilena si cu pereti dubli, cu o temperatura mai buna.
- Datorita usii transparente, puteti urmari procesul de uscare.
- Livrat cu un suport transparent care poate fi folosit pentru colectarea rezidului pe fundul uscatorului sau pentru a face piele de fructe.
- Afisaj digital, reglabil de la 35 ° la 70 ° C.
- Timerul poate fi setat de la 30 de minute pana la 24 de ore in intervale de 30 de minute.

cod	V	W	mm	lei
229064	230	500	347x505x(H)320	<b>629,99</b>



Comenzi usoare



Usor de deschis



Cu plasa fina pentru uscarea articolelor mici

## DESHIDRATOR ALIMENTE PROFI LINE 6 TAVI

- Carcasa din otel inoxidabil
- Panou de control digital
- Timer reglabil pana la 24 de ore cu trepte de 30 de minute
- Temperatura reglabila de la 35°C la 75°C cu trepte de 5°C
- Ventilatoarele silentioase circula aerul cald pentru un rezultat uniform la uscare, fara a fi necesara rotirea tavilor
- Echipat cu 6 tavi din otel inoxidabil, 305x330 mm
- Tavile sunt distantate uniform si sunt usor de indepartat si curatat
- Datorita usii transparente, puteti observa procesul de uscare

cod	-	V	W	mm	lei
229033	6 tavi	230	650	342x485x(H)309	<b>779,99</b>



6 tavi  
600 W  
230 V



229033

## DESHIDRATOR ALIMENTE PROFI LINE 10 TAVI

- Carcasa din otel inoxidabil
- Pentru uscarea fructelor, legumelor, ierburilor, carnii, pestelui, etc.
- Panou de control digital
- Timer reglabil pana la 24 de ore cu trepte de 30 de minute
- Temperatura reglabila de la 35°C la 75°C cu trepte de 5°C
- Ventilatoarele silentioase circula aerul cald pentru un rezultat uniform la uscare, fara a fi necesara rotirea tavilor
- Echipat cu 10 tavi din otel inoxidabil, 395x380 mm
- Tavile sunt distantate uniform si sunt usor de indepartat si curatat
- Datorita usii transparente, puteti observa procesul de uscare

cod	-	V	W	mm	lei
229026	10 tavi	230	1000	430x550x(H)416	<b>1279,00</b>

10 tavi  
1000 W  
230 V



229026



Vezi filmul



Camera de uscare cu spatiu pentru 10 tavi



Panou de comanda digital usor de utilizat



Tampon cu reziduuuri inclus



Gratar pliabil  
pentru gogoasa



205914



Un sistem „zona rece”  
care separa reziduurile  
de frigere de sub nivelul  
incalzitului

Robinet  
de scurgere

### FRITEUZA ADANCA PENTRU GOGOSI 12 L

- Ideal pentru prajit gogosi, angel wings, beignets, gogosi olandeze si alte produse de patiserie din aluat.
- In intregime din otel inoxidabil, vine cu doua grilaje de prajire (354x383mm) cu maner rece la atingere, cu protectie de incalzire si un capac care poate servi si ca tava pentru picurare.
- Usor de utilizat si curat, potrivit pentru utilizare intensa si cantitati mari.
- Montat cu un rezervor mare de ulei sudat (400x400x (H)160 mm) cu o presiune maxima, capacitate de 12 litri.
- Rezervorul echipat cu robinet de scurgere si marcajul nivelului uleiului min / max, are o zona rece pentru imbunatatirea duratei de utilizare a uleiurilor.
- Element de caldura detasabil cu functie de oprire la demontare si protectie la supraincalzire.
- Temperatura poate fi setata de la 50 °C pana la 190 °C.
- Lampa indicatoare de incalzire pentru a arata daca elementul de incalzire functioneaza.
- Cu picioare anti-alunecare din cauciu.

cod	litri	V	W	mm	lei
205914	12	230	3500	630x860x(H)438	1599,00



## FRITEUZE PROFI LINE

- Friteuzele din gama „Profi Line” sunt fabricate din oțel inoxidabil 18/0
- Element detasabil cu funcție oprire când este îndepărtat
- Container ulei în formă de V pentru îmbunătățirea zonei reci
- Butoanele de control cu lampile de avertizare ale temperaturii se găsesc pe partea superioară a echipamentului
- Un termostat asigură protecție împotriva supraîncălzirii, poate fi repornit prin intermediul butonului de resetare aflat sub element
- Cosul de prajire cu maner lung transformă acest model într-un echipament deosebit pentru utilizare intensivă
- Toate friteuzele se livrează cu cos(urile) și capac(e)

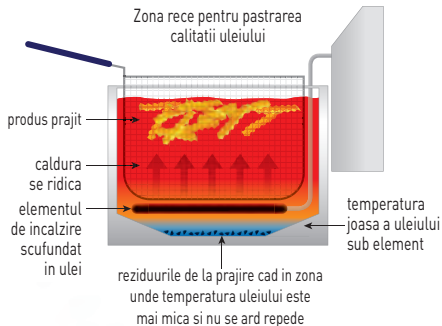

XL  
10  
litri



### FRITEUZA PROFI LINE CU ROBINET DE SCURGERE - 10L, 400 V

- Friteuza foarte puternică de 400 V, permite elementului de încălzire să utilizeze până la 6600 W putere.
- Reduce timpul de recuperare a temperaturii după introducerea alimentelor congelate, rezultând alimente mai crocante.
- Se livrează fără stecher, instalarea se face de o persoană avizată.

cod	litri	V	W	mm	lei
209424	10	400	6600	300x680x(H)420	1599,00



## FRITEUZA PROFI LINE DIGITALA

- Gama Profi Line de friteuze este fabricata din otel inoxidabil 18/0.
- Element cu functie de oprire cand este scos.
- Rezervorul de ulei cu baza in forma de V asigura o zona frigorifica optima, care creste durata de utilizare a uleiului.
- Panou de control digital clar, cu functie de temperatura si temporizator.
- Protejat impotriva supraincalzirii cu ajutorul unei sigurante termice re-setabile.
- Un cos de prajit cu maner extrem de lung transforma acest model intr-o piesa fina de echipament pentru utilizare intensiva.
- Toate friteuzele de adancime vin cu cos (uri) de prajire si capac (e).

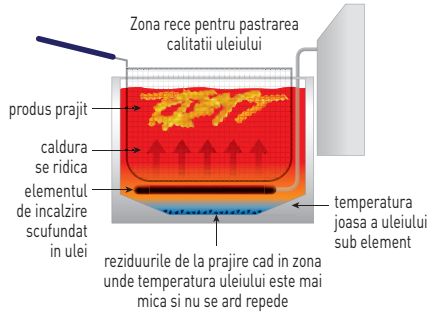

Vezi filmul



8 litri  
3500 W  
230 V



207369

### FRITEUZA PROFI LINE CU ROBINET SCURGERE - 8 LT

- Panou de control digital clar, cu functie de temperatura si temporizator.

cod	litri	V	W	mm	lei
207369	8	230	3500	305x515x(H)345	1199,00



2x 8 litri  
2x 3500 W  
230 V



207376

### FRITEUZA PROFI LINE CU ROBINET SCURGERE - 2 X 8 LT

- Panou de control digital clar, cu functie de temperatura si temporizator.

cod	litri	V	W	mm	lei
207376	16	230	7000	605x515x(H)350	2099,00

## FRITEUZE PROFI LINE

- Friteuzele din gama „Profi Line” sunt fabricate din oțel inoxidabil 18/0
- Element detasabil cu funcție oprire când este îndepărtat
- Container ulei în forma de V pentru îmbunătățire zona rece
- Butoanele de control cu lampile de avertizare ale temperaturii se găsesc pe partea superioară a echipamentului
- Un termostat asigură protecție împotriva supraîncălzirii, poate fi repornit prin intermediul butonului de resetare aflat sub element
- Cosul de prajire cu maner lung transformă acest model într-un echipament deosebit pentru utilizare intensivă
- Toate friteuzele se livrează cu cos(uri) și capac(e)

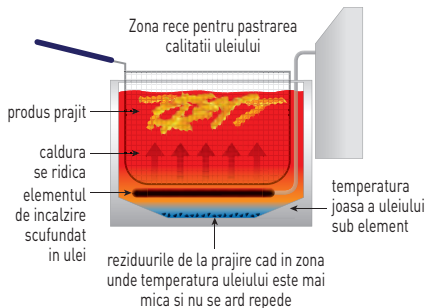

8 litri  
3500 W  
230 V

207208



2x 8 litri  
2x 3500 W  
230 V



207307

### FRITEUZA PROFI LINE - 8 LT

cod	litri	V	W	mm	lei
207208	8	230	3500	305x460x(H)369	804,99

### FRITEUZA PROFI LINE - 2 X 8 LT

cod	litri	V	W	mm	lei
207307	16	230	7000	605x460x(H)369	1599,00



8 litri  
3500 W  
230 V

209202

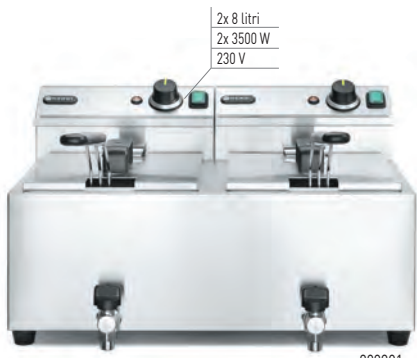

2x 8 litri  
2x 3500 W  
230 V

209301

### FRITEUZA PROFI LINE CU ROBINET SCURGERE - 8 LT

cod	litri	V	W	mm	lei
209202	8	230	3500	305x515x(H)354	949,99

### FRITEUZA PROFI LINE CU ROBINET SCURGERE - 2 X 8 LT

cod	litri	V	W	mm	lei
209301	16	230	7000	610x515x(H)369	1699,00





205815



205839

### FRITEUZA KITCHEN LINE

- Carcasa din otel inoxidabil
- Vas ulei din otel inoxidabil
- Elementul detasabil cu sistem inchidere cand este scos
- Vasul de ulei detasabil face curatarea mai usoara
- Lampa de avertizare functionare a elementului de incalzire
- Temperatura poate fi reglata pana la 190 °C
- Un termostat de siguranta pentru evitarea supraincalzirii
- Protectie la supraincalzire, cu resetare
- Un cos de prajire cu maner lung, izolat
- Zona rece, care imbunatateste calitatea uleiului
- Include cos si capac

cod	litri	V	W	mm	lei
205808	4	230	3000	217x380x(H)300	<b>479,99</b>
205846	4+4	230	3000+3000*	470x420x(H)330	<b>829,99</b>
205815	6	230	3300	265x430x(H)290	<b>509,99</b>
205853	6+6	230	3300+3300*	550x430x(H)290	<b>939,99</b>
205822	8	230	3500	265x430x(H)345	<b>559,99</b>
205839	8+8	230	3500+3500*	550x430x(H)345	<b>1049,00</b>



Vezi filmul

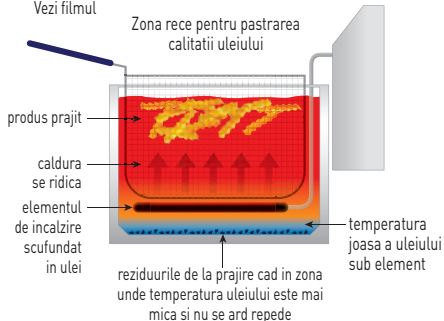

Zona rece pentru a proteja calitatea uleiului



Recipient de ulei detasabil, care faciliteaza curatarea



Cos de prajire cu izolatie termica si maner foarte lung



8 litri  
3500 W  
230 V



215012

2x 8 litri  
2x 3500 W  
230 V



215029

### FRITEUZA CU INDUCTIE CU ROBINET SCURGERE

- Control precis al temperaturii, cu o tehnologie ce mentine uleiul exact la temperatura setata
- Cu cronometru
- Transfer eficient al caldurii
- Carcasa din otel inoxidabil pentru o curatare usoara
- Protectie la supraincalzire
- Display cu temperatura setata
- Include cos si capac



Vezi filmul

### FRITEUZA CU INDUCTIE CU ROBINET SCURGERE - 8 LT

cod	litri	V	W	mm	lei
215012	8	230	3500	288x619x(H)408	1449,00

### FRITEUZA CU INDUCTIE CU ROBINET SCURGERE - 2 X 8 LT

cod	litri	V	W	mm	lei
215029	16	230	7000	577x609x(H)410	3159,00

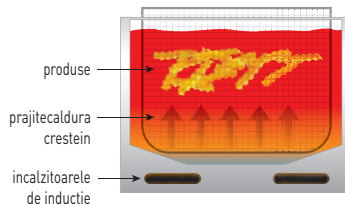

Robinetul de scurgere  
faciliteaza golirea friteuzei



Cu filtru pentru  
motorul cu inductie

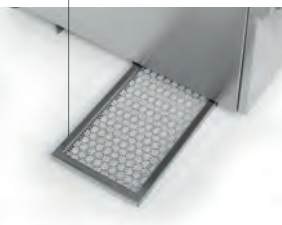

Margine convenabila  
pentru cosul suspendat



18/0

Standard steel

**FRYTOP PROFESIONAL PROFI LINE**

- Carcasa din otel inoxidabil
- Plita de fier dura (9 mm), cromata, usor de curatat
- Dotat cu o tava detasabila de scurgere a grasimii si panouri inalte impotriva stropirii
- Termostat ajustabil pana la 300°C
- Protectie supraincalzire
- Potrivit pentru uz continuu
- Buton functionare cu lampa indicatoare integrata
- Picioare anti-alunecare



Vezi filmul



203125

**GRATAR**

- Suprafata gratar 330x270 mm, neteda

cod	-	V	W	mm	lei
203125	neted	230	2000	300x452x(H)227	<b>1099,00</b>



203156

**GRATAR PE JUMATATE STRIAT**

- Suprafata gratar 518 x 328 mm, stanga 259 mm neteda si dreapta 259 mm striata

cod	-	V	W	mm	lei
203156	1/2 neted, 1/2 striat	230	2400	550x435x(H)245	<b>1359,00</b>



203170

**GRATAR STRIAT**

- Suprafata gratar 518 x 328 mm, striata

cod	-	V	W	mm	lei
203170	striat	230	2400	550x435x(H)245	<b>1699,00</b>



203149

**GRATAR**

- Suprafata gratar 518 x 328 mm, neteda in intregime

cod	-	V	W	mm	lei
203149	neted	230	2400	550x455x(H)244	<b>1199,00</b>



203163

**GRATAR CU STRIATII 1/3**

- 2 zone independente de lucru, 2 lampi avertizare incalzire
- Suprafata gratar 688 x 410 mm, stanga 462 mm neteda si dreapta 226 mm striata

cod	-	V	W	mm	lei
203163	2/3 neted, 1/3 striat	230	3500	720x550x(H)245	<b>1859,00</b>



855201

855218

**RACLETA GRATAR**

cod	mm	lei
855201	100x320	<b>59,99</b>

**LAME DE REZERVA PENTRU 855201**

cod	lei
855218	<b>20,59</b>

## GRATARE KITCHEN LINE.

- Carcasa fabricata din oțel inoxidabil.
- Placa solida din oțel calit, cu grosimea de 8 mm, ofera o retinere excelenta a caldurii.
- Prevazut cu protectie anti stropire.
- Temperatura reglabila fara trepte pana la 300°C.
- Protectie la supraincalzire cu ajutorul unui intrerupator termic resetabil.
- Comutator de alimentare cu lampa de indicare integrata.
- Montat cu picioare anti-alunecare.

S.S.  
stainless steel

**NOU**



154922

### GRATAR

- Gratarul masoara 316x380 mm si este complet neted.

cod	-	V	W	mm	lei
203125	neted	230	2000	300x452x(H)227	<b>1249,00</b>



154939

### GRATAR

- Gratarul masoara 518x330 mm si este complet neted.

cod	-	V	W	mm	lei
203125	neted	230	2000	300x452x(H)227	<b>1099,00</b>



154946

### GRATAR PE JUMATATE STRIAT

- Gratarul masoara 518x330 mm si este pe jumătate striat.

cod	-	V	W	mm	lei
203156	1/2 neted, 1/2 striat	230	2400	550x435x(H)245	<b>1359,00</b>



154953

### GRATAR STRIAT

- Gratarul masoara 518x330 mm si este complet striat.

cod	-	V	W	mm	lei
203170	striat	230	2400	550x435x(H)245	<b>1699,00</b>



154960

### GRATAR CU STRIATII 1/3

- Gratarul masoara 688x410 mm si este 1/3 striat si 2/3 neted.  
- Dispune de doua zone de incalzire reglabile separat si o zona fara elemente de incalzire care utilizeaza caldura reziduala.

cod	-	V	W	mm	lei
203163	2/3 neted, 1/3 striat	230	3500	720x550x(H)245	<b>1859,00</b>

**CONTACT GRILL**

- Perfect pentru gatirea la gratar si incalzirea painii, bucatilor de carne, carnatilor, legumelor etc. Grillul din fonta este usor de curatat si intretinut.
- Carcasa fabricata din otel inoxidabil 18/10 garanteaza durabilitate.
- Elementele de incalzire de mare putere incalzesc rapid gratarele.
- Temperatura poate fi setata continuu, utilizand termostatul, de la 0 °C la 300 °C. Deschiderile de ventilare protejeaza gratarul impotriva supraincalzirii.
- Gratar inferior prevazut cu margini posterioare si laterale si

- o tava de scurgere detasabila, care simplifica curatarea.
- Ridicati gratarul superior cu manerul rezistent la caldura si blocati-l in orice pozitie gratie mecanismului cu inchidere prin resort.
- Prevazut cu intrerupator de retea cu indicator luminos integrat, indicator luminos de preincalzire si cablu de alimentare de 1,7 m cu stecher cu impamantare.
- Cu picioarele din cauciu, reducand deplasarea accidentala in timpul utilizarii.
- Peria pentru curatarea gratarului este inclusa in kit.



Vezi filmul

**CONTACT GRILL - VERSIUNE SIMPLA**

- Suprafata grill 220 x 230 mm
- Striata

cod	V	W	mm	lei
263501	230	1800	310x426x(H)510	<b>764,99</b>

**CONTACT GRILL - VERSIUNE SIMPLA**

- Suprafata grill 220 x 230 mm
- 1/2 striata si 1/2 neteda

cod	V	W	mm	lei
263600	230	1800	310x400x(H)510	<b>679,99</b>

1800 W  
230 V



### CONTACT GRILL „PANINI”

- Suprafata grill 340 x 230 mm
- Striata

cod	V	W	mm	lei
263655	230	2200	432x396x(H)214	939,99



### CONTACT GRILL PANINI

- Suprafata grill 340 x 230 mm
- 1/2 striata si 1/2 neteda

cod	V	W	mm	lei
263662	230	2200	430x370x(H)514	874,99

2200 W  
230 V



**XL**  
→ | 545 mm | ←

3000 W  
230 V



### GRATAR DE CONTACT „PANINI” XL

cod	V	W	mm	lei
263624	230	2700	548x464x(H)231	1369,00



### CONTACT GRILL - VERSIUNE DUBLA STRIATA

- Termostate reglabile independent
- Suprafata grill inferioara 475 x 230 mm
- Striata

cod	V	W	mm	lei
263709	230	3600	570x395x(H)510	1299,00



### CONTACT GRILL - VERSIUNE DUBLA

- Termostate reglabile independent
- Suprafata grill inferioara 475 x 230 mm
- 1/2 striata si 1/2 neteda

cod	V	W	mm	lei
263808	230	3600	570x395x(H)510	1199,00



### CONTACT GRILL - VERSIUNE DUBLA

- Termostate reglabile independent
- Suprafata grill inferioara 475 x 230 mm
- 1/2 neted, 1/2 striat

cod	V	W	mm	lei
263907	230	3600	575x430x(H)510	1289,00

3600 W  
230 V





#### Versatil si eficient

Structura groasa din otel inoxidabil, panou si maner din poliamida (SmartVide 9 realizat in intregime din otel inoxidabil)

#### Extrem de usor de utilizat

##### Panou de control simplu si intuitiv

Display de 3,5", rezistent la apa, usor de utilizat

4 butoane si afisaj color TFT

3 moduri de cronometru:

- operare continua
- functionare cu temporizator
- functionare cu sonda de temperatura

#### Sistem de control al temperaturii

##### de precizie, masoara temperatura

cu o toleranta de pana la 0,01 °C

Precizie de top importanta pentru gatirea produselor delicate cum ar fi pestele, legumele sau fructele

#### Aparatele sous-vide SmartVide sunt

echipate cu un circulator care pune apa in miscare, astfel incat se poate mentine o temperatura constanta chiar si in recipiente mari



**Conexiune Bluetooth pentru confort maxim** – Control HACCP eficient al procesului de gatire – exporta sau imprima parametrii de gatit dupa fiecare ciclu

**Salveaza propriile programe de gatit** si verifica starea dispozitivului – temperatura si timpul de lucru ramas

**Actualizarea datelor din fabrica** furnizate de producator

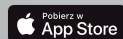

## CIRCULATOR SOUS VIDE 5, 7, 9

 **sammic**

- Datorita unei structuri solide si a unei carcase din otel inoxidabil cu grosime mare, este utilizata in aplicatii profesionale gastronomice
- Panou de comanda si maner din poliamida armata
- fibra de sticla (modele SmartVide 5 si 7) sau otel inoxidabil (SmartVide 9)
- Sistemul precis de control al temperaturii va permite sa obtineti rezultate repetabile, mentinand in acelasi timp calitatea produsului, imbunatatind, de asemenea, gustul si textura acestuia
- Va permite sa gatiti alimentele intr-o pungă vidata fara contact direct al alimentelor cu apa, ceea ce are un efect pozitiv asupra intensificarii aromei, eliminand pierderea in greutate si va permite sa utilizati decoctul produs in punga pentru a prepara sosuri
- Va permite sa aromatizati ulei, grasimi sau altele asemenea
- produse folosind tehnica temperaturii controlate
- Datorita unui panou de control simplu si intuitiv, dispozitivul
- Necesita un timp scurt de supraveghere directa, permitand bucatarului sa indeplineasca alte sarcini in timp ce gateste produsul

- Ecran TFT rezistent la apa, color, de 3,5", care arata parametrii de gatit: timpul, temperatura reala si temperatura setata
- Interval de temperatura: 5 - 95 ° C
- Precizie temperatura: 0,01 ° C
- Temporizator: de la 1 min la 99 de ore, gradatie de 1 min
- Conexiune Bluetooth
- Sonda optionala
- Unitatile de temperatura ° C si ° F pot fi modificate
- Este posibila calibrarea dispozitivului
- Repornire automata
- Indicator de nivel minim al apei pe carcasa
- Moduri de lucru cu Timer - lucru continuu cu un temporizator, cu un timp stabilit - toate acestea pentru a eficientiza munca dvs. si mai mult
- Posibilitatea de a salva programele de gatit prin Bluetooth
- Setul vine cu o geanta eleganta, ergonomica, care permite transport sigur si convenabil al dispozitivului cu dvs. (numai model SmartVide 9)
- Capacitatea maxima pentru 1180100 este 30l sau GN 1/1 (H) 200 mm, pentru 1180120 este 56l sau GN 2/1 (H) 200 mm, pentru 1180140 este 56l sau GN 2/1 (H) 200 mm



1180100



1180120



1180140



cod	model	V	kW	capacitate maxima container	mm	kg	lei
1180100	SmartVide 5	230	1,6	30 l lub GN 1/1 (H) 200 mm	116x128x(H)330	3,1	<b>3989,00</b>
1180120	SmartVide 7	230	2	56 l lub GN 2/1 (H) 200 mm	124x140x(H)360	3,6	<b>5049,00</b>
1180140	SmartVide 9	230	2	56 l lub GN 2/1 (H) 200 mm	124x140x(H)360	4,2	<b>6299,00</b>





**Durabilitate si performanta.**  
Ecran tactil color de 5".  
Construcție din oțel inoxidabil.

**Extrem de simplu de utilizat.**  
**Panou de comanda simplu si intuitiv.**  
Ecran tactil color de 5".  
Comutati usor intre °C si °F.

**Optimizarea si confortul muncii dvs.**  
Capacitatea de a conecta SmartWide X  
la un recipient incalzit reduce timpul  
de incalzire.  
Aceasta functie este utila mai ales  
atunci cand gatiti sau reincalziti  
alimente foarte reci sau congelate.



## SISTEM DE GATIT SOUS-VIDE PRIN CIRCULAREA APEI MODEL SMARTVIDE X

**sammic**

- Circuloarele Samic SmartVide sunt dispozitive inovatoare pentru prepararea alimentelor sous vide
- Datorita structurii solide din otel inoxidabil acestea au o utilizare perfecta in gastronomia profesionala
- Sistemul precis de control al temperaturii permite obtinerea rezultatelor, pastrand in acelasi timp aroma, valoarea nutritiva si calitatea adecvata a texturii produsului
- O metoda speciala de gatire a alimentelor in pungi vidate fara contactul alimentelor gatite cu apa, are un efect benefic sporind aroma si reduce pierderea de masa
- Posibilitate de aromatizare a uleiului, grasimilor sau a altor produse folosind tehnica sous vide
- Panou de control usor de utilizat, meniu intuitiv
- Afisaj color TFT rezistent la apa care arata parametrii gatire: timp, temperatura reala si temperatura setata

- Interval de temperatura: 5 ° - 95 °C
- Precizie de citire: 0,01 °C
- Timer: 1 min-99 h, gradatie: 1 min
- Conexiune Bluetooth
- Sonda optionala
- Posibilitatea de a schimba selectia unitatilor de temperatura: °C sau °F
- Abilitatea de a calibra dispozitivul
- Pornire automata
- Indicator de nivel minim al apei pentru protejarea circuloarelor impotriva daunelor
- Moduri de functionare cu temporizator - functionare continua cu contor timp - pentru o mai buna organizare a muncii
- Posibilitatea de a salva programe de gatit prin Bluetooth
- Structura din otel, panou de comanda si maner otel inoxidabil
- Potrivit pentru cuve cu o capacitate maxima de 56 l
- Motor puternic de 2000 W
- Greutate neta: 4,4 kg
- Geanta pentru transportul in siguranta al dispozitivului inclusa (1180085)
- Recipient izolat GN 2/1 (H) de 200 mm pentru circulatorul SmartVide X vandut separat (1.180.075)
- Marker Janby Track Mini pentru marcare pungilor si monitorizarea procesului de gatire inclus



1180160



cod	model	V	kW	capacitate maxima container	mm	kg	lei
1180160	SmartVide X	230	2	56 l sau GN 2/1	125x148x(H)385	4,4	<b>8989,00</b>

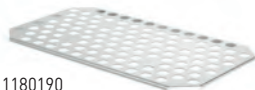

1180190

### BAZA DE DISTANTARE PENTRU RECIPIENTE PENTRU REZERVOARE IZOLATE

- Fabricat din otel inoxidabil.
- Model 1180190 pentru containere GN 1/1 (1180060).
- Model 1180191 pentru containere GN 2/1 (1180065).

cod	GN	lei
1180190	GN 1/1	<b>259,99</b>
1180191	GN 2/1	<b>414,99</b>



1180070

### RECIPIENT IZOLAT GN 1/1 SI 2/1 PENTRU CIRCULOARE SMARTVIDE

- Container inovator cu propriul sistem de incalzire, pentru atingerea mai rapida a temperaturii dorite
- Ideal pentru gatit foarte rece sau produse congelate
- Fabricat din otel inoxidabil
- Robinet de scurgere inclus

cod	litri	V	W	GN	lei
1180070	28	230	800	GN 1/1	<b>4949,00</b>
1180075	56	230	1600	GN 2/1	<b>6719,00</b>



1180060

### RECIPIENT IZOLAT GN 1/1 SI 2/1 PENTRU CIRCULATOR SMARTVIDE

- Carcasa din otel inoxidabil
- Economii de energie datorate izolarii termice a containerului
- Echipat cu un robinet de scurgere
- Adancimea cuvei de apa 150 mm
- Comandati separat capacul recipientului

cod	litri	mm	lei
1180060	28	335x600x(H)288	1929,00

### GEANTA KIT SOUS VIDE PENTRU MODELE SMARTVIDE 5,7, 9 SI X

- Perfect in special pentru bucatarii care merg in deplasari.

cod	lei
1180085	339,99



### BILE DIN POLIPROPILENA PENTRU CIRCULATOR SMARTVIDE 1000 DE PIESE

- Utilizat pentru a reduce evaporarea si stropirea cu apa in timpul gatitului
- Formeaza un strat izolator in recipiente deschise, reducand pierderile de caldura
- Ajuta la pastrarea pungii vidate cu produsul gatit sub apa
- Diametrul unei singure bile este de 20 mm
- Poate fi utilizat la temperaturi de pana la 110 °C si in majoritatea lichidelor de gatit Sous Vide

cod	lei
1180080	499,99



1180062

### CAPACE GN 1/1 SI 2/1 PENTRU RECIPIENTELE POMPEI DE CIRCULATIE SMARTVIDE

- Fabricat din otel inoxidabil.
- Previne evaporarea in timpul procesului de gatire.
- Se potriveste cu recipientele standard din otel inoxidabil GN 1/1 si 2/1 si cu recipientul Sammic izolat, special pentru pompa de circulatie SmartVide.
- Cu maner.

cod	mm	lei
1180062	GN 1/1 - SmartVide 5	269,99
1180063	GN 2/1 - SmartVide 4 si 6	302,99
1180067	GN 2/1 - SmartVide 6, 7, 8 si 9	488,99



1180085



1180090

### SONDA AC PENTRU SMARTVIDE 5, 7, 9, X

- Controlati temperatura produsului gatit pe parcursul ciclului
- Masurare: de la 5 °C la 95 °C
- Distanța sondei 80 mm

cod	mm	lei
1180090	(L)80	961,99

### GARNITURA DE SPUMA PENTRU SONDA ACULUI

- Utilizat pentru a evita pierderea vidului din pungă atunci când se utilizează sonda acului
- Dimensiuni: 4000x10 mm

cod	mm	lei
5170060	4000x10	194,99



5170060

## SISTEM DE GATIT SOUS-VIDE

- Sistem culinar in care produsul alimentar sigilat in vid este gatit la o temperatura controlata cu precizie
- Ideal pentru restaurante „a la carte”
- In mod exceptional potrivit pentru pregatirea in afara orelor de varf
- Rezultatele sunt in mod constant de inalta calitate

- Termostat de inalta precizie (0,1°C) reglabil de la 35° la 90°C
- Carcasa realizata in intregime din otel inoxidabil
- Poate fi sigilat ermetic, capacul este prevazut cu banda din silicon



GN 1/1  
600 W  
230 V



225448

GN 2/3  
400 W  
230 V



225264

## SISTEM DE GATIT SOUS VIDE GN 1/1

- Echipat cu manere si robinet scurgere
- Distantier din otel inoxidabil, cu 6 compartimente, inclus

cod	litri	V	W	mm	lei
225448	20	230	600	350x680x(H)275	1429,00

## SISTEM DE GATIT SOUS VIDE GN 2/3

- Echipat cu manere.
- Distantier din otel inoxidabil cu 4 compartimente incluse.

cod	litri	V	W	mm	lei
225264	13	230	400	343x395x(H)255	1039,00



## PUNGI VACUUM PENTRU GATIT - 100 BUCATI

cod	ambalat pe	mm	lei
971369	100	150x200	24,99
971345	100	150x250	34,99
971376	100	200x300	48,99
971352	100	250x350	69,99
971383	100	300x400	83,99



971376





### Versatil si eficient

Structura groasa din otel inoxidabil,  
panou si maner din poliamida

### Sistem de control al temperaturii de precizie, masoara temperatura cu o toleranta de pana la 0,01 °C

Precizie de top importanta pentru  
gatirea produselor delicate cum  
ar fi pestele, legumele sau fructele

### Extrem de usor de utilizat

#### Panou de control simplu si intuitiv

Display de 3,5", rezistent la apa, usor  
de utilizat

4 butoane si afisaj color TFT

3 moduri de cronometru:

- operare continua
- functionare cu temporizator
- functionare cu sonda de temperatura

Aparatele sous-vide SmartVide sunt  
echipate cu un circulator care pune  
apa in miscare, astfel incat se poate  
mentine o temperatura constanta  
chiar si in recipiente mari

## SISTEM DE GATIT SOUS-VIDE PRIN CIRCULARA APEI HENDI MASTERVIDE



**NOU**



PENTRU VASE  
CU O CAPACITATE  
MAXIMA DE  
**56 l**

222546



- Permite gatirea alimentelor fara contact direct cu apa - in pungi vidate speciale, care absorb aroma alimentelor, reduc pierderea in greutate si permit utilizarea stocului produs in punga pentru prepararea sosurilor.
- Posibilitate de aromatizare a uleiului, grasimii sau a altor produse folosind metoda in vid.
- Constructie durabila fabricata din otel inoxidabil.
- Carcasa si manerul panoului de comanda sunt realizate din poliamida durabila ranforsata cu fibra de sticla.
- Panou de comanda simplu si usor de utilizat.

- Adekvat pentru containere cu capacitate maxima de 56 l, inaltime de 150 mm si perete cu o grosime de pana la 30 mm.
- Sistem precis de control al temperaturii pentru a obtine rezultate repetabile - interval de temperatura 5°C - 95°C, cu o precizie de setare de pana la 0,1°C.
- Unitate de afisare a temperaturii interschimbabile: °C sau °F.
- Motor puternic de 2000 W.
- Temporizator: de la 1 min la 99h, cu interval de 1 min.
- 3 moduri de lucru: functionare continua, functionare continua cu temporizator.

cod	litri	V	W	mm	lei
222546	56	230	2000	137x215x(H)361	<b>4799,00</b>



**sousvide**  
tools.com



Wi-Fi



222645

### STICK IVIDE 2.0

- Pentru siguranta, stick-ul Sous Vide se opreste cand este scos din baia de apa
- Control WiFi posibil, aplicatie disponibila pentru dispozitive iOS si Android
- Aplicatia ajuta utilizatorii sa calculeze timpul perfect si temperatura, preincarcata cu peste 600 de retete
- Temperatura poate fi setata intre 5°C si 90°C cu trepte de 0,1°C
- Poate incalzi si circula pana la 30 de lt de apa
- Poate circula 12 lt de apa pe minut
- Ecranul luminos afiseaza temperatura si timpul de lucru, usor de operat
- Intregul corp este rezistent la apa IPX7 (submersiune)

cod	V	W	mm	lei
222645	230	1200	65x120x(H)340	<b>744,99</b>

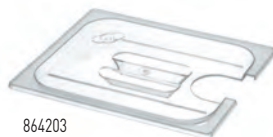

864203



### CAPAC GASTRONORM

- Fara fanta
- Potrivite si pentru vaschete Profi Line din otel inoxidabil

cod	GN	mm	lei
864210	GN 1/2	265x325	<b>69,99</b>
864203	GN 1/1	530x325	<b>94,99</b>



222638



Wi-Fi

### IVIDE PLUS JUNIOR

- Circulator termic de inalta precizie cu control cu temperatura.
- Interfata cu ecran tactil de inalta rezolutie de 4 inch.
- Proiectat pentru a se potrivi oricarui vas rotund sau plat de gatit cu o adancime minima de 16,5 cm, prin intermediul unei cleme.
- Cele mai bune performante se obtin cu maxim 45 de litri de apa.
- Temperatura de lucru de la 5 ° C pana la 99 ° C, precizie 0,07 ° C.
- Temporizatorul poate fi setat intre 1 minut si 99 de ore.
- WiFi activat, poate fi controlat de aplicatia sousvidetools.
- Mai multe ustensile pot fi gestionate din aplicatie.
- Protectia impotriva nivelului scazut al apei opreste sous vide-ul, in caz de utilizare accidentala fara apa.
- Pompa de circulatie elimina punctele reci si fierbinti.
- IPX7, poate rezista la stropiri si scufundari accidentale.

cod	V	W	mm	lei
222638	230	1500	165x119x(H)285	<b>1779,00</b>



Wi-Fi



222997



### IVIDE PLUS SOUS VIDE TERMIC

- Pompa termica de inalta precizie sous vide cu control al temperaturii.
- Interfața cu ecran tactil de 4 inch.
- Conceput pentru a se potrivi cu orice vas rotund sau plat cu o adancime minima de 16,5 cm cu ajutorul unei cleme.
- Cele mai bune performante pana la 80 de litri.
- Temperatura de lucru de la 5°C la 99°C, cu o precizie de 0.07°C.
- Timerul poate fi setat intre 1 minut si 99 de ore.
- Mai multe masini pot fi gestionate din App.
- Oferă o stabilitate exceptionala a temperaturii.
- Dispozitivul de protectie opreste aparatul in caz de utilizare accidentala fara apa.
- Pompa de circulatie pentru a elimina zonele reci si calde.
- Senzor de temperatura pentru a preveni supraincarea.
- IPX7, poate rezista stropilor si submersiunii accidentale.

#### Aplicatie:

- Faciliteaza controlul precis al temperaturii de oriunde.
- O colectie de peste 600 de retete.
- Sous Vide Calculator: Am facut toate testele si cercetarile pentru dvs., ceea ce inseamna ca nu mai parcurgeti internetul pentru informatii.
- Reteta Memorie: pastrati-va propriile intervale de timp si temperaturi.
- Istorical procesului de gatire: pentru un control mai bun HACCP, pastreaza ultimele 10 retete si temperaturi.
- Gatire cu mai multe dispozitive: Control mai multor masini de gatit formeaza o aplicatie.
- Notificari pentru confirmarea momentului cand apa este la temperatura dorita si mancarea este gatita. Cand timpul de gatire este complet, nu va faceti griji, aplicatia va pastra alimentele la temperatura optima pentru a le mentine.

cod	V	W	mm	lei
222997	230	2200	140x190x(H)276	2859,00



### CAPAC CU ORIFICIU PENTRU SOUS VIDE STICK

- Cu orificiu pentru Sous Vide stick 222997.
- Potrivit si pentru containerele gastronom Profi Line

cod	GN	mm	lei
864234	GN 1/2	265x325	69,99
864227	GN 1/1	530x325	89,99

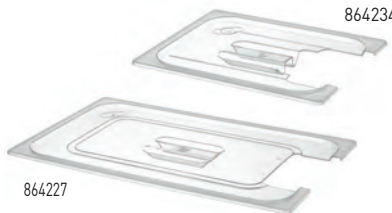

864234

864227





Vezi filmul



240410

### FIERBATOR DE OREZ CU FUNCTIE DE GATIT PE ABURI PROFI LINE

- Carcasa este fabricata din otel inoxidabil.
- Vas interior detasabil realizat din aluminiu cu strat antiaderent, usor de curatat.
- Capacul din polipropilena cu balama este prevazut cu o garnitura convenabil, o garnitura etansa si o supapa de ventilare.
- Capacul este inchis etans datorita incuietorii integrate.
- Cu ajutorul colectorului integrat de condens impiedica udarea bancului de lucru.
- Doua moduri de functionare - gatire si pastrarea la cald; dupa gatire, aparatul intra in modul de mentinere la cald.
- Poate fi folosit si pentru a gati legume la abur, utilizand cosul inclus.
- Capacitate: 10 linguri de orez uscat (15-20 de portii de orez gatit).
- Inclus: cos pentru steamer, ceasca si lingura de masurat orez si lingura.

cod	litri	V	W	mm	lei
240410	1.8	230	700	ø280x(H)285	219,99



240403

### FIERBATOR SI INCALZITOR OREZ PROFI LINE

- Carcasa fabricata din otel inoxidabil.
- Vas interior detasabil realizat din aluminiu cu strat antiaderent, usor de curatat.
- Capacul din otel inoxidabil cu balama este prevazut cu o garnitura etansa la aer si o supapa de aerisire.
- Capacul este inchis etans datorita incuietorii integrate.
- Cu ajutorul colectorului integrat de condens impiedica udarea bancului de lucru.
- Doua moduri de functionare - gatire si pastrare la cald; dupa gatire, aparatul intra in modul de mentinere la cald.
- Capacitate: 30 de linguri de orez uscat (45-60 de portii de orez gatit).
- Inclusa: cos pentru steamer, ceasca si lingura pentru masurarea orezului.

cod	litri	V	W	mm	lei
240403	5.4	230	1950	513x422x(H)775	849,99



240441

**APARAT PENTRU FIERT OREZ 4.2 LITRI**

- Carcasa este confectionata din otel vopsit alb, usor de curatat.
- Vas interior realizat din aluminiu, cu strat anti-aderent, usor de curatat.
- Dispozitivul de blocare cu rasucire, capac din otel inoxidabil, este prevazut cu un maner care ramane rece.
- Manerele au un design special care le permite sa actioneze ca suport pentru capac, sa depoziteze in siguranta capacul fierbinte si sa tina intotdeauna capacul la indemana.
- Manerele si picioarele sunt confectionate din polipropilena durabila, care nu se incalzesc.
- Doua moduri de functionare - gatire si pastrarea la cald; dupa gatire, aparatul intra in modul de mentinere la cald.
- Capacitate: 23 de linguri de orez uscat (=46 de portii de orez gatit).
- Include: ceasca si lingura pentru masurarea orezului.
- Greutate neta: 4,8 kg.

cod	litri	V	W	mm	lei
240441	4.2	230	1550	391x372x(H)315	<b>399,99</b>



240458

**APARAT PENTRU FIERT OREZ 10 LITRI**

- Carcasa este fabricata din otel vopsit alb, usor de curatat.
- Vas interior realizat din aluminiu, cu strat anti-aderent, usor de curatat.
- Dispozitivul de blocare cu rasucire, capac din otel inoxidabil, este prevazut cu un maner care ramane rece.
- Manerele au un design special care le permite sa actioneze ca suport pentru capac, sa depoziteze in siguranta capacul fierbinte si sa tina intotdeauna capacul la indemana.
- Manerele si picioarele sunt confectionate din polipropilena durabila, care nu se incalzesc.
- Doua moduri de functionare - gatire si pastrarea la cald; dupa gatire, aparatul intra in modul de mentinere la cald.
- Capacitate: 50 de linguri de orez uscat (=100 de portii de orez gatit).
- Include: ceasca si lingura pentru masurarea orezului.
- Greutate neta: 10,35 kg.

cod	litri	V	W	mm	lei
240458	10	230	2900	528x487x(H)370	<b>565,99</b>



2000 W  
230 V



Vezi filmul



264119

## SALAMANDRA MONTABILA PE PERETE

- In conformitate cu normele IPX4
- Poate fi instalata pe perete fara a necesita alte sisteme de prindere
- Ideala pentru incalzire sandwich-uri sau alte feluri de mancare
- Temperatura reglabila de la 50°C pana la 300°C
- Cu element incalzire la partea superioara
- Echipata cu termostat, timer 30 min. si lampa avertizare
- 4 inaltimi disponibile pentru gratar, manere protejate impotriva incalzirii
- Tava firimituri

cod	V	W	mm	lei
264119	230	2000	610x450x(H)275	<b>949,99</b>



2850 W  
230 V

**NOU**



264126

## SALAMANDRA GN 1/1

- Fabricat din otel inoxidabil.
- Posibilitatea de a amplasa o tava GN 1/1 in camera (nu este inclusa in set).
- Elementul de incalzire din partea superioara a camerei.
- Posibilitatea de a amplasa grila pe 4 niveluri diferite de inaltime.
- Montabil pe perete, fara suporturi suplimentare, pentru a economisi spatiu in bucatarie.
- Prevazut cu un termostat, un temporizator de pana la 30 de minute si un indicator luminos.
- Reglare lina, fara trepte - asigura setarea precisa a parametrilor de incalzire.
- Interval de temperatura: 50-300°C.
- Clasificare de protectie la infiltrare: IPX4 - protectie impotriva stropirii cu apa.
- Accesorii incluse in set:
  - grila cu 2 manere izolate,
  - tava pentru firimituri.

cod	V	W	mm	lei
264126	230	2850	770x485x(H)305	<b>1499,00</b>



3600 W  
230 V



264300

## SALAMANDRA

- Ideal pentru caserole, gratare si incalzirea farfuriilor.
- Controlul temperaturii: 50°-300°C.
- Cu element de incalzire superior.
- Prevazut cu termostat, cronometru de 30 min. si led indicator.
- 4 posibile inaltimi ale grilei.
- Furnizat cu: grila cu manere si tava pentru firimituri.
- Dimensiuni interne: 646x408x(H)337 mm.
- Fabricat din otel inoxidabil.

cod	V	W	mm	lei
264300	230	3600	800x633x(H)453	<b>1599,00</b>



3645 W  
230 V



INCALZIRE  
IN 10s

### SALAMANDRA CU QUARTZ, ELEMENTE DE INCALZIRE CU INFRAROSU

- Este posibila amplasarea tavilor GN1 / 1 in camera
- Ideal pentru gratare sau incalzirea felurilor de mancare sau a sandwich-urilor
- Cu element de incalzire cu infrarosu pe partea superioara si inferioara
- Montat cu 15 min. cronometrul si indicatorul luminos

S.S.  
STAINLESS STEEL

- 3 inaltimi posibile ale gratarului, manerele grilajului prevazute cu scut termic
- Cu tava pentru firimituri
- Conform normei IPX3

cod	V	W	mm	lei
264409	230	3645	765x490x(H)315	1699,00

### SALAMANDRA CUART MAXI GN 1/1

- Salamandra cuart MAXI GN 1/1
- Salamandra grill cu 9 arzatoare cuart pentru incalzire rapida, prajire si gratinare
- Protectie din otel a arzatoarelor, impotriva deteriorarii
- Carcasa din otel inoxidabil
- 2 gratare placate cu crom cu dimensiunile 530x340 mm si 2 manere detasabile
- 2 nivele pentru fiecare gratar - distante de 70 mm si 45 mm
- Tava firimituri din otel inoxidabil
- Arzatoare cuart - 3 arzatoare pe 3 nivele independente
- Timer arzatoare - se poate seta pana la 15 min sau operare continua
- Cablu de alimentare 1,3 m, fara stecher

cod	V	W	mm	lei
264331	400	4500	682x528x(H)455	2709,00

S.S.  
STAINLESS STEEL

4500 W  
400 V

INCALZIRE  
IN 10s



264331



Cu 9 incalzitoare cu cuart pentru incalzire, frigere si gratinare mai rapide



### SALAMANDRA 450

- Tip 450 - cadru din otel inoxidabil
- Ideal pentru frigere sau incalzire feluri de mancare sau sandwich-uri
- Termostat pentru reglarea temperaturii pana la 300 °C, cu lumini de avertizare
- Inaltime reglabila prin intermediul sistemului de ridicare
- Tava colectare firimituri detasabila, cu gratar 440x320 mm

cod	V	W	mm	lei
264607	230	2800	485x525x(H)537	1899,00

### SALAMANDRA 600

- Tip 600 - cadru din otel inoxidabil
- Ideal pentru frigere sau incalzire feluri de mancare sau sandwich-uri
- Termostat pentru reglarea temperaturii pana la 300 °C, cu lumini de avertizare
- 2 zone independente de incalzire
- Inaltime reglabila prin intermediul sistemului de ridicare.
- Tava colectare firimituri, detasabila, cu gratar 590x350 mm

cod	V	W	mm	lei
264706	230	3600	619x500x(H)525	2189,00



**NOU**



### PRAJITOR CU 4 FELII

- Carcasa fabricata din otel inoxidabil, satinata si lucioasa.
- Butoane de selectare din ABS, butoane si pedale din PP (polipropilena).
- 4 fante de prajire foarte late, 2 zone de incalzire (cate 2 fante fiecare), 2 tavi detasabile pentru firimituri.
- Maneta de ridicare pentru a scoate painea prajita fara efort.
- Capacitate pentru 4 felii de paine simultan.
- 7 niveluri de prajire ajustate cu butoane - fiecare zona de incalzire poate fi configurata diferit.
- 3 programe presetate: paine prajita, decongelare, reincalzire.
- 3 butoane functionale pentru fiecare zona de incalzire: dezghetare, reincalzire, evacuare/anulare.

cod	V	W	mm	lei
261187	240	1500	295x335x(H)180	299,99



Vezi filmul

262214



### TOASTER CU 6 COMPARTIMENTE

- 2 niveluri cu 6 cleme de prajire - oțel inoxidabil
- Tuburi cu cuarț infraroșu pentru încălzire rapidă, temperatura poate atinge maximum în 30 de secunde. Tuburile se răcesc în câteva secunde
- 2 niveluri cu reglaj independent al temperaturii
- Cronometru mecanic de 15 minute cu avertizor
- 6 cleme de prajire incluse

cod	V	W	mm	lei
262214	230	3000	450x390x(H)400	849,99



262801

### GRATAR PENTRU TOASTER

cod	mm	lei
262801	100x340x(H)64	25,49



### SANDWICH TOASTER

- Carcasa din oțel inoxidabil
- Gratare echipate cu manere izolate termic
- Gratarele se pot opera separat
- Timer cu alarma reglabila la maxim 8 minute
- Tava firimituri detasabila

cod	V	W	mm	lei
261163	230	1200	215x300x(H)270	699,99



261163





Vezi filmul

**TOASTER TIP TUNEL**

- Bandade prajire pentru felile de paine.
- 2 elemente separate de incalzire, unul deasupra si unul sub tunel.
- Potrivit pentru prajirea continua a painii feliate.
- Echipat cu 2 tavi, fata si spate.
- Viteza benzii este reglabila, timpul de prajire este cuprins intre 0:45 si 3:15 de minute.

cod	V	W	mm	lei
261200	230	1340	288x368x(H)410	1799,00

**TOASTER TIP TUNEL DUBLU**

- Posibilitatea de a praji paine pe 2 randuri
- 2 elemente de incalzire separate
- Conceput pentru prajirea continua a feliiilor de paine
- 2 tavi de dozare: fata si spate
- Reglarea timpului de prajire pana la 3 minute



cod	culoare	V	W	mm	lei
261309		230	2240	418x365x(H)390	1899,00
261354	Negru	230	2240	418x368x(H)415	2199,00

**S.S.**  
STARTERS STORE



Vezi filmul

## CUPTOR PIZZA

- Tava gratar potrivita pentru pizza cu diametrul de pana la 30 cm
- Timer reglabil pana la 15 min
- Cu elemente incalzire in partea de sus si la baza si cu tava firimituri
- Potrivit pentru pizza inghetata

cod	V	W	mm	lei
220306	230	1450	484x590x(H)190	<b>619,99</b>



220306

## TIGAIE PARTY

- Aluminiu cu strat anti-aderent
- Termostat detasabil
- Potrivita pentru prajirea si pastrarea calda a mancarii
- Echipata cu capac transparent si 2 manere incorporate

cod	V	W	mm	lei
239605	230	1600	ø620x(H)170	<b>353,99</b>
239506	230	1400	ø400x(H)190	<b>199,99</b>

**Al**  
aluminum



239605

239506



Pret catalog fara TVA

**HENDI**

323



**GRILL ROLA PENTRU CARNATI**

- Carcasa din otel inoxidabil
- Incalzire rapida si pastrarea caldurii
- Role cu strat anti-aderent
- Tava picurare detasabila, usor de curatat
- Rolele au o latime utila de 42 cm
- Temperatura reglabila pana la 150°C



Vezi filmul



7 role  
740 W  
230 V

268506

cod	-	V	W	mm	lei
268605	9 role	230	940	520x425x(H)175	<b>1149,00</b>
268506	7 role	230	740	525x365x(H)176	<b>999,99</b>



14 role  
1480 W  
230 V

268735

cod	-	V	W	mm	lei
268704	11 role	230	1180	530x525x(H)180	<b>1299,00</b>
268735	14 role	230	1480	520x650x(H)176	<b>1499,00</b>



268742

**PANOU DE STICLA PENTRU GRILL-URILE PENTRU CARNATI**

- Acest lucru permite utilizarea cu pana la 20% mai putina energie electrica.
- Acumularea de caldura sub capacul de sticla reduce timpul de gatire a carnatilor cu pana la 15%.
- Inaltimea maxima de deschidere este de 250 mm.
- Fabricat din trei elemente de sticla, fiecare de cate 4 mm grosime.
- Grinda din otel inoxidabil sustine elementele din sticla, cu 4 suporturi din plastic rezistent la caldura pentru montarea capacului gratarului.
- Atentie: capacul din sticla se potriveste numai cu noile gratare, cu gauri in rame.

cod	pentru grill-ul pentru carnati	mm	lei
268551	cu 7 role [268506]	470x325x(H)240	<b>229,99</b>
268612	cu 9 role [268605]	470x401x(H)250	<b>269,99</b>
268711	cu 11 role [268704]	470x477x(H)250	<b>299,99</b>
268742	cu 14 role [268735]	470x591x(H)250	<b>349,99</b>

## INCALZITOR CARNATI



Vezi filmul

10 litri  
1000 W  
230 V



240502

### INCALZITOR CARNATI 10 LT

- Termostat reglare temperatura pana la 85°C
- Cu manere pentru transport
- Capacul cu maner izolat

cod	V	W	mm	lei
240502	230	1000	405x290x(H)254	539,99



Vezi filmul



450 W  
230 V

265000

### INCALZITOR CRENVURSTI

- Incalzește crevurști și îi menține calzi
- Carcasa din oțel inoxidabil, container din aluminiu anodizat și sticlă
- Cu putere reglabilă

cod	V	W	mm	lei
265000	220-240	450	239x335x(H)470	949,99

## THERMOSYSTEM



Vezi filmul



201107

4,2 litri  
200 W  
230 V



201206

2x 4,2 litri  
400 W  
230 V

### THERMOSYSTEM

- 1 vas emailat Ø 185 mm
- Vas bain-marie din oțel inoxidabil, cu capac
- Echipat cu regulator de putere și lampa avertizare

cod	litri	V	W	mm	lei
201107	4.2	230	200	254x310x(H)312	844,99



### THERMOSYSTEM

- 2 vase emailate Ø 185 mm
- 2 vase bain-marie din oțel inoxidabil, cu capace
- Echipat cu 2 regulatoare de putere și lampi avertizare

cod	litri	V	W	mm	lei
201206	8.4	230	400	496x310x(H)312	1399,00





20 litri  
1050 W  
230 V

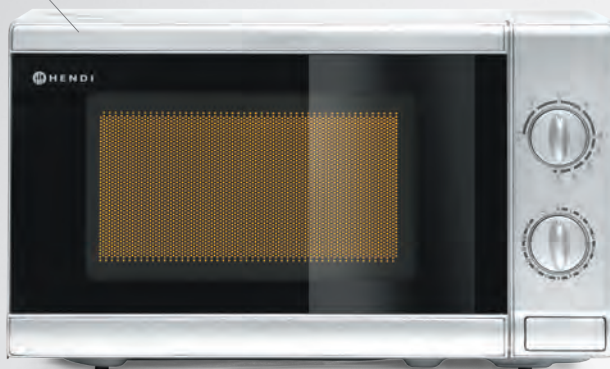

281710



Vezi filmul

## CUPTOR CU MICROUNDE CU GRILL HENDI 1050 W, 20 L

281710

- Carcasa din otel inoxidabil si panou frontal.
- Panou de comanda usor de citit.
- Comanda electromecanica cu doua butoane de reglare a duratei si puterii - 9 niveluri.
- Antena magnetronului superior cu arbore rotativ asigura distribuirea uniforma a energiei.
- Filtru de aer integrat pentru a proteja impotriva factorilor externi si a prafului.
- Usa etansa cu un panou de sticla pentru observarea proceselor din interiorul iluminat al cuptorului cu microunde.
- Deschidere prin buton pentru utilizare facila.
- Interior camera:
  - dimensiuni 304x306x(H)206, capacitate 20 L.
  - vopsit alb.
  - usor de curatat.
  - fara blocarea farfuriilor datorita marginilor rotunjite corespunzator.
- Utilizare multifunctionala:
  - decongelare.
  - 4 niveluri de putere microunde: Scazuta, Medie, Medie ridicata, Ridicata.
  - functia de combinare a modului standard si a modului gratar: Combina (3 niveluri).
  - gratar (putere 1000 W).
  - terminarea ciclului de gatire este semnalizata de o alarma acustica.
- Puterea microundelor: 1.050 W.
- Include un platou din sticla de ø255 mm si suportul gratarului.
- Adekvat pentru farfurii rotunde (pana la ø280 mm).
- Durata maxima de functionare: 35 de minute.
- Echipat cu un cablu cu un stecar cu impamantare.
- Greutate: 11,1 kg.



cod	litri	V	W	mm	lei
281710	20	230	1050	435x360x(H)251	529,99

25 litri  
 1550 W  
 230 V



281352

## CUPTOR CU MICROUNDE HENDI 1550 W, 23 L

**281352**

- Carcasa si interiorul camerei cu baza ceramica fabricat din otel inoxidabil.
- Panou de comanda usor de citit.
- Comanda electromecanica cu un buton de reglare a timpului de la 15 s la 6 min.
- Antena magnetron rotativa mai joasa pentru distribuirea uniforma a energiei, fara disc rotativ.
- Filtru de aer integrat pentru a proteja impotriva factorilor externi si a prafului.
- Usa cu geam mare pentru observarea proceselor din interiorul iluminat al cuptorului cu microunde.
- Inchidere transa a zavorului; deschidere simpla - fara mecanism de blocare.
- Interior camera:
  - dimensiuni 327x346x(H)200 mm, capacitate 23 l.
  - usor de curatat.
  - fara blocarea farfuriilor, gratie marginilor rotunjite corespunzator.
  - baza ceramica.
- Utilizare multifunctionala:
  - decongelare.
  - 6 programe de timp sugerate pentru prepararea anumitor preparate/bauturi.
  - sfarsitul ciclului de gatire este semnalat de o alarma acustica.
- Puterea microundelor: 1550 W.
- Potrivit pentru farfuriile rotunde (pana la  $\varnothing$ 320 mm) si dreptunghiulare.
- Durata maxima de functionare: 6 minute.
- Echipat cu un cablu cu steacar cu impamantare.
- Greutate: 15,1 kg.



cod	litri	V	W	mm	lei
281352	25	230	1550	582x472x(H)374	1449,00





25 litri  
1550 W  
230 V



281444



Vezi filmul

## CUPTOR CU MICROUNDE PROGRAMABIL HENDI 1000 W, 23 L

281444

- Carcasa si interiorul camerei cu baza ceramica fabricata din otel inoxidabil.
- Panou de comanda usor de citit.
- Comanda electronica.
- Antena magnetron rotativa inferioara pentru distribuirea uniforma a energiei, fara disc rotativ.
- Filtru de aer integrat pentru a proteja impotriva factorilor externi si a prafului.
- Puteti selecta programul dorit de pe panoul tactil.
  - usa cu geam mare pentru observarea proceselor din interiorul cuptorului cu microunde iluminat.
  - inchidere etansa a incuierii; deschidere usoara
  - fara mecanism de blocare.
- Interior camera:
  - dimensiuni 327x346x(H)200, capacitate 23 L
  - usor de curatat.
  - fara blocarea farfuriiilor, gratie marginilor rotunjite corespunzator.
  - baza ceramica.
- Utilizare multifunctionala:
  - decongelare.
  - 10 programe implicite.
  - posibilitatea de a salva pana la 100 de programe (pana la 3 etape intr-un singur program).
  - conversia automata a timpului pentru portii duble.
  - sfarsitul ciclului de gatire este semnalizat de o alarma acustica.
  - 4 niveluri de putere.
- Potrivit pentru farfuri rotunde (pana la ø320 mm) si dreptunghiulare
- Timp maxim de functionare: 60 de minute.
- Echipat cu un cablu cu un stecher cu impamantare.
- Greutate: 15,5 kg.



cod	litri	V	W	mm	lei
281444	23	230	1550	509x572x(H)306	1599,00

34 litri  
3000 W  
230 V

 **HENDI**  
Tools for Chefs



281369

## CUPTOR CU MICROUNDE PROGRAMABIL HENDI 3000 W, 34 L

**281369**

- Carcasa si interiorul camerei cu baza ceramica fabricata din otel inoxidabil.
- Panou de comanda usor de citit.
- Comanda electronica.
- Antena magnetron rotativa inferioara si superioara pentru distributie uniforma a energiei, fara disc rotativ.
- Filtru de aer integrat pentru a proteja impotriva factorilor externi si a prafului.
- Puteti selecta programul dorit pe panoul tactil.
- Usa cu geam mare pentru observarea proceselor din interiorul iluminat al cuptorului cu microunde.
- Inchidere stransa a zavorului; deschidere simpla - fara mecanism de blocare.
- Interior camera:
  - dimensiuni 360x409x(H)225 mm, capacitate 34 L.
  - usor de curatat.
  - fara blocarea farfuriilor, gratie marginilor rotunjite corespunzator.
  - baza ceramica.
- Utilizare multifunctionala:
  - decongelare.
  - 10 programe implicite.
  - posibilitatea de a salva pana la 100 de programe (pana la 3 etape intr-un singur program).
  - conversia automata a timpului pentru portii duble.
  - sfarsitul ciclului de gatire este semnalizat de o alarma acustica.
- Puterea microundelor: 1800 W.
- Potrivit pentru farfuriile rotunde (pana la  $\varnothing$ 355 mm) si dreptunghiulare
- Timp maxim de functionare: 60 de minute.
- Echipat cu un cablu cu un stecar cu impamantare.
- Greutate: 32,3 kg.

cod	V	W	mm	lei
281369	230	3000	572x520x(H)363	<b>4299,00</b>





18 L  
3000 W  
230 V

**HENDI**  
Tools for Chefs



281376

## CUPTOR CU MICROUNDDE PROGRAMABIL CU USB HENDI 3000 W, 18 L

**281376**

- Carcasa si interiorul camerei cu baza ceramica fabricata din otel inoxidabil.
- Panou de comanda tactil usor de citit, cu butoane si afisaj digital, care indica timpul si puterea.
- Comanda electronica.
- Antena magnetron rotativa inferioara si superioara pentru distributie uniforma a energiei, fara disc rotativ.
- Filtru de aer si grasime integrat pentru a proteja impotriva factorilor externi.
- Un sistem special care va reaminteste sa curatati filtrul.
- Puteti selecta programul dorit pe panoul de comanda cu butoane.
- Utilizare multifunctionala:
  - decongelare.
  - 10 programe implicite.
  - 10 niveluri de putere.
  - posibilitatea de a salva pana la 100 de programe, inclusiv incarcarea (de la panoul de comanda prin intermediul unui port USB) pana la 20 de programe personalizate, multietajate.
  - conversie automata a timpului pentru portiuni duble sau triple.
- sfarsitul ciclului de gatire este semnalat de o alarma acustica. Posibilitatea de a modifica avertizarea sonora sau de a o opri complet.
- usa cu geam mare pentru observarea proceselor din interiorul iluminat al cuptorului cu microunde.
- inchidere stransa cu incuietoare; deschidere usoara - fara mecanism de blocare.
- Interior camera:
  - dimensiuni 330x310x(H)175, capacitate 18 L.
  - usor de curatat.
  - fara blocarea farfuriilor datorita marginilor rotunjite corespunzator.
  - baza ceramica.
- Puterea microundelor: 3000 W. Potrivit pentru farfuriile rotunde (pana la ø300 mm) si dreptunghiulare.
- Timp maxim de functionare: 60 de minute.
- Echipat cu un cablu cu un stecher cu impamantare.
- Card USB furnizat, software inclus.
- Greutate: 31,8 kg.

cod	litri	V	W	mm	lei
281376	18	230	3000	563x420x(H)340	<b>4239,00</b>



Cod 281710 281352 281444 281369 281376

### GATIT SI PROGRAMARE

Control	electromecanic	electromecanic	electronic	electronic	electronic
Numarul de programe/etape	9/1	1/1	100/3	100/3	100/3
Numarul de niveluri de putere	9	1	4	4	10
Timp maxim	35 min	6 min	60 min	60 min	60 min

### ECHIPAMENT STANDARD

Sursa de microunde	antena magnetronului superior cu arbore rotativ	antena magnetron rotativa mai joasa	antena magnetron rotativa mai joasa	antena magnetron rotativa inferioara si superioara	antena magnetron rotativa inferioara si superioara
Numarul de magnetroni	1	1	1	2	2
Filtru de aer	DA	DA	DA	DA	DA
Port USB	-	-	-	DA	DA
Accesorii suplimentare	DA - gratar	-	-	-	-

### DIMENSIUNI

Dimensiuni externe	440x330x(H)259 mm	511x432x(H)311 mm	511x432x(H)311 mm	574x528x(H)368 mm	563x420x(H)340 mm
Dimensiunile camerei	304x306x(H)206 mm	327x346x(H)200 mm	327x346x(H)200 mm	360x409x(H)225 mm	330x310x(H)175 mm
Capacitatea camerei	20 l	23 l	23 l	34 l	18 l
Diametrul maxim al vasului	280 mm	320 mm	320 mm	355 mm	300 mm

### PARAMETRI TEHNICI

Putere de intrare	1050 W	1550 W	1550 W	3000 W	3000 W
Tensiune	230 V	230 V	230 V	230 V	230 V
Greutate	11,1 kg	15,1 kg	15,5 kg	32,3 kg	31,8 kg
Lei	<b>529,99</b>	<b>1449,00</b>	<b>1599,00</b>	<b>4299,00</b>	<b>4239,00</b>

### TIMPUL DE GATIRE vs PUTEREA APARATELOR

Putere	700	1000	1100	1400	1800
	0:35	0:25	0:22	0:18	0:12
	1:05	0:52	0:48	0:37	0:27
	1:35	1:14	1:06	0:57	0:39
	2:05	1:39	1:29	1:10	0:52
	5:00	4:03	3:34	2:50	2:10
	10:00	8:15	7:23	5:40	4:00



## CUPTOR CU PREPARARE ACCELERATA HENDI SPEEDOVEN X90

**NOU**

Potrivit pentru o gama variata de preparate

Nu necesita instalarea unei hote

Dimensiuni compacte

Instalare usoara

De 10 ori mai rapid decat cuptoarele traditionale

Asigura repetabilitatea rezultatelor cu ajutorul celor 20 de programe instalate

Utilizeaza 3 tehnologii pentru preparare rapida: Microunde, convecție, aer cald cu impact

Usor de utilizat, versatil, permite pregatirea alimentelor intr-un timp foarte scurt

Interval de temperatura: 25°C - 280°C  
Setare putere microunde: 0- 100%  
Aer cald cu impact: 10 trepte

Croissante

35 s



Bruschette

45 s



Burger cu cartofi prajiti

90 s



Aripioare de pui

105 s



## CUPTOR CU PREPARARE ACCELERATA HENDI SPEEDOVEN X90

- Carcasa fabricata din otel inoxidabil.
- Dimensiuni interne ale camerei: 305x305x(H)185 mm.
- Convertorul catalitic incorporat elimina necesitatea unei hote de extractie – cuptorul poate fi utilizat in orice loc, imediat dupa conectare.
- Procesare expres datorita combinatiei de 3 tehnologii:
  - microunde,
  - convectie,
  - gatire cu aer cald cu impact: preparatul este gatit cu ajutorul jeturilor de aer cald.
- Nu este nevoie de pre-tratare (atat proaspata, cat si congelata) – reducand pierderile de produs si timpul de pregatire.
- Functie de pornire rapida.
- Panou de comanda de 5 inch cu ecran tactil.
- Port USB integrat pentru incarcarea retetelor.
- Cu cronometru de 20 de minute.



- 20 de retete implicite; posibilitate de a crea pana la 1024
- de programe cu pana la 15 pasi fiecare.
- Interval de temperatura: 25-280°C.
- Interval de setare microunde: 0-100%.
- Aer cu impact: 10 niveluri de putere.
- Clasificare impermeabilitate: IPX3.
- Un set complet de accesorii:
  - baza rotunda de pizza,
  - cos din teflon perforat (pentru gatit),
  - perna rotunda perforata,
  - placa grill,
  - lopata cuptor
- Limbi sistem de operare: poloneza, engleza, germana, olandeza, spaniola, franceza, italiana, rusa, chineza.

cod	V	W	mm	lei
281260	230	3500	460x675x(H)661	25749,00

## TAVA PENTRU CUPTOR, NEADERENTA, RANFORSATA

- Recomandat in special pentru HENDI SPEEDOVEN X90.
- Margini cu armatura din otel inoxidabil acoperita cu PTFE – sigura pentru utilizare in cuptoarele cu microunde.
- Fabricat din PTFE.
- Rezistenta la temperatura: 260°C.
- Potrivit pentru masina de spalat vase.
- Este disponibila si versiunea perforata (cod: 808351).

cod	mm	lei
808337	290x190x(H)30	162,99
808344	290x290x(H)20	197,99
808351	290x190x(H)30	162,99

**NOU**



808337



808351

## TAVA PENTRU CUPTOR, ANTIADERENTA

- Recomandat in special pentru HENDI SPEEDOVEN X90.
- Fabricat din PTFE.
- Rezistenta la temperatura: 260°C.
- Potrivit pentru masina de spalat vase.

cod	mm	lei
219744	280x280x(H)18	150,99

**NOU**



219744

S.S.  
stainless steel

227060



Vezi filmul



Doi ventilatoare foarte eficiente, distribuind uniform aerul fierbinte

**CUPTOR CONVECTIE H90**

- Carcasa din otel inoxidabil.
- Usa cool-touch cu geam dublu, care poate fi indepartata pentru o curatare usoara.
- Camera partial emailata cu iluminare interioara.
- Incalzire prin 2 elemente de incalzire si 2 ventilatoare.
- Temperatura reglabila de la 50°C la 300°C.
- Cronometru: 0-120 min.
- Se potriveste cu 4 tavi de 438x315 mm.
- Ghidajele interspatiate la: 70 mm.
- Se livreaza cu 4 tavi.

cod	V	W	mm	Lei
227060	230	2670	595x595x(H)570	<b>1899,00</b>
223468	Suport pentru cuptor		595x425x(H)700	<b>1359,00</b>
801970	Gratar pentru cuptor		433x338	<b>74,99</b>
943380	Tava pentru cuptoarele		435x315x(H)8	<b>54,99</b>

Compatibil cu patru tavi din aluminiu



Sticla dubla, rezistenta la caldura



Echipat cu iluminare interioara





227077



### CUPTOR CONVECTIE CU UMIDIFICARE H90S

- Corp din otel inoxidabil, usa cu geam dublu
- Usa detasabila pentru curatare usoara
- In interior este partial emailat, cu iluminare interioara
- Incalzire cu 2 elemente incalzire si 2 ventilatoare
- Temperatura reglabila de la 50°C pana la 300°C
- Umidificare directa, operata manual cu un buton
- Timer reglabil de 0 pana la 120 min
- Potrivit pentru 4 tavi 436x315 mm, distanta intre tavi 70 mm
- 4 tavi incluse (438x315 mm)

Umidificare directa



cod	V	W	mm	lei
227077	230	2670	595x595x(H)570	2229,00
223468	Suport pentru cuptor		595x425x(H)700	1359,00
801970	Gratar pentru cuptor		433x338	74,99
943380	Tava pentru cuptoarele		435x315x(H)8	54,99

Usa detasabila faciliteaza curatarea



Sicla ramane suficient de rece pentru a fi atinsa



Cu clema pentru scoaterea tavilor fierbinti



## CUPTOARE SNACK CONVECTIE

- Solutie ideala pentru unitatile de catering care doresc sa adauge in oferta lor produse proaspete si gustoase.
- Prin dimensiunea compacta si consumul eficient de energie sunt potrivite pentru orice bucatarie.
- Umidificatorul incorporat (modelele selectate) le face potrivite

- chiar si pentru cele mai sofisticate produse
- Corpul si camera de coacere din otel inoxidabil.
- Usa de sticla cu ventilare gravitatonala.
- Sistem de racire pentru comenzi.



TAVI

429x345



Vezi filmul



4x

429x345x(H)9

cod	219737
tip	convectie
control	electromecanic
capacitatea camerei	4 tavi 429x345x(H)9 mm
distanța între tavi	74 mm
dimensiuni	590x695x(H)590 mm
<b>ventilatoare nereversibile</b>	<b>1</b>
termostat	100°C - 260°C electromecanic
putere/alimentare	2,8 kW/230 V
greutate	34 kg
lei	<b>2279,00</b>
<b>SUPPORT</b>	
cod	224670
tip	8 perechi de ghidaje pentru tavi cu dimensiuni de 435x345 si 540x460x700mm
lei	<b>942,99</b>



225967

## DOSPITOR CAPACITATE 8 TAVI 600X400 MM

- Control manual
- Potrivit pentru 225516, 225523, 225059, EKf464N, EKf464NUD, EKf464NTUD
- Distanța între sine 70 mm
- Termostat electromecanic de la 30° C până la 60° C

cod	225967
capacitatea camerei	8 tavi x 600x400 mm
distanța între tavi	70 mm
dimensiuni	795x655x(H)835 mm
termostat electromecanic	30°C - 60°C
alimentare	230 V
putere	2,4 kW
greutate	43,6 kg
lei	<b>6389,00</b>



225929

### CUPTOR CU CONVECTIE, ABUR SI GRATAR 4 X GN 2/3

- Corp si camera din otel inoxidabil de inalta calitate.
- Panou de comanda manual cu butoane pentru functie, temperatura, timp si cantitate de abur.
- Are functii pentru dezghetare, preincalzire, convecție, gratar, abur sau o combinatie a acestor functii.
- Temperatura poate fi setata la 280°C
- Timerul poate fi setat la 120 de minute.
- Convecție prin intermediul a doua elemente de incalzire si un ventilator
- Cu elemente de gratar fry-top.
- Cuptorul se potriveste cu 4 tavi GN 2/3, distanta dintre tavi este de 70 mm.
- Livrat cu 1 grila GN 2/3.
- Convecție 3 kW, gratar: 1,8 kW.
- Incalzitoarele camerei: partea inferioara de 1,6 kW, partea superioara de 0,7 kW.
- Picioare reglabile de la 55 la 75 mm.



224823

cod	V	W	mm	lei
225929	230	3000	625x585x(H)590	5799,00





CUPTOARE PROFESIONALE COMBI-STEAMER



## CUPTOARE CU CONVECTIE 429X345 MM

- Corpul si camera de gatire sunt fabricate din otel inoxidabil AISI 304.
- Usa de sticla, dubla, cu ventilatie gravitationala, deschisa din partea superioara.
- 1 ventilator nereversibil / modelul cu panou de comanda cu ecran tactil este echipat cu 1 ventilator cu functie de inversare automata cu 2 viteze (principal si redus).
- Modele disponibile cu abur indirect sau direct (10 grade).
- Racirea comenzilor.
- Modelele cu panouri de comanda cu ecran tactil sunt echipate

- cu lampa LED, port USB pentru incarcarea datelor HACCP, 99 de programe ce pot fi personalizate si, optional, cu conexiune Wi-Fi pentru actualizari de software.
- Capacitatea camerei: 4 tavi cu dimensiuni de 429x345x(H)9 mm (incluse in set, fabricate din aluminiu).
- Clasificare impermeabila: IPX 3.
- Interval de temperatura: de la 30 sau 100°C (in functie de model) la 260°C.
- Spatiere suport tava: 74 mm.



EKF423NU



4x  
429x345

cod	EKF423NP	EKF423NU	EKF423TUD	EKF423NM
tip	convectie	cu umidificare	cu umidificare	multifunctional
control	electromecanic	electromecanic	touchpad	electromecanic
	-	abur indirect, manual, controlat cu un buton, fara pulverizare pe incalzitoare (recipient amplasat in spatele deflectorului).	abur direct	8 moduri: coacere statica (incalzitior superior, incalzitior inferior, ambele incalzitioare), coacere statica cu convectie, grill cu convectie, coacere prin convectie, decongelare
termostat	100°C - 260°C	100°C - 260°C	30°C - 260°C	100°C - 260°C
distanța între tavi	74 mm	74 mm	74 mm	74 mm
dimensiuni	590x709x(H)589 mm	590x709x(H)589 mm	590x709x(H)589 mm	590x709x(H)589 mm
ventilatoare	1 ventilatoare nereversibile	1 ventilatoare nereversibile	1 ventilator cu auto-reverse, 2 viteze	1 ventilatoare nereversibile
putere/alimentare	3,1 kW/230 V	3,1 kW/230 V	3,15 kW/230 V	2,6 kW/230 V
greutate	33 kg	34 kg	38 kg	36,4 kg
lei	2849,00	3899,00	5999,00	3799,00
<b>SUPPORT</b>				
cod	224670 <b>NOU</b>	224670 <b>NOU</b>	224670 <b>NOU</b>	224670 <b>NOU</b>
tip	8 perechi de ghidaje pentru tavi cu dimensiuni de 435x345 si 540x460x700 mm			
lei	942,99	942,99	942,99	942,99



**CUPTOARE MIXTE CU ABURI GN 1/1**

- Carcasa si camera fabricate din otel inoxidabil AISI 304.
- Ghidaje solide in forma de „L”.
- Usa vitrata, cu 2 strat-uri, ventilata prin gravitatie, care se deschide de sus.
- 2 ventilatoare cu inversare automata.
- Racire a comenzilor.
- Protectie impotriva supraincalzirii.
- Iluminare cu LED-uri.

- Capacitate camera: 4 tavi GN 1/1 530x325 mm (nu sunt furnizate).
- Grad de protectie IPX 3.
- Functie de preincalzire pana la 180°C.
- Dista-nta dintre lamele: 73 mm.
- EKF411NTUD - echipat cu port USB pentru descarcarea datelor HACCP, programabil pentru 99 de programe si optional, echipat cu conexiune wi-fi pentru actualizari de software.



EKF411NUD

4x  
GN 1/1

cod	EKF411NUD	EKF411NTUD
tip	cu umidificare electromecanic	cu umidificare touchpad
control	abur direct, 5 trepte, reglat cu un buton	abur direct, 10 grade, controlat electronic, programabil: 99 de programe, fiecare in cate 4 pasi
termostat	100°C – 260°C	30°C – 260°C
dista-nta intre tavi	73 mm	73 mm
dimensiuni	784x752x(H)634 mm	784x752x(H)634 mm
<b>ventilatoare</b>	2 ventilatoare cu functie de inversare automata	2 ventilatoare cu functie de inversare automata, cu 2 viteze
putere/alimentare	6,4 kW/400 V	6,4 kW/400 V
greutate	58 kg	58 kg
lei	8099,00	9699,00
<b>SUPPORT</b>		
cod	224441 <b>NOU</b>	224441 <b>NOU</b>
tip	6 perechi de ghidaje pentru tavi GN 1/1, dim. 790x520x700 mm	
lei	1259,00	1259,00

## CUPTOARE DE BRUTARIE CU CONVECTIE SI UMIDIFICATOR DE 600X400 MM

- Corpul si camera de gatit sunt fabricate din otel inoxidabil AISI 304.
- Ghidaje robuste in forma de L pentru tavi.
- Usa de sticla, dubla, cu ventilatie gravitacionala, deschisa din partea superioara.
- 2 ventilatoare nereversibile sau cu functie de inversare automata - in functie de model.
- Modele disponibile cu abur indirect sau direct (5 sau 10 trepte).
- Protectie la supraincalzire.
- Lumina LED.
- Modelele cu panouri de comanda cu ecran tactil sunt echipate cu lampa cu LED, port USB pentru incarcarea datelor HACCP, 99 de programe care pot fi personalizate si, optional, cu conexiune wi-fi pentru actualizari de software.
- Interval de temperatura: de la 30 sau 100°C (in functie de model) la 260°C.
- Modelul EKF464NTUD este dotat cu functia de preincalzire pana la 180°C.
- Spatiere suport tava: 83 mm, model EKF464N - 73 mm.



EKF464NUD



4x  
600x400

cod	EKF464N	EKF464NUD	EKF464NTUD
tip	cu umidificare	cu umidificare	cu umidificare
control	electromecanic	electromecanic	touchpad
	abur indirect, manual, controlat cu un buton, fara pulverizare pe incalzitoare (recipient amplasat in spatele deflectorului)	abur direct - apa pulverizata direct pe ventilator, 5 trepte, controlata cu un buton	abur direct, 10 trepte, controlat electronic, programabil: 99 de programe, fiecare in cate 4 pasi, panou de comanda cu ecran tactil si pictograme colorate
termostat	100°C - 260°C	100°C - 260°C	30°C - 260°C
distanța între tavi	73 mm	83 mm	83 mm
dimensiuni	783x755x(H)634 mm	783x755x(H)634 mm	783x755x(H)634 mm
ventilatoare	2 ventilatoare nereversibile	2 ventilatoare cu functie de inversare automata	2 ventilatoare cu functie de inversare automata, cu 2 viteze
putere/alimentare	3,4 kW/230 V	6,4 kW/400 V	6,4 kW/400 V
greutate	58 kg	58 kg	58 kg
lei	<b>5899,00</b>	<b>7999,00</b>	<b>8999,00</b>
<b>SUPORT</b>			
cod	224434 <b>NOU</b>	224434 <b>NOU</b>	224434 <b>NOU</b>
tip	6 perechi de ghidaje pentru tavi 600x600, dim. 760x520x700 mm		
lei	<b>1209,00</b>	<b>1209,00</b>	<b>1209,00</b>



## CUPTOR CONVECTIE CU ABURI – EVOLUTION NEXT 5 X GN 2/3, ELECTRIC, CU PULVERIZARE DIRECTA, CONTROLAT ELECTROMECHANIC



→ | 55 cm | ←



**5x**  
GN 2/3

cod	EKF523NUD
distanța între tavi	80 mm
dimensiuni	550x754x(H)662 mm
<b>ventilatoare cu reverse</b>	1
termostat	100-270°C
putere/alimentare	3,2 kW/230 V
greutate	40 kg
lei	<b>6999,00</b>
<b>SUPPORT</b>	
cod	237977 <b>NOU</b>
tip	6 perechi de ghidaje pentru tavi GN 2/3, dim. 550x465x(H)700 mm
lei	<b>1579,00</b>

- Recomandat pentru utilizarea în unități profesionale de catering, în special în bucătări deschise, cantine, baruri, cantine.
- Design elegant, italian.
- Lățimea mică (55 cm) permite aparatului să fie amplasat și în spații mici, de ex. într-un magazin sau la o benzinărie.
- Camera fabricată integral din oțel inoxidabil AISI 304 de înaltă calitate.
- Ghidaje glisante detașabile pentru recipientele GN.
- Sticla dublă, rezistentă la căldură, cu garnitură.
- Aburul este generat direct prin pulverizarea apei pe ventilator.
- Curățare ușoară.
- Usa cu balamale în partea dreaptă.
- Iluminat cu LED intern, eficient energetic.
- Racordarea la apă: 3/4".
- Scurgere pentru canalizare: ø30 mm.
- Evacuare internă.
- Spălare semiautomată ca opțiune.
- Produsul este disponibil și într-o versiune maritimă cu tensiune și caracteristici de siguranță modificate.
- Dimensiuni: 550x754x(H)662 mm.
- Greutate: 40 kg.
- Ghidaje interspatiate la: 80 mm.
- Putere: 3,2 kW.
- Tensiune 230 V.
- Capacitate: 5 tavi GN 2/3.
- 1 ventilator cu inversare automată.
- Clasa impermeabilității: IPX4.

**CUPTOR CONVECTIE CU ABURI – EVOLUTION NEXT 5 X GN 2/3, ELECTRIC, CU PULVERIZARE DIRECTA SI UN PANOU DE COMANDA CU ECRAN TACTIL**



**SUPER  
COMPACT**  
DOAR 55 CM

→ | 55  
cm | ←



**5x**  
GN 2/3

kod	EKF523NTUD
distanța între tavi	80 mm
dimensiuni	550x754x(H)662 mm
<b>ventilatoare cu reverse</b>	1
termostat	30-270°C
putere/alimentare	3,2 kW/230 V
greutate	40 kg
lei	<b>9099,00</b>
<b>SUPPORT</b>	
cod	237977 <b>NOU</b>
tip	6 perechi de ghidaje pentru tavi GN 2/3, dim. 550x465x(H)700mm
lei	<b>1579,00</b>

- Recomandat pentru utilizarea în unități profesionale de catering, în special în bucătării deschise, cantine, baruri, cantine.
- Design elegant, italian.
- Latimea mica (55 cm) permite aparatului sa fie amplasat si in spatii mici, de ex. într-un magazin sau la o benzinarie.
- Camera fabricata integral din otel inoxidabil AISI 304 de inalta calitate.
- Ghidaje glisante detasabile pentru recipientele GN.
- Sticla dubla, rezistenta la caldura, cu garnitura.
- Aburul este generat direct prin pulverizarea apei pe ventilator.
- Curatare usoara.
- Usa cu balamale in partea dreapta.
- Iluminat cu LED intern, eficient energetic.
- Racordarea la apa: 3/4".
- Scurgere pentru canalizare: ø30 mm.

- Evacuare internă.
- Spalare semiautomata ca optiune.
- Produsul este disponibil si într-o versiune maritima cu tensiune si caracteristici de siguranta modificate.
- Dimensiuni: 550x754x(H)662 mm.
- Greutate: 40 kg.
- Ghidaje interspatiate la: 80 mm.
- Putere: 3,2 kW.
- Tensiune 230 V.
- Capacitate: 5 tavi GN 2/3.
- 1 ventilator cu inversare automata.
- Clasa impermeabilitate: IPX4.





CUPTOARE PROFESIONALE COMBI-STEAMER



## MANUSI

- Manusile de protecție HENDI sunt echipamente de protecție personală certificate și sunt conforme cu cerințele REGULAMENTULUI PARLAMENTULUI EUROPEAN ȘI ale CONSILIULUI (UE) 2016/425 din 9 martie 2016 privind echipamentul personal de protecție și abrogând Directiva Consiliului 89/686/CEE. Regulamentul specifică categoriile de pericole de la I la III. Pentru fiecare categorie au fost specificate metode și cerințe legate de certificare. Manusile de protecție HENDI sunt echipamente de protecție de categoria II.
- Acestea poartă marcajul CE ca echipament de protecție personală certificat.
- Toate manusile noastre îndeplinesc cerințele standardului general EN 420 Cerințe generale pentru manusi
- Acestea asigură:
  - protecție termică în conformitate cu EN 407 Manusi de protecție și alte echipamente de protecție a mâinilor împotriva riscurilor termice (caldura și/sau foc) și

- protecție împotriva pericolelor mecanice în conformitate cu EN 388 Manusi de protecție împotriva riscurilor mecanice și în conformitate cu EN 13997 Imbracaminte de protecție - Proprietăți mecanice
- Determinarea rezistenței la tăiere cu un obiect ascuțit ascuțit.



11 XXXX

Protecție împotriva pericolelor termice au o pictogramă și cifre care specifică gradul de protecție asigurat, de ex.:

- primul număr descrie rezistența la foc, al doilea este rezistența la căldura de contact, al treilea este rezistența la căldura de convecție și a patra rezistența la căldura rezistentă la radiații, a cincea rezistența minoră la stropire cu metal topit, a șasea rezistența la cantități mari de metal topit.



### MANUSI PROTECȚIE CUPTOR, BUMBAC - 2 BUCATI

cod	ambalat pe	mm	lei
556603	2	(L)350	34,99



556603



### MANUSI PROTECȚIE CUPTOR, FIBRA DE STICLA - 2 BUCATI

cod	ambalat pe	mm	lei
556627	2	(L)360	79,99



556627



556610



### MANUSI PROTECȚIE CUPTOR - 2 BUCATI

- Lungi, pentru protecție braț

cod	ambalat pe	mm	lei
556610	2	(L)380	49,99





## MILLENNIAL CUPTOARE CU CONVECTIE INTELEGENTE



### Airflowlogic™

O solutie inovatoare constand intr-o reproiectare completa a deflectorului. Efectul este o circulatie imbunatatita a aerului care asigura cele mai bune rezultate in gatit uniform pe fiecare nivel si in fiecare zona a unui recipient GN sau al unei tavi de 600x400 mm.

Airflowlogic™ garanteaza o calitate excelenta a procesarii alimentelor in cuptoare.

Un cuptor Millennial cu brevet Airflowlogic™ ofera cea mai buna performanta in bucatarie.



### Drylogic™

Un sistem inovator de uscare pentru camera cuptorului. Prin verificarea constanta a parametrilor, cuptoarele Millennial TS au control deplin asupra mentinerii nivelului corect de umiditate in camera de gatit. O supapa speciala controlata de un computer controleaza schimbul de aer in camera si elimina umiditatea excesiva.

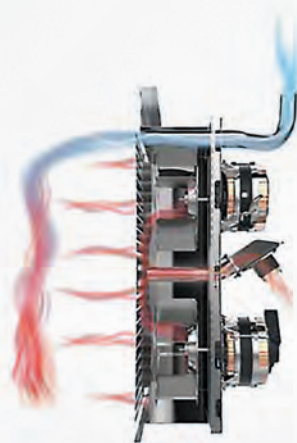



### Humilogic™

Nou sistem de umidificare care alimenteaza apa direct din ventilator. Oferă un nivel ridicat de umiditate și un consum mult mai mic de apă. În acest sistem, aburul ajunge până la capăt în alimentele gătite, ceea ce îi sporește gustul și aroma naturală. Humilogic™ este soluția pentru bucătării de top care se așteaptă la cele mai bune rezultate.

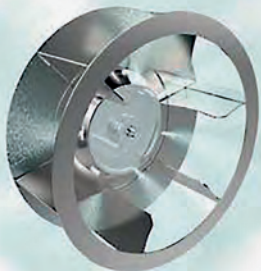

### Sistem automat de spalare

Fiecare cuptor vine standard cu 4 programe de spalare: ECO, NORMAL, INTENS, CLATIRE, adaptate la diferitele niveluri de murdărie ale camerei. Economie de apă de până la 30% cu noul cap de spalat – nu numai că economisiți bani, dar contribuiți și la protejarea mediului.



### 3 versiuni de control:

#### Millennial Smart

– electromecanic cu 3 butoane

#### Millennial Black Mask

– ecran tactil monocrom de 7"

#### Millennial Touch Screen

– ecran tactil TFT color de 7"



## CUPTOARE CU CONVECTIE MILLENNIAL SMART GASTRO PENTRU GASTRONOMIE SI MILLENNIAL SMART BAKERY PENTRU COFETARIE SI PANIFICATIE, CONTROL ELECTROMECHANIC, ELECTRIC SI GAZ



Reglarea timpului de la 10 la 120 de minute sau funcționare NON STOP  
 Reglarea temperaturii în intervalul 100°C-270°C în varianta electrică și 100°C-260°C în versiunea pe gaz  
 Controlul nivelului de abur în 5 trepte



- O serie de cuptoare noi cu abur cu convecție extrem de ușor de utilizat, Millennium Smart.
- Serie de cuptoare Smart Gastro pentru gastronomie – o camera de gătit mai mică cu sine de ghidare pentru recipiente GN 1/1.
- Serie de cuptoare Smart Bakery pentru cofetării și brutării – o camera de gătit mai mare cu sine de ghidare pentru tavi de 600x400 mm.
- Ambele serii au cuptoare în patru dimensiuni. Această gamă largă va permite să alegeți un cuptor ideal pentru a pregăti de la 72 la 480 de mese pe zi.
- Cuptoarele din fiecare grupă sunt disponibile în versiuni electrice și pe gaz.
- Control electromecanic cu 3 butoane. Setarea ușoară a celor mai importanți parametri, nefiind nevoie de pregătire specială. Alimentele pot fi preparate în aer uscat, fierbinte sau folosind controlul nivelului de abur în 5 trepte. Toate opțiunile sunt disponibile și în funcția de convecție.

### PANOU DE CONTROL:

- Reglarea timpului de la 10 la 120 de minute sau funcționare NON STOP
- Reglarea temperaturii în intervalul 100°C-270°C în varianta electrică și 100°C-260°C în versiunea pe gaz
- Controlul nivelului de abur în 5 trepte
- Abur este generat prin pulverizare directă cu apă cu control al nivelului de abur în 5 trepte
- Usa de siguranță – blocarea deschiderii la 60°, 90°, 120° și 180° previne arsurile operatorului din cauza miscării necontrolate a usii după deschidere
- Usa camerei are geam dublu și iluminarea LED facilitează observarea proceselor din cuptor
- Sticla exterioară răcită prin gravitație pentru o siguranță sporită a personalului
- Usa cu balamă dreaptă
- Garnitura de usa din silcon gros și rezistent la căldură, montată



- in carcasa cuptorului, usor de inlocuit fara a apela la service
- Carcasa izolata a cuptorului nu numai ca economiseste energie electrica, dar maresc si siguranta personalului din bucatarie
- O cuva sub usa impiedica scurgerea aburului condensat, in special in ciclul mixt si abur. O podea uscata sub si in fata cuptorului garanteaza conditiile de lucru sigure pentru personal
- Camera cuptorului realizata din otel inoxidabil AISI 304 de inalta calitate
- Camera de gatit cu culturi rotunjite pentru curatarea usoara a cuptorului
- Corp din otel inoxidabil
- Grad de protectie la apa: IPX4 – versiuni electrice si IPX3 – versiuni pe gaz
- Picioarele reglabile asigura o nivelare perfecta a cuptorului, cu efecte directe asupra functionarii acestuia
- Este necesar racordarea la curent electric, apa tratata, canalizare

#### CUPTOARE PE GAZ:

- adaptat din fabrica pentru gaze naturale
- prevazut cu duze suplimentare pentru propan-butan
- racord gaz: 1/2"



## CUPTOARE CU CONVECTIE MILLENNIAL SMART GASTRO PENTRU GASTRONOMIE

TAVI

GN 1/1

NOU

Cu pompa de apa - extrage apa dintr-un rezervor exterior



### Electric

	5x GN 1/1	5x GN 1/1	7x GN 1/1	11x GN 1/1	20x carucior - GN 1/1
kod	MKF511S	MKF511SKKPU	MKF711S	MKF1111S	MKF2011S
distanța între tavii	68 mm	68 mm	68 mm	68 mm	66 mm
dimensiuni	730×784×(H)700 mm	730×784×(H)700 mm	730×784×(H)850 mm	730×785×(H)1130 mm	930×971×(H)1900 mm
<b>ventilatoare cu reverse</b>	1	1	2	2	4
putere/alimentare	7,8 kW/400 V	7,8 kW/400 V	10,4 kW/400 V	15,4 kW/400 V	31 kW/400 V
greutate	78,4 kg	78,4 kg	96 kg	113,8 kg	247,2 kg
lei	9699,00	12849,00	10549,00	14999,00	37999,00
<b>SUPPORT</b>					<b>CARUCIOR</b>
cod	229521	229521	229521	220795	EKCR20TC
dimensiuni	610×560×(H)770 mm	610×560×(H)770 mm	610×560×(H)770 mm	610×560×(H)620 mm	660×560×(H)1704 mm
tip	suport pentru 5 containere GN 1/1	suport pentru 5 containere GN 1/1	suport pentru 5 containere GN 1/1	suport pentru 5 containere GN 1/1	suport pentru 20 containere GN 1/1
lei	1699,00	1699,00	1699,00	1749,00	10899,00

TAVI

GN 1/1



### Gaz

	5x GN 1/1	7x GN 1/1	11x GN 1/1
kod	MKF511GS	MKF711GS	MKF1111GS
distanța între tavii	68 mm	68 mm	68 mm
dimensiuni	730×855×(H)801 mm	730×855×(H)951 mm	730×855×(H)1231 mm
<b>ventilatoare cu reverse</b>	1	2	3
putere gaz	9,3 kW	13,5 kW	17,5 kW
putere/alimentare	300 W/230 V	500 W/230 V	700 W/230 V
greutate	89 kg	108,5 kg	141 kg
lei	18999,00	20949,00	25999,00
<b>SUPPORT</b>			
cod	229521	229521	220795
dimensiuni	610×560×(H)770 mm	610×560×(H)770 mm	610×560×(H)620 mm
tip	suport pentru 5 containere GN 1/1	suport pentru 5 containere GN 1/1	suport pentru 5 containere GN 1/1
lei	1699,00	1699,00	1749,00

## CUPTOARE CU CONVECTIE MILLENNIAL SMART BAKERY PENTRU COFETARIE SI PANIFICATIE

TAVI

600x400



### Electric



4x

600x400



6x

600x400



10x

600x400

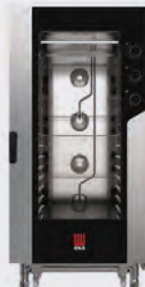

16x

carucior - 600x400

cod	MKF464S	MKF664S	MKF1064S	MKF1664S
distanța între tavii	80 mm	80 mm	80 mm	80 mm
dimensiuni	850x1044x(H)700 mm	850x1035x(H)850 mm	850x1035x(H)1130 mm	930x1041x(H)1900 mm
<b>ventilatoare cu reverse</b>	1	2	3	4
putere/alimentare	7,8 kW/400 V	10,4 kW/400 V	15,5 kW/400 V	31 kW/400 V
greutate	92,4 kg	108,2 kg	140,4 kg	247,2 kg
lei	10999,00	13249,00	17999,00	41049,00
<b>SUPPORT</b>				<b>CARUCIOR</b>
cod	229538	229538	220894 <b>NOU</b>	EKCR16TC
dimensiuni	710x640x(H)770 mm	710x640x(H)770 mm	710x640x(H)620 mm	740x560x(H)1704 mm
tip	suporturi pentru 5 tavii 600x400 mm	suporturi pentru 5 tavii 600x400 mm	suporturi pentru 5 tavii 600x400 mm	suporturi pentru 20 tavii 600x400 mm
lei	1749,00	1749,00	1799,00	10099,00

TAVI

600x400



### Gaz



4x

600x400



6x

600x400



10x

600x400

cod	MKF464GS	MKF664GS	MKF1064GS
distanța între tavii	80 mm	80 mm	80 mm
dimensiuni	850x1041x(H)801 mm	850x1041x(H)951 mm	850x1041x(H)1231 mm
<b>ventilatoare cu reverse</b>	1	2	3
putere gaz	9,3 kW	13,5 kW	17,5 kW
putere/alimentare	300 W/230 V	500 W/230 V	700 W/230 V
greutate	102 kg	123 kg	158 kg
lei	18999,00	20999,00	26249,00
<b>SUPPORT</b>			
cod	229538	229538	220894 <b>NOU</b>
dimensiuni	710x640x(H)770 mm	710x640x(H)770 mm	710x640x(H)620 mm
tip	suporturi pentru 5 tavii 600x400 mm	suporturi pentru 5 tavii 600x400 mm	suporturi pentru 5 tavii 600x400 mm
lei	1749,00	1749,00	1799,00



## CUPTOARE CU CONVECTIE MILLENNIAL BLACK MASK GASTRO PENTRU GASTRONOMIE SI MILLENNIAL BLACK MASK BAKERY PENTRU COFETARIE SI PANIFICATIE, PANOU DE COMANDA DIGITAL MONOCROM, ELECTRIC SI GAZ



### Panoul de control tactil negru de 7"

– controlul electronic permite setarea foarte precisa a parametrilor necesari de gatit. Toti parametrii si functiile sunt indicati fie numeric, fie prin pictograme.

- O serie de cuptoare moderne cu convecție Millennium Black Mask. Numele nu este un accident - panoul de control tactil negru de 7" dispăre complet pe fundalul cadrului negru al usii atunci când cuptorul este oprit.
- Seria de cuptoare Black Mask Gastro pentru gastronomie – o camera de gatit mai mica cu sine de ghidare pentru recipiente GN 1/1.
- Seria de cuptoare de panificatie Black Mask pentru cofetarii si brutarii – o camera de gatit mai mare cu sine de ghidare pentru tavi de 600x400 mm.
- Ambele grupuri au cuptoare in patru dimensiuni. Aceasta gama larga va permite sa alegeti un cuptor ideal pentru a pregăti de la 72 la 480 de mese pe zi.
- Cuptoarele din fiecare grupa sunt disponibile in versiuni electrice si pe gaz.

**1-POINT PROBE:** O sonda cu un singur punct pentru determinarea si masurarea temperaturii din interiorul produsului gatit.

**PANOU DE CONTROL TACTIL NEGRU DE 7":** Controlul electronic permite setarea foarte precisa a parametrilor necesari de gatit. Toti parametrii si functiile sunt indicati fie numeric, fie prin pictograme.

Panoul de control al cuptoarelor Millennium Black Mask va permite sa utilizati multe caracteristici foarte interesante si inovatoare:



**Airflowlogic™** – O solutie inovatoare constand intr-o reprojectare completa a deflectorului. Efectul este o circulatie imbunatatita a aerului care asigura cele mai bune rezultate in gatit uniform pe fiecare nivel si in fiecare zona a unui recipient GN sau al unei tavi de 600x400 mm. Airflowlogic™ garanteaza o calitate excelenta a procesarii alimentelor in cuptoare. Un cuptor Millennium cu brevet Airflowlogic™ ofera cea mai buna performanta in bucatarie.



**Humilogic™** – Nou sistem de umidificare care alimenteaza apa direct din ventilator. Oferă un nivel ridicat de umiditate si un consum mult mai mic de apa. In acest sistem, aburul ajunge pana la capăt in alimentele gatite, ceea ce ii sporeste gustul si aroma naturala. Humilogic™ este solutia pentru bucatarii de top care se asteapta la cele mai bune rezultate.

### SISTEM DE SPALARE AUTOMAT (OPTIONAL montat doar din fabrica):

Instalat standard in cuptoarele electrice Gastro si Compact.

4 programe de spalare: ECO, NORMAL, INTENS, CLATIRE, adaptate la diferitele niveluri de murdarire ale camerei. Economii de apa de pana la 30% cu capul de spalat NOU – nu numai ca economisiti bani, dar contribuiti si la protejarea mediului. Optional in cuptoarele cu gaz.

**PRE-INCALZIRE:** preincalzirea camerei de gatit la temperatura cu 30 de grade mai mare decat temperatura setata

**MENTINERE:** mentinerea alimentelor la o temperatura suficient de ridicata imediat dupa finalizarea ciclului de gatire

**RACIRE:** racirea rapida a camerei de gatit pentru a incepe un alt proces de gatit care necesita o temperatura mult mai scazuta

**USB port** pentru descarcare si incarcare rapida si usoara a retetelor de gatit si a datelor HACCP

**DOSPIRE:** cuptorul serveste drept camera de dospire – o functie utila in versiunile de panificatie si cofetarie

**MENTINERE LA CALD:** cuptorul serveste ca dulap de mentinere la cald, mentine temperatura corecta si nivelul adecvat de umiditate al vaselor pana cand sunt servite.

Pornire intarziata a cuptorului cu pana la 24 de ore – o functie utila pentru a pregăti cuptorul sau vasul inainte ca personalul sa vina la serviciu.



O carte de bucate cu 100 de retete, fiecare cu 10 pasi posibili care trebuie definiti consecutiv

3 viteze ale ventilatorului: maxim 2800 rpm, minim 1500 rpm

Putere ventilator: normal, semi-static, 1/2 putere

Gatei DELTA T

Controlul nivelului de abur in 10 trepte.

Reglarea temperaturii in intervalul 30-270°C pentru cuptoarele

electrice si 30-260°C pentru cuptoarele pe gaz

Timp de functionare reglabil pana la 11 h, 59 min sau functionare

continua NON STOP

Posibilitatea de stocare a datei si orei curente

#### ALTE CARACTERISTICI ALE CUPTOARELOR MILLENNIAL

##### BLACK MASK:

- Usa de siguranta - blocarea deschiderii la 60°, 90°, 120° si 180° previne arsurile operatorului din cauza miscarii necontrolate a usii dupa deschidere
- Usa camerei cu geam dublu si iluminarea LED faciliteaza observarea proceselor din cuptor
- Sticla exterioara racita prin gravitatie pentru o siguranta sporita a personalului
- Usa cu balama dreapta. Este posibil sa comandati cuptorul cu balama din stanga - optiune contra cost. Optiune disponibila numai din fabrica. Nu este posibila nicio modificare ulterioara a usii.

- Garnitura de usa din silicon gros si rezistent la caldura, montata in carcasa cuptorului, usor de inlocuit fara a apela la service
- Carcasa izolata a cuptorului nu numai ca economiseste energie electrica, dar maresta si siguranta personalului din bucatarie
- O cuva sub usa impiedica scurgerea aburului condensat, in special in ciclul mixt si abur. O podea uscata sub si in fata cuptorului garanteaza conditii de lucru sigure pentru personal
- Camera cuptorului realizata din otel inoxidabil AISI 304 de inalta calitate
- Camera de gatit cu colturi rotunjite pentru curatarea usoara a cuptorului
- Corp din otel inoxidabil
- Grad de protectie la apa: IPX4 - versiuni electrice si IPX3 - versiuni pe gaz
- Picioarele reglabile asigura o nivelare perfecta a cuptorului, cu efecte directe asupra functionarii acestuia
- Este necesar racordarea la curent electric, apa tratata, canalizare

##### Cuptoare cu gaz:

- adaptat din fabrica pentru gaze naturale
- prevazut cu duze suplimentare pentru propan-butan
- racord gaz: 1/2"

## CUPTOARE CU CONVECTIE MILLENNIAL BLACK MASK GASTRO PENTRU GASTRONOMIE

TAVI  
GN 1/1



SISTEM DE  
SPALARE INCLUS



### Electric

	5x GN 1/1	7x GN 1/1	11x GN 1/1	20x carucior - GN 1/1
cod	MKF511BM	MKF711BM	MKF1111BM	MKF2011BM
distanța între tavi	68 mm	68 mm	68 mm	66 mm
dimensiuni	730×784×(H)700 mm	730×784×(H)850 mm	730×785×(H)1130 mm	930×971×(H)1900 mm
<b>ventilatoare cu reverse</b>	1	2	2	4
putere/alimentare	7,8 kW/400 V	10,4 kW/400 V	15,4 kW/400 V	31 kW/400 V
greutate	78,4 kg	96 kg	113,8 kg	247,2 kg
lei	<b>13999,00</b>	<b>14999,00</b>	<b>19599,00</b>	<b>44399,00</b>
<b>SUPPORT</b>				<b>CARUCIOR</b>
cod	229521	229521	220795 <b>NOU</b>	EKCR20TC
dimensiuni	610×560×(H)770 mm	610×560×(H)770 mm	610×560×(H)620 mm	660×560×(H)1704 mm
tip	suport pentru 5 containere GN 1/1	suport pentru 5 containere GN 1/1	suport pentru 5 containere GN 1/1	suport pentru 20 containere GN 1/1
lei	<b>1699,00</b>	<b>1699,00</b>	<b>1749,00</b>	<b>10899,00</b>

TAVI  
GN 1/1



### Gaz

	5x GN 1/1	7x GN 1/1	11x GN 1/1	20x carucior - GN 1/1
cod	MKF511GBM	MKF711GBM	MKF1111GBM	MKF2011GBM
distanța între tavi	68 mm	68 mm	68 mm	66 mm
dimensiuni	730×849×(H)801 mm	730×849×(H)951 mm	730×849×(H)1231 mm	930×971×(H)1900 mm
<b>ventilatoare cu reverse</b>	1	2	3	4
putere gaz	9,3 kW	13,5 kW	17,5 kW	30 kW
putere/alimentare	300 W/230 V	500 W/230 V	700 W/230 V	1450 W/230 V
greutate	89 kg	108,5 kg	141 kg	247,2 kg
lei	<b>25799,00</b>	<b>29399,00</b>	<b>36099,00</b>	<b>66149,00</b>
<b>SUPPORT</b>				<b>CARUCIOR</b>
cod	229521	229521	220795 <b>NOU</b>	EKCR20TC
dimensiuni	610×560×(H)770 mm	610×560×(H)770 mm	610×560×(H)620 mm	660×560×(H)1704 mm
tip	suport pentru 5 containere GN 1/1	suport pentru 5 containere GN 1/1	suport pentru 5 containere GN 1/1	suport pentru 20 containere GN 1/1
lei	<b>1699,00</b>	<b>1699,00</b>	<b>1749,00</b>	<b>10899,00</b>

## CUPTOARE CU CONVECTIE MILLENNIAL BLACK MASK BAKERY PENTRU COFETARIE SI PANIFICATIE

TAVI

600x400



### Electric



4x

600x400

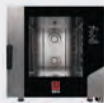

6x

600x400



10x

600x400



16x

carucior - 600x400

cod	MKF464BM	MKF664BM	MKF1064BM	MKF1664BM
distanța între tavi	80 mm	80 mm	80 mm	80 mm
dimensiuni	850x970x(H)700 mm	850x970x(H)850 mm	850x970x(H)1130 mm	930x977x(H)1900 mm
<b>ventilatoare cu reverse</b>	1	2	3	4
putere/alimentare	7,8 kW/400 V	10,4 kW/400 V	15,5 kW/400 V	31 kW/400 V
greutate	92,4 kg	108,2 kg	140,4 kg	247,2 kg
lei	<b>14749,00</b>	<b>16349,00</b>	<b>22549,00</b>	<b>43999,00</b>
<b>SUPPORT</b>				<b>CARUCIOR</b>
cod	229538	229538	220894 <b>NOU</b>	EKCR16TC
dimensiuni	710x640x(H)770 mm	710x640x(H)770 mm	710x640x(H)620 mm	740x560x(H)1704 mm
tip	suport pentru 5 tavi 600x400 mm	suport pentru 5 tavi 600x400 mm	suport pentru 5 tavi 600x400 mm	suport pentru 20 tavi 600x400 mm
lei	<b>1749,00</b>	<b>1749,00</b>	<b>1799,00</b>	<b>10099,00</b>

TAVI

600x400



### Gaz



4x

600x400



6x

600x400



10x

600x400



16x

carucior - 600x400

cod	MKF464GBM	MKF664GBM	MKF1064GBM	MKF1664GBM
distanța între tavi	80 mm	80 mm	80 mm	80 mm
dimensiuni	850x1035x(H)801 mm	850x1035x(H)951 mm	850x1035x(H)1231 mm	930x1160x(H)2060 mm
<b>ventilatoare cu reverse</b>	1	2	3	4
putere gaz	9,3 kW	13,5 kW	18 kW	30 kW
putere/alimentare	300 W/230 V	500 W/230 V	700 W/230 V	1450 W/230 V
greutate	102 kg	123 kg	158 kg	277,2 kg
lei	<b>22549,00</b>	<b>26249,00</b>	<b>33049,00</b>	<b>61399,00</b>
<b>SUPPORT</b>				<b>CARUCIOR</b>
cod	229538	229538	220894 <b>NOU</b>	EKCR16TC
dimensiuni	710x640x(H)770 mm	710x640x(H)770 mm	710x640x(H)620 mm	740x560x(H)1704 mm
tip	suport pentru 5 tavi 600x400 mm	suport pentru 5 tavi 600x400 mm	suport pentru 5 tavi 600x400 mm	suport pentru 20 tavi 600x400 mm
lei	<b>1749,00</b>	<b>1749,00</b>	<b>1799,00</b>	<b>10099,00</b>

## CUPTOARE CU CONVECTIE MILLENNIAL TOUCH SCREEN GASTRO PENTRU GASTRONOMIE SI MILLENNIAL TOUCH SCREEN BAKERY PENTRU COFETARIE SI PANIFICATIE, TOUCHSCREEN COLOR, ELECTRIC SI GAZ



### PANOU DE CONTROL TACTILE ELECTRONIC DE 7" PULL COLOR TFT

– Controlul electronic permite setarea foarte precisa a parametrilor necesari de gatit. Utilizatorul poate salva NOU si poate actualiza retelele vechi. Meniul de control este disponibil in pana la 42 de limbi, inclusiv poloneza si engleza.

- O serie de cuptoare moderne cu abur cu convecție Millennium Touch Screen.
- Echipat cu un panou electronic de control TFT color de 7", care permite setarea foarte precisa a parametrilor necesari de gatit. Utilizatorul poate salva rețete noi și poate actualiza rețetele vechi.
- Ambele serii au cuptoare în 4 dimensiuni. Aceasta gama largă va permite să alegeți un cuptor ideal pentru a pregăti de la 72 la 480 de mese pe zi.
- Cuptoarele din fiecare grupă sunt disponibile în versiuni electrice și pe gaz.

**GATIREA MULTILEVEL:** Aceasta functie permite pregătirea simultană a diferitelor feluri de mâncare care necesită aceleași condiții, dar timpi diferiți de gătire. Procesul poate fi pornit în același timp. Cuptorul indică când vasul trebuie scos din camera de gătire.

**SONDA MULTI-PUNCT:** O sonda multipunct cu 3 puncte de control al temperaturii pentru determinarea și măsurarea temperaturii din interiorul produsului gătire.

**SISTEM AUTOMAT DE SPALARE:** Fiecare cuptor vine standard cu 4 programe de spălare: ECO, NORMAL, INTENS, CLATIRE, adaptate la diferitele niveluri de murdărie ale camerei. Economii de apă de până la 30% cu capul de spălat NOU – nu numai că economisiți bani, dar contribuiți și la protejarea mediului.



**Airflowlogic™** – O soluție inovatoare constând într-o reproiectare completă a deflectorului. Efectul este o circulație îmbunătățită a aerului care asigură cele mai bune rezultate în gătire uniform pe fiecare nivel și în fiecare zonă a unui recipient GN sau al unei tavi de 600x400 mm. Airflowlogic™ garantează o calitate excelentă a procesării alimentelor în cuptor. Un cuptor Millennium cu brevet Airflowlogic™ oferă cea mai bună performanță în bucătărie.



**Humilogic™** – Nou sistem de umidificare care alimentează apa direct din ventilator. Oferă un nivel ridicat de umiditate și un consum mult mai mic de apă. În acest sistem, aburul ajunge până la capăt în alimentele gătite, ceea ce îi sporește gustul și aroma naturală. Humilogic™ este soluția pentru bucătari de top care se așteaptă la cele mai bune rezultate.



**Drylogic™** – Un sistem inovator de uscare pentru camera cuptorului. Prin verificarea constantă a parametrilor, cuptoarele Millennium TS au control deplin asupra menținerii nivelului corect de umiditate în camera de gătire. O supapă specială controlată de un computer controlează schimbul de aer în camera și elimină umiditatea excesivă.

### PANOU DE CONTROL TACTILE ELECTRONIC DE 7" (480x(H)800 mm)

**PULL COLOR TFT:** Controlul electronic permite setarea foarte precisă a parametrilor necesari de gatit. Utilizatorul poate salva NOU și poate actualiza rețetele vechi. Meniul de control este disponibil în până la 42 de limbi, inclusiv poloneza și engleza.

**PREINCALZIRE:** preincalzirea camerei de gatit la temperatura cu 30 de grade mai mare decat temperatura setata

**MENTINERE:** pastrarea alimentelor la o temperatura suficient de ridicata imediat dupa finalizarea ciclului de gatire

**RACIRE:** racirea rapida a camerei de gatit pentru a incepe un alt proces de gatit care necesita o temperatura mult mai scazuta

**HACCP:** posibilitatea de a descarca parametrii de functionare a cuptorului pentru a controla cursul corect al proceselor de gatit

**DOSPIRE:** cuptorul serveste drept camera de fermentare – o functie utila in versiunile de panificatie si cofetarie

**MENTINERE LA CALD:** cuptorul serveste ca un dulap de mentinere la cald, mentine temperatura corecta si nivelul corespunzator de umiditate al vaselor pana cand sunt servite.

Pornire intarziata a cuptorului cu pana la 24 de ore – o functie utila pentru a pregăti cuptorul sau vasul înainte ca personalul să vina la serviciu

O carte de bucate cu 500 de rețete

5 viteze ale ventilatorului, funcționare completă sau intermitentă



## Gatit DELTA T

Controlul nivelului de abur in 10 trepte

Reglarea temperaturii in intervalul 30°C-270°C pentru cuptoarele electrice si 30°C-260°C pentru cuptoarele pe gaz

Port USB pentru descarcare si incarcare rapida si usoara a retetelor de gatit si a datelor HACCP

Conexiune Wi-Fi pentru actualizari de software

Setarea temporizatorului

Possibilitatea de stocare a datei si orei curente

### ALTE CARACTERISTICI ALE CUPTOARELOR MILLENNIAL TOUCH SCREEN:

- Usa de siguranta - blocarea deschiderii la 60°, 90°, 120° si 180° previne arsurile operatorului din cauza miscarii necontrolate a usii dupa deschidere
- Usa camerei cu geam dublu si iluminarea LED faciliteaza observarea proceselor din cuptor
- Sticla exterioara racita prin gravitatie pentru o siguranta sporita a personalului
- Usa cu balama dreapta. Este posibil sa comandati cuptorul cu balama din stanga - optiune contra cost. Optiune disponibila numai din fabrica. Nu este posibila nicio modificare ulterioara a usii.

- Garnitura de usa din silicon gros si rezistent la caldura, montata in carcasa cuptorului, usor de inlocuit fara a apela la service
- Carcasa izolata a cuptorului nu numai ca economiseste energie electrica, dar maresc si siguranta personalului din bucatarie
- O cuva sub usa impiedica scurgerea aburului condensat, in special in ciclul mixt si abur. O podea uscata sub si in fata cuptorului garanteaza conditii de lucru sigure pentru personal
- Camera cuptorului realizata din otel inoxidabil AISI 304 de inalta calitate
- Camera de gatit cu colturi rotunjite pentru curatarea usoara a cuptorului
- Corp din otel inoxidabil
- Grad de protectie la apa: IPX4 - versiuni electrice si IPX3 - versiuni gaz
- Picioarele reglabile asigura o nivelare perfecta a cuptorului, cu efecte directe asupra functionarii acestuia
- Este necesar racordarea la curent electric, apa tratata, canalizare

### Cuptoare cu gaz:

- adaptat din fabrica pentru gaze naturale
- prevazut cu duze suplimentare pentru propan-butan
- racord gaz: 1/2"



## CUPTOARE CU CONVECTIE MILLENNIAL TOUCH SCREEN GASTRO PENTRU GASTRONOMIE

TAVI  
GN 1/1



SISTEM DE SPALARE INCLUS



### Electric



5x  
GN 1/1



7x  
GN 1/1



11x  
GN 1/1



20x

carucior - GN 1/1

cod	MKF511TS	MKF711TS	MKF1111TS	MKF2011TS
distanța între tavi	68 mm	68 mm	68 mm	66 mm
dimensiuni	730×784×(H)700 mm	730×784×(H)850 mm	730×785×(H)1130 mm	930×970×(H)1900 mm
ventilatoare cu reverse	1	2	2	4
putere/alimentare	7,8 kW/400 V	11,4 kW/400 V	15,4 kW/400 V	31 kW/400 V
greutate	78,4 kg	96 kg	113,8 kg	247,2 kg
lei	17149,00	18599,00	24699,00	51849,00
<b>SUPPORT</b>				<b>CARUCIOR</b>
cod	229521	229521	220795 <b>NOU</b>	EKCR20TC
dimensiuni	610×560×(H)770 mm	610×560×(H)770 mm	610×560×(H)620 mm	660×560×(H)1704 mm
tip	suporturi pentru 5 containere GN 1/1	suporturi pentru 5 containere GN 1/1	suporturi pentru 5 containere GN 1/1	suporturi pentru 20 containere GN 1/1
lei	1699,00	1699,00	1749,00	10899,00

TAVI  
GN 1/1



SISTEM DE SPALARE INCLUS



### Gaz



5x  
GN 1/1



7x  
GN 1/1



11x  
GN 1/1



20x

carucior - GN 1/1

cod	MKF511GTS	MKF711GTS	MKF1111GTS	MKF2011GTS
distanța între tavi	68 mm	68 mm	68 mm	66 mm
dimensiuni	730×850×(H)800 mm	730×850×(H)950 mm	730×850×(H)1230 mm	930×1162×(H)1954 mm
ventilatoare cu reverse	1	2	3	4
putere gaz	9,3 kW	13,5 kW	17,5 kW	30 kW
putere/alimentare	300 W/230 V	500 W/230 V	700 W/230 V	1450 W/230 V
greutate	89 kg	108,5 kg	141 kg	277 kg
lei	28849,00	32999,00	39799,00	73399,00
<b>SUPPORT</b>				<b>CARUCIOR</b>
cod	229521	229521	220795 <b>NOU</b>	EKCR20TC
dimensiuni	610×560×(H)770 mm	610×560×(H)770 mm	610×560×(H)620 mm	660×560×(H)1704 mm
tip	suporturi pentru 5 containere GN 1/1	suporturi pentru 5 containere GN 1/1	suporturi pentru 5 containere GN 1/1	suporturi pentru 20 containere GN 1/1
lei	1699,00	1699,00	1749,00	10899,00

## CUPTOARE CU CONVECTIE MILLENNIAL TOUCH SCREEN BAKERY PENTRU COFETARIE SI PANIFICATIE

TAVI

600x400



SISTEM DE  
SPALARE INCLUS



4x

600x400



6x

600x400



10x

600x400



16x

carucior - 600x400



Electric

cod	MKF464TS	MKF664TS	MKF1064TS	MKF1664TS
distanța între tavi	80 mm	80 mm	80 mm	80 mm
dimensiuni	850x970x(H)700 mm	850x970x(H)850 mm	850x970x(H)1130 mm	930x970x(H)1900 mm
ventilatoare cu reverse	1	2	3	4
putere/alimentare	7,8 kW/400 V	10,4 kW/400 V	17 kW/400 V	31 kW/400 V
greutate	92,4 kg	108,2 kg	140,4 kg	247,2 kg
lei	21349,00	24049,00	27299,00	53549,00
SUPPORT				CARUCIOR
cod	229538	229538	220894 <b>NOU</b>	EKCR16TC
dimensiuni	710x640x(H)770 mm	710x640x(H)770 mm	710x640x(H)620 mm	740x560x(H)1704 mm
tip	suporturi pentru 5 tavi 600x400 mm	suporturi pentru 5 tavi 600x400 mm	suporturi pentru 5 tavi 600x400 mm	suporturi pentru 20 tavi 600x400 mm
lei	1749,00	1749,00	1799,00	10099,00

TAVI

600x400



SISTEM DE  
SPALARE INCLUS



4x

600x400



6x

600x400



10x

600x400



16x

carucior - 600x400



Gas

cod	MKF464GTS	MKF664GTS	MKF1064GTS	MKF1664GTS
distanța între tavi	80 mm	80 mm	80 mm	80 mm
dimensiuni	850x1035x(H)800 mm	850x1035x(H)950 mm	850x1035x(H)1230 mm	930x1160x(H)2060 mm
ventilatoare cu reverse	1	2	3	4
putere gaz	9,3 kW	13,5 kW	18 kW	30 kW
putere/alimentare	300 W/230 V	500 W/230 V	700 W/230 V	1450 W/230 V
greutate	102 kg	123 kg	158 kg	277,2 kg
lei	29399,00	32999,00	39799,00	74999,00
SUPPORT				CARUCIOR
cod	229538	229538	220894 <b>NOU</b>	EKCR16TC
dimensiuni	710x640x(H)770 mm	710x640x(H)770 mm	710x640x(H)620 mm	740x560x(H)1704 mm
tip	suporturi pentru 5 tavi 600x400 mm	suporturi pentru 5 tavi 600x400 mm	suporturi pentru 5 tavi 600x400 mm	suporturi pentru 20 tavi 600x400 mm
lei	1749,00	1749,00	1799,00	10099,00



## CUPTOR CU ABURI PRIN CONVECTIE CU CAZAN MILLENNIAL TOUCH SCREEN GASTRO GN 1/1, ELECTRIC, CU SISTEM DE CURATARE AUTOMAT



### PANOU DE CONTROL TACTILE ELECTRONIC DE 7" PULL COLOR TFT

- Controlul electronic permite setarea foarte precisa a parametrilor necesari de gatit. Utilizatorul poate salva NOU si poate actualiza rețetele vechi. Meniul de control este disponibil in pana la 42 de limbi, inclusiv poloneza si engleza.

- Carcasa si camera sunt fabricate din otel inoxidabil AISI 304; camera in relief cu colturi rotunjite pentru o curatare usoara curatare.
- Usa vitrata, 2 straturi, ventilata prin gravitatie, balamale pe partea dreapta, cu dispozitiv de blocare la deschiderea la 60°, 90°, 120°, 120°, 180° pentru siguranta la locul de munca; posibilitatea de a comanda cuptorului cu balamale pe partea opusa.
- Tava de picurare pentru condens cu scurgere in usa.
- 2 ventilatoare cu inversare automata, cu 3 viteze.
- Generarea aburului intr-un boiler eficient - acces la un cantitati nelimitate de abur.
- Panou de control tactil TFT (Thin Film Transistor) - ecran tactil color cu o rezolutie de 800x480 mm.
- Sonda de puncte multiple - 3 puncte de masurare temperatura.
- Picioare reglabile pentru o nivelare perfecta.
- Gatire/coacere in 3 moduri: convecție, abur, combi.
- Posibilitatea de a controla hota de condensare si camera de gatit cu ajutorul panoului de control al cuptorului.
- Sistem de curatare automata cu 4 programe: eco, normal, intensiv, clatire.



**Airflowlogic™** - O solutie inovatoare constand intr-o reprojectare completa a deflectorului. Efectul este o circulatie imbunatatita a aerului care asigura cele mai bune rezultate in gatit uniform pe fiecare nivel si in fiecare zona a unui recipient GN. Airflowlogic™ garanteaza o calitate excelenta a procesarii alimentelor in cuptoare. Un cuptor Millennium cu brevet Airflowlogic™ ofera cea mai buna performanta in bucatarie.



**Drylogic™** - Un sistem inovator de uscare pentru camera cuptorului. Prin verificarea constanta a parametrilor, cuptoarele Millennium TS au control deplin asupra mentinerii nivelului corect de umiditate in camera de gatit. O supapa speciala controlata de un computer controleaza schimbul de aer in camera si elimina umiditatea excesiva.

### Functii suplimentare:

- **Preincalzire:** preincalzirea camerei cu +30°C mai mult decat temperatura setata,
- **Multilevel:** posibilitatea de a gati diferite alimente sub aceeasi conditii, cu timpi de gatire diferiti,
- **Mentineră la cald:** pastrarea mancarurilor gatite la temperatura de servire,
- **Cool Down:** racirea rapida a camerei de gatit pentru o schimbare rapida produsului care este gatit in acel moment,
- **Dospitor:** cuptorul actioneaza ca o camera de dospire.
- Echilat cu port USB - pentru descarcarea datelor HACCP.
- Conexiune Wi-Fi pentru actualizari de software.
- Programabil: memorare a 500 de programe, pana la 10 trepte. in fiecare.
- Posibilitatea de a selecta rețetele preferate si de a le seta ca rețete de pornire rapida.
- Meniu in 42 de limbi.
- Programarea pornirii intarziata pentru pana la 24 de ore.
- Protectie impotriva supraincalzirii.
- Putere de incalzire mai mare in comparatie cu MKF711TS (15 kW) sau MKF11111VTS (19 kW) va permite sa profitati la maximum de intreaga capacitate a boilerului.
- Capacitatea camerei: 7 tavi GN 1/1 (MKF711VTS) sau 11 tavi GN 1/1 (MKF11111VTS) - nu sunt incluse.
- Factor de etansare: IPX 5.
- Interval de temperatura: 30°C pana la 270 °C.
- Distanța dintre lamele: 73 mm.



TAVI  
GN 1/1



SISTEM DE  
SPALARE INCLUS



MKF711VTS



MKF1111VTS



**Electric**

	7x GN 1/1	11x GN 1/1
cod	MKF711VTS cu boiler	MKF1111VTS cu boiler
distanța între tavii	68 mm	68 mm
dimensiuni	730×784×(H)850 mm	730×785×(H)1130 mm
<b>ventilatoare cu reverse</b>	2	2
putere/alimentare	15 kW/400 V	19 kW/400 V
greutate	96 kg	113,8 kg
lei	<b>26999,00</b>	<b>34349,00</b>
<b>SUPORT</b>		
cod	229521	220795 <b>NOU</b>
dimensiuni	610×560×(H)770 mm	610×560×(H)620 mm
tip	suporturi pentru 5 containere GN 1/1	suporturi pentru 5 containere GN 1/1
lei	<b>1699,00</b>	<b>1749,00</b>

**BOILER** - datorită generării de abur într-un boiler eficient, aveți acces la o cantitate nelimitată de abur. Datorită acestuia alimentele dvs. vor fi pregătite în mod optim, astfel încât să reducă la minimum riscul de risipă și să asigurați o repetabilitate perfectă a preparatelor dvs. Legume la aburi, pește, carne - veți pregăti totul rapid, fără complicații și cu toate valorile nutritive păstrate.

## CUPTOR CONVECTIE CU ABUR MILLENNIAL, BLACK MASK GASTRO COMPACT, ELECTRIC, CONTROLAT ELECTRONIC



**SUPER  
COMPACT**  
DOAR 50 CM



**Airflowlogic™** - O solutie inovatoare constand intr-o reproiectare completa a deflectorului. Efectul este o circulatie imbunatatita a aerului care asigura cele mai bune rezultate in gatit uniform pe fiecare nivel si in fiecare zona a unui recipient GN. Airflowlogic™ garanteaza o calitate excelenta a procesarii alimentelor in cuptoare. Un cuptor Millennial cu brevet Airflowlogic™ ofera cea mai buna performanta in bucatarie.



**Humilogic™** - Nou sistem de umidificare care alimenteaza apa direct din ventilator. Oferă un nivel ridicat de umiditate si un consum mult mai mic de apa. In acest sistem, aburul ajunge pana la capat in alimentele gatite, ceea ce ii sporeste gustul si aroma naturala. Humilogic™ este solutia pentru bucatari de top care se asteapta la cele mai bune rezultate.

- MILLENNIAL BLACK MASK COMPACT o gama noua de cuptoare cu convecție cu umidificator. Latimea de doar 500 mm a cuptorului il transforma in alegerea perfecta pentru bucataria ta, se va potrivi chiar in cel mai mic spatiu din bucatarie.
- Panoul de control are un design deosebit, atunci cand cuptorul este pus in functiune panoul se activeaza.
- Panoul electronic de control tactil de 7" permite setarea usoara si precisa a parametrilor de gatit presetati.

### CELE MAI IMPORTANTE CARACTERISTICI:

- **Sonda** - Datorita sondei, cuptorul poate controla si mentine constant indicatiile de temperatura. Corecteaza constant si automat parametrii, asigurand rezultate perfecte la coacere si gatire.
- **Sistem automat de spalare** - montat din fabrica. 4 programe de spalare: Eco, Normal, intensiv, clatit. Adaptat la diferite niveluri murdarii din camera. Noul design al sistemului de spalare economiseste pana la 30% consumul de energie.
- **Preincalzire** - Incalzirea camerei cuptorului cu + 30 ° C mai mult decat temperatura setata pentru a pregati cuptorul pentru o preparare.
- **Pastrarea** alimentelor la o temperatura suficient de ridicata, imediat dupa sfarsitul ciclului de gatit
- **Racire** - Scaderea rapida a temperaturii in camera pentru a se adapta la nevoile urmatoarelor preparate care necesita o temperatura mai mica decat temperatura din camera.
- **HACCP** - Capacitatea de a citi parametrii de functionare ai cuptorului pentru a controla cursul corect al procesului de gatire.
- **Dospitor** - Functia transforma cuptorul intr-un dospitor profesional.
- **Mentintre la cald** - Cuptorul mentine preparatele gata de servire la o temperatura suficient de ridicata si pana cand sunt servite.
- 100 de programe pot fi salvate in 10 pasi fiecare.
- Alegeti unul dintre cele 100 de programe si apasati START. Cuptorul va incepe sa functioneze pastrand cu precizie inregistrarea parametrilor precum temperatura camerei, temperatura interioara timpul de gatit, gradul de umiditate in fiecare pas. Acesti parametri pot fi modificati, salvati sau stersi din memorie.
- Trei viteze de ventilator de la 1.500 la 2.800 rpm Controlul vitezei ventilatorului in trei trepte asigura personalizarea fluxului de aer pentru gatit si temperatura omogena in toata camera.
- **Gatit cu sonda** - Datorita sondei, cuptorul poate controla si mentine constant indicatiile de temperatura. Corecteaza



### Panoul de control tactil negru de 7"

- controlul electronic permite setarea foarte precisa a parametrilor necesari de gatit.

Toti parametrii si functiile sunt indicati fie numeric, fie prin pictograme.



**SISTEM DE SPALARE INCLUS**



**6x**  
GN 2/3



**6x**  
GN 1/1



**10x**  
GN 1/1

cod	MKF623CBM	MKF611CBM	MKF1011CBM
productivitate	54-72 portii/zi	90-120 portii/zi	150-200 portii/zi
distanța între tavi	68 mm	68 mm	68 mm
dimensiuni	500x750x(H)700 mm	500x930x(H)700 mm	500x930x(H)970 mm
ventilatoare cu reverse	1	1	1
putere/alimentare	5,2 kW/400 V	7,8 kW/400 V	15,4 kW/400 V
greutate	61,6 kg	70,8 kg	95,2 kg
lei	<b>14099,00</b>	<b>17049,00</b>	<b>21899,00</b>
<b>SUPORT</b>			
cod	MKTS623C	MKTS11C	MKTS11C
dimensiuni	500x556x(H)770 mm	500x736x(H)770 mm	500x736x(H)770 mm
lei	<b>3189,00</b>	<b>3189,00</b>	<b>3189,00</b>

constant și automat parametrii, asigurând rezultate perfecte la coacere și gătire.

- **Gătit cu funcția Delta T.** Aceasta este o metoda imbunatatita de gatit cu sonda. Este deosebit de util pentru gatit bucati mai mari de carne. Sistemul mentine automat o usoara diferenta între temperatura din camera și cea a alimentelor. Ca urmare, mancarea este gatita uniform.
- **Port USB.** Soluția este recomandata în special pentru bucatariile cu lant. Programeaza un singur cuptor. Celelalte pot fi încarcate cu acelasi program prin portul USB.

### ALTE CARACTERISTICI ALE CUPTOARELOR MILLENNIAL

#### BLACK MASK:

- Reglarea temperaturii în intervalul 30-270 ° C. Setarea timpului de lucru până la 11 h, 59 min sau funcționare continuă NON-STOP.
- Întârzierea pornirii automate a cuptorului până la 24 de ore. Opțiunea de a salva ziua și ora curentă. Alarma declansata de hota de condens.
- Aburul generat prin pulverizarea directă a apei pe încălzitoare, cu reglare a nivelului de abur pe 10 nivele. Usa de camera cu geam termopan și iluminare cu LED. Usa sigura - deschidere încuietori la 60 °, 90 °, 120 ° și 180 ° previne arderile

operatorului din cauza miscării necontrolate a usii după deschiderea lor.

- Sticla exterioară a cuptorului este racită de gravitate.
- Usa cu balama în dreapta.
- Deschiderea ușoară a geamului usii interioare.
- Etansare usă din grosime și rezistență ridicată temperatura silicului. Usor de întocuit.
- Carcasa izolată a cuptorului nu numai că economisește consumul de electricitate, dar crește siguranța personalului din bucătărie.
- Camera cuptorului este fabricată din oțel inoxidabil AISI 304 de înaltă clasă.
- Carcasa completă din oțel inoxidabil.
- Etanșeitate: IPX 4.
- Picioarele reglabile.



## CUPTOR CONVECTIE CU ABUR, MILLENNIAL TOUCH SCREEN GASTRO COMPACT, CU UN SISTEM DE CURATARE, ELECTRIC, CONTROLAT ELECTRONIC

→ | 50 cm | ←



**Airflowlogic™** - O solutie inovatoare constand intr-o reprojectare completa a deflecteurului. Efectul este o circulatie imbanatata a aerului care asigura cele mai bune rezultate in gatit uniform pe fiecare nivel si in fiecare zona a unui recipient GN sau al unei tavi de 600x400 mm. Airflowlogic™ garanteaza o calitate excelenta a procesarii alimentelor in cuptoare. Un cuptor Millennial cu brevet Airflowlogic™ ofera cea mai buna performanta in bucatarie.



**Humilogic™** - Nou sistem de umidificare care alimenteaza apa direct din ventilator. Ofera un nivel ridicat de umiditate si un consum mult mai mic de apa. In acest sistem, aburul ajunge pana la capat in alimentele gatite, ceea ce ii sporeste gustul si aroma naturala. Humilogic™ este solutia pentru bucatari de top care se asteapta la cele mai bune rezultate.



**Drylogic™** - Un sistem inovator de uscare pentru camera cuptorului. Prin verificarea constanta a parametrilor, cuptoarele Millennial TS au control deplin asupra mentinerii nivelului corect de umiditate in camera de gatit. O supapa speciala controlata de un computer controleaza schimbul de aer in camera si elimina umiditatea excesiva.

- MILLENNIAL BLACK MASK COMPACT o gama noua de cuptoare cu convecție cu umidificator. Latimea de doar 500 mm a cuptorului il transforma in alegerea perfecta pentru bucataria ta, se va potrivi chiar in cel mai mic spatiu din bucatarie.
- Panul de control are un design deosebit, atunci cand cuptorul este pus in functiune panoul se activeaza.
- Panoul electronic de control tactil de 7 inch permite setarea usoara si precisa a parametrilor de gatit presetati.
- Panul de control are un design deosebit, atunci cand cuptorul este pus in functiune panoul se activeaza.
- Panoul electronic de control tactil de 7 inch permite setarea comoda si precisa a parametrilor de gatit presetati.

### CELE MAI IMPORTANTE CARACTERISTICI:

- **Sonda** - Datorita sondei, cuptorul poate controla si mentine constant indicatiile de temperatura. Corecteaza constant si automat parametrii, asigurand rezultate perfecte la coacere si gatire.
- **Sistem automat de spalare** - montat din fabrica. 4 programe de spalare: Eco, Normal, intensiv, clatit. Adaptat la diferite niveluri murdare din camera. Noul design al sistemului de spalare economiseste pana la 30% consumul de energie.
- **Preincalzire** - Incalzirea camerei cuptorului cu + 30 ° C mai mult decat temperatura setata pentru a pregati cuptorul pentru

o preparare.

- Pastrarea alimentelor la o temperatura suficient de ridicata, imediat dupa sfarsitul ciclului de gatit
- **Racire** - Scaderea rapida a temperaturii in camera pentru a se adapta la nevoile urmatoarelor preparate care necesita o temperatura mai mica decat temperatura din camera.
- **HACCP** - Capacitatea de a citi parametrii de functionare ai cuptorului pentru a controla cursul corect al procesului de gatire.
- **Dospitor** - Functia transforma cuptorul intr-un dospitor profesional.
- **Mentinere la cald** - Cuptorul mentine preparatele gata de servire la o temperatura suficient de ridicata si pana cand sunt servite.
- **100 de programe pot fi salvate in 10 pasi fiecare.** Alegeți unul dintre cele 100 de programe si apasati START. Cuptorul va incepe el insusi sa functioneze pastrand cu precizie inregistrarea parametrilor precum temperatura camerei, temperatura interioara timpul de gatit, gradul de umiditate in fiecare pas. Acesti parametri pot fi modificati, salvati sau stersi din memorie.
- **Trei viteze de ventilator de la 1.500 la 2.800 rpm.** Controlul vitezei ventilatorului in trei trepte asigura personalizarea fluxului de aer pentru gatit si temperatura omogena in toata camera.
- **Gatire cu sonda** - Datorita sondei, cuptorul poate controla si mentine constant indicatiile de temperatura. Corecteaza



**SISTEM DE SPALARE INCLUS**

### PANOU DE CONTROL TACTILE ELECTRONIC DE 7" PULL COLOR TFT

– Controlul electronic permite setarea foarte precisa a parametrilor necesari de gatit. Utilizatorul poate salva NOU si poate actualiza rețetele vechi. Meniul de control este disponibil in pana la 42 de limbi, inclusiv poloneza si engleza.

**SUPER COMPACT**  
DOAR 50 CM



**6x**  
GN 2/3



**6x**  
GN 1/1



**10x**  
GN 1/1

cod	MKF623CTS	MKF611CTS	MKF1011CTS
productivitate	54-72 portii/zi	90-120 portii/zi	150-200 portii/zi
distanța între tavi	68 mm	68 mm	68 mm
dimensiuni	500x750x(H)700 mm	500x930x(H)700 mm	500x930x(H)970 mm
ventilatoare cu reverse	1	1	1
putere/alimentare	5,2 kW/400 V	7,8 kW/400 V	15,4 kW/400 V
greutate	61,6 kg	70,8 kg	95,2 kg
lei	<b>17949,00</b>	<b>20449,00</b>	<b>25949,00</b>
<b>SUPORT</b>			
cod	MKTS623C	MKTS11C	MKTS11C
dimensiuni	500x556x(H)770 mm	500x736x(H)770 mm	500x736x(H)770 mm
lei	<b>3189,00</b>	<b>3189,00</b>	<b>3189,00</b>

constant și automat parametrii, asigurând rezultate perfecte la coacere și gătire.

- **Gătire cu funcția Delta T.** Aceasta este o metodă îmbunătățită de gătire cu sonda. Este deosebit de util pentru gătirea bucăților mari de carne. Sistemul menține automat o ușoară diferență între temperatura din camera și cea a alimentelor. Ca urmare, mâncarea este gătită uniform.
- **Port USB.** Soluția este recomandată în special pentru bucatăriile cu lanternă. Programează un singur cuptor. Celelalte pot fi încărcate cu același program prin portul USB.

### ALTE CARACTERISTICI ALE CUPTOARELOR MILLENNIAL BLACK MASK:

- Reglarea temperaturii în intervalul 30-270 ° C. Setarea timpului de lucru până la 11 h, 59 min sau funcționare continuă NON-STOP.
- Întârzierea pornirii automate a cuptorului până la 24 de ore. Opțiunea de a salva ziua și ora curentă. Alarma declansată de hota de condens.
- Aburul generat prin pulverizarea directă a apei pe încălzitoare, cu reglare a nivelului de abur pe 10 nivele. Usa de camera cu geam termopan și iluminare cu LED.
- Usa sigură - deschidere încuietori la 60 °, 90 °, 120 ° și 180 °

previne arderile operatorului din cauza mișcării necontrolate a usii după deschiderea lor.

- Sticla exterioară a cuptorului este răcită de gravitație.
- Usa cu balamă în dreapta.
- Deschiderea ușoară a geamului usii interioare.
- Etansare usa din grosime și rezistență ridicată la temperatura silicónului.
- Usor de înlocuit.
- Carcasa izolată a cuptorului nu numai că economisește consumul de electricitate, dar crește siguranța personalului din bucatărie.
- Camera cuptorului este fabricată din oțel inoxidabil AISI 304 de înaltă clasă.
- Carcasa completă din oțel inoxidabil.
- Etanșate: IPX 4.
- Picioare reglabile.



## DUS MANUAL, UNIVERSAL, PENTRU CURATAREA CAMEREI DE CUPTOR

- Ideal pentru orice bucatar-sef pentru a mentine aparatele de gatit curate.
- Potrivit pentru curatarea oricaror camere de cuptor: conventionale, cuptoare combinate, cuptoare, camere de prajire, placi de taiat, mese de lucru precum si orice dispozitive sau componente care pot fi spalate cu jet de apa.
- Un furtun lung de 2 metri ajunge la orice dispozitiv din gama sa.
- Manerul ergonomic, cu o supapa de golire, este confortabil de tinut.
- Un suport dedicat care poate fi asezata pe carcasa cuptorului [conform indicatiilor tehnicianului] sau pe perete folosind 3 suruburi.
- Jetul este impartit intr-un numar mai mic, utilizand un filtru care maresc suprafata de curatat acoperita.
- Ideal pentru apa la o temperatura de la 5°C la 85°C.
- Debit maxim de apa pana la 11 l/m la o presiune de 3 bari.
- Presiunea recomandata a apei de alimentare: 3 bari.
- Presiunea de lucru a apei de alimentare: 0,5-7 bar.



810323

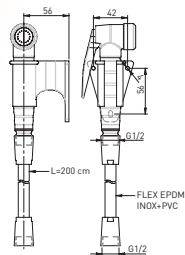

- PA66 carcasa din nylon, piese din otel acoperite cu crom rezistent la coroziune.
- Racord de supapa de alimentare cu apa: 1/2".

cod	mm	lei
810323	56x42x(H)2000	204,99

## DOSPITOR

- Se foloseste pentru a mentine preparatele gatite la o temperatura suficient de ridicata, pana la 85 °C.
- Temperatura controlata electronic.
- Functia PREINCALZIRE permite incalzirea rapida a camerei.
- Camera este fabricata din otel AISI 430 de cea mai buna calitate.
- Dispozitiv pe 4 roti, inclusiv 2 cu frana pentru siguranta.
- NOTA: sunt necesare elemente de conectare suplimentare pentru conectarea la abur - solicitati detalii



MKLM1064

	10x 600x400	12x GN 1/1	10x 600x400
cod	MKL1064S	MKM1211	MKLM1064
compatibil cu	cuptor Millennium Smart Bakery 4x 600x400 mm 6x 600x400 mm 10x 600x400 mm	cuptor Millennium Black Mask si Touch Screen 5x GN 1/1 7x GN 1/1 12x GN 1/1	cuptor Millennium Black Mask si Touch Screen 4x 600x400 mm 6x 600x400 mm 10x 600x400 mm
distaanta intre tavi	85 mm	75 mm	85 mm
dimensiuni	850x1030x(H)770 mm	730x875x(H)770 mm	850x1030x(H)770 mm
umidificare	indirect prin intermediul unui buton pe panoul de control	-	8-pasi reglare folosind panoul decontrol
temperatura dospire	25-65 °C	-	20-40 °C
temperatura PREINCALZIRE pentru dospire	-	-	20 °C
temperatura PREINCALZIRE pentru mentinere la cald	-	65 °C	65 °C
retentie de caldura	-	30-60 °C	30-60 °C
putere/alimentare	2,4 kW/230 V	1,8 kW/230 V	1,8 kW/230 V
greutate	91 kg	70,8 kg	91 kg
lei	9259,00	11149,00	11999,00

## CUPTOARE STATICE DE PANIFICATIE SI COFETARIE 600X400 MM CU ABUR, CONTROLATE ELECTRONIC, ELECTRICE

- O solutie ideala pentru unitatile gastronomice precum pizzerii, restaurante, cantine, brutarii sau bucatarii de restaurante, care iti doresc sa pregateasca pentru clientii lor produse de cofetarie, panificatie si pizza la cel mai inalt nivel cu o precizie ridicata in procesul de productie.
- Programabil - capacitatea de a salva 50 retete in memoria cuptorului.
- Camera in care se pot pune tavi de 600x400 [model MKF D1T] sau o capacitate de doua tavi de 600x400 dispuse pe o singura suprafata [model MKF D2T].
- Panou de control tactil usor de utilizat si intuitiv.
- Reglarea incalzitoarelor si termostatelor folosind butoane dedicate de pe panoul de control.
- Temporizator.
- Temperatura maxima: 350 °C.
- Sistemul de abur instalat face cuptorul potrivit chiar si pentru un numar foarte mare de tipuri sofisticate de coacere.
- Camera este realizata in intregime din otel inoxidabil AISI 430.
- Factor de etansare IPX3.

TAVI

600x400



1x  
600x400



2x  
600x400

cod	MKFD1T	MKFD2T
dimensiuni	850x980x(H)435 mm	850x1250x(H)435 mm
numarul de incalzitoare	6	6
putere/alimentare	2,7 kW/230 V	5,4 kW/400 V
greutate	65 kg	85 kg
lei	12799,00	14149,00



## HOTE CONDENSATOARE

- Motor monofazat cu un singur sens de rotatie.
- Debit maxim de aer: de la 400 m<sup>3</sup> / h la 600 m<sup>3</sup> / h.
- Carcasa este fabricata din otel AISI 430 de cea mai buna calitate.
- Conexiune la apa proaspata ¾" cu presiune 100-200 kPa (1,0-2,0 bar).
- Nu necesita conectarea la teava fixa sau cos de ventilare.
- Inclus:
  - furtun de racordare pentru apa cu filet de ¾", lungime de 1,5 m.
  - 1 filtru labirint.
  - cablu electric de 1,6 m.
  - teava canalizare Ø 30 mm.



cod		V	W	mm	greutate	lei
MKKC4S	Hota de condensare pentru cuptoare Millennial Smart cu 4 tavi	230	600	850x1045x(H)308	26	<b>5999,00</b>
MKKC4	Hota de condensare pentru cuptoare Millennial Touch Screen si Black Mask cu 4 tavi	230	600	850x1045x(H)308		<b>5999,00</b>
MKKC5S	Hota de condensare pentru cuptoare Millennial cu 5 tavi	230	600	730x860x(H)308		<b>5949,00</b>
MKKC5	Hota de condensare pentru cuptoare Millennial TS cu 5 rafturi	230	600	730x860x(H)308	26	<b>5949,00</b>
MKKC610S	Hota de condensare pentru cuptoare Millennial Smart cu 6 si 10 tavi	230	600	850x1045x(H)308		<b>5949,00</b>
MKKC610	Hota de condensare pentru cuptoare Millennial Touch Screen si Black Mask cu 6 si 10 tavi	230	600	850x1045x(H)308		<b>5949,00</b>
MKKC610C	Hota de condensare pentru cuptoare Millennial TS cu 6 si 10 tavi	230	600	500x942x(H)308	19	<b>5499,00</b>
MKKC623C	Hota de condensare pentru cuptoare Millennial Touch Screen si Black Mask cu 6 tavi	230	600	500x762x(H)308		<b>4859,00</b>
MKKC711S	MKKC711S Hota pentru cuptoare Millennial Smart cu 7 tavi	230	600	730x860x(H)308		<b>5949,00</b>
MKKC711	Hota de condensare pentru cuptoare Millennial TS cu 7 tavi	230	600	730x860x(H)308	26	<b>5949,00</b>
MKKC1620S	Hota pentru cuptoare Millennial cu 16 si 20 de tavi	230	600	930x1045x(H)308		<b>7809,00</b>
MKKC1620	Hota de condensare pentru cuptoare Millennial TS cu 16 si 20 de tavi	230	600	930x1045x(H)308	31,4	<b>7999,00</b>

## SET DE STIVUIRE PENTRU CUPTOR

- Un kit de asamblare necesar pentru conectarea sigura si placuta din punct de vedere estetic a stivelor de cuptor.
- Structura din otel inoxidabil AISI 430.
- Accesoriile necesare sunt incluse in kit.
- Kiturile sunt diferite, adaptate modelelor de cuptoare conectate.

cod	mm	lei
MKS11	(H)55	<b>2099,00</b>
MKS11C	(H)55	<b>2299,00</b>
MKS23C	(H)55	<b>2299,00</b>
MKS64	(H)55	<b>2299,00</b>

## SISTEM AUTOMAT DE SPALARE PENTRU CUPTOARELE MILLENNIAL BLACK MASK

- 4 programe de curatare: Eco, Normal, Intensiv, Clatire, adaptat la diferite niveluri de contaminare a camerei.
- Noul cap de curatare permite economii de apa de pana la 30%.

cod	lei
MKWT	<b>2349,00</b>

## SET DE INSTALARE PENTRU CUPTOARE MILLENNIALE

- Kitul include: un sifon special din PVC in forma de U, furtun de evacuare.
- Carcasa sifonului din otel inoxidabil mentine o distanta sigura intre soba si instalare si perete.

cod	lei
MKKPIC	<b>1389,00</b>
MKKPI	<b>1039,00</b>

## SONDA INTERNA DE TEMPERATURA CU MANER EKA

- Destinat masurarii temperaturii si monitorizarii in interiorul unui produs preparat termic.
- Coopereaza cu software-ul cuptorului pentru a mentine temperatura presetata. 1 punct.
- Pentru cuptoarele cu recipient GN si placi de 600 x 400 mm, gama Millennial Black Mask, numai ca echipament optional.

cod	lei
EKSCS	<b>1059,00</b>

## DISPOZITIV AFUMARE PENTRU CUPTOARE MILLENNIAL

- Destinat afumarii tuturor tipurilor de carne, legume si fructe, direct in camerele cuptoarelor cu abur si convecție din seria Millennial.
- Dispozitivul este fabricat din otel inoxidabil AISI 430 de inalta calitate Incalzit electric controlat electronic.
- Temperatura poate fi reglata in intervalul 20 °C - 80 °C.
- Varianta electrica, monofazata.
- Cablu de alimentare de 1,6 m lungime.
- Greutate neta: 2,6 kg.
- O gama larga de chipsuri aromatice din lemn disponibile in oferta HENDI.

cod	V	W	mm	lei
MKAF	230	200	173x432x(H)39	<b>1629,00</b>

## ACCESORII CUPTOARE MILLENNIAL

	cod	sistem automat de spalare	sonda temperatura	suport	hota	kit suprapunere	camera dospire/ mentinere la cald	
Electric	MKF511S	-	-	229521	MKKC5S	MKS11		
	MKF511BM	DA	DA	229521	MKKC5	MKS11	MKM1211	
	MKF511TS	DA	DA	229521	MKKC5	MKS11	MKM1211	
	MKF711S	-	-	229521	MKKC711S	MKS11		
	MKF711BM	DA	DA	229521	MKKC711	MKS11	MKM1211	
	MKF711TS	DA	DA	229521	MKKC711	MKS11	MKM1211	
	MKF1111S	-	-	220795	MKKC711S	MKS11		
	MKF1111BM	DA	DA	220795	MKKC711	MKS11	MKM1211	
	MKF1111TS	DA	DA	220795	MKKC711	MKS11	MKM1211	
	MKF2011S	-	-	EKCR20TC	MKKC1620S			
	MKF2011BM	DA	DA	EKCR20TC	MKKC1620			
	MKF2011TS	DA	DA	EKCR20TC	MKKC1620			
GASTRO	Electric/Compact	MKF623CBM	DA	DA	MKTS623C	MKKC623C	MKS23C	
		MKF623CTS	DA	DA	MKTS623C	MKKC623C	MKS23C	
		MKF611CBM	DA	DA	MKTS11C	MKKC610C	MKS11C	
		MKF611CTS	DA	DA	MKTS11C	MKKC610C	MKS11C	
		MKF1011CBM	DA	DA	MKTS11C	MKKC610C		
		MKF1011CTS	DA	DA	MKTS11C	MKKC610C		
Gaz	MKF511GS	-	-	229521	MKKC5S	MKS11		
	MKF511GBM	MKWT	EKSC / EKSCS	229521	MKKC5	MKS11	MKM1211	
	MKF511GTS	DA	DA	229521	MKKC5	MKS11	MKM1211	
	MKF711GS	-	-	229521	MKKC711S	MKS11		
	MKF711GBM	MKWT	EKSC / EKSCS	229521	MKKC711	MKS11	MKM1211	
	MKF711GTS	DA	DA	229521	MKKC711	MKS11	MKM1211	
	MKF1111GS	-	-	220795	MKKC711S	MKS11		
	MKF1111GBM	MKWT	EKSC / EKSCS	220795	MKKC711	MKS11	MKM1211	
	MKF1111GTS	DA	DA	220795	MKKC711	MKS11	MKM1211	
	MKF2011GBM	MKWT	EKSC / EKSCS	EKCR20TC	MKKC1620			
	MKF2011GTS	DA	DA	EKCR20TC	MKKC1620			
	BAKERY	Electric	MKF464S	-	-	229538	MKKC4S	MKS64
MKF464BM			MKWT	EKSC / EKSCS	229538	MKKC4	MKS64	MKLM1064
MKF464TS			DA	DA	229538	MKKC4	MKS64	MKLM1064
MKF664S			-	-	229538	MKKC610S	MKS64	MKL1064S
MKF664BM			MKWT	EKSC / EKSCS	229538	MKKC610	MKS64	MKLM1064
MKF664TS			DA	DA	229538	MKKC610	MKS64	MKLM1064
MKF1064S			-	-	220894	MKKC610S	MKS64	MKL1064S
MKF1064BM			MKWT	EKSC / EKSCS	220894	MKKC610	MKS64	MKLM1064
MKF1064TS			DA	DA	220894	MKKC610	MKS64	MKLM1064
Gaz		MKF1664S	-	-	EKCR16TC	MKKC1620S		
		MKF1664BM	MKWT	EKSC / EKSCS	EKCR16TC	MKKC1620		
		MKF1664TS	DA	DA	EKCR16TC	MKKC1620		
		MKF464GS	-	-	229538	MKKC4S	MKS64	MKL1064S
		MKF464GBM	MKWT	EKSC / EKSCS	229538	MKKC4	MKS64	MKLM1064
		MKF464GTS	DA	DA	229538	MKKC4	MKS64	MKLM1064
		MKF664GS	-	-	229538	MKKC610S	MKS64	MKL1064S
		MKF664GBM	MKWT	EKSC / EKSCS	229538	MKKC610	MKS64	MKLM1064
		MKF664GTS	DA	DA	229538	MKKC610	MKS64	MKLM1064
Electric / DECK OVEN	MKF1064GS	-	-	220894	MKKC610S	MKS64	MKL1064S	
	MKF1064GBM	MKWT	EKSC / EKSCS	220894	MKKC610	MKS64	MKLM1064	
	MKF1064GTS	DA	DA	220894	MKKC610	MKS64	MKLM1064	
	MKF1664GBM	MKWT	EKSC / EKSCS	EKCR16TC	MKKC1620			
	MKF1664GTS	DA	DA	EKCR16TC	MKKC1620			
	229491	-	-	MKTS64		MKS64	MKL1064S	
229507	-	-	MKTS64			MKL1064S		

## TAVI CONVECTOMAT CLASSIC®



**Margine de 20 mm** – permite plasarea tavii in vitrinele de vanzare – permite promovarea si vanzarea produselor „direct din tava”

**Strat anti lipire** – stratul cu efect de marmura previne lipirea; coacere cu 90% mai putina grasime

**Structura robusta** previne deformarea nedorita. Tava este positionata in siguranta in ghidajele camerei cuptorului si este rezistenta la deformare

**Material gros 1 mm** garanteaza stabilitatea temperaturii pe toata suprafata, fara distributie neuniforma a caldurii

**Siguranta** – nu se elibereaza toxine la coacerea alimentelor la temperaturi ridicate

**Fabricata din otel emailat inodor** – fara emisii de mirosuri la temperaturi ridicate. Rezistenta termica pana la 300°C



**Unghiuri drepte** care permit utilizarea maxima a produsului finit si estimarea mai usoara a costurilor alimentare, ceea ce se traduce in profit, permitand marimi exacte ale portiilor si o rentabilitate mai mare a investitiei



890356

890349

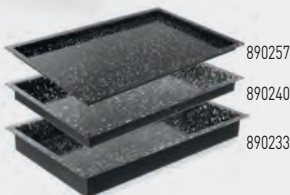

890257

890240

890233

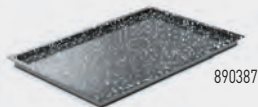

890387

### TAVA CONVECTOMAT CLASIC GN 2/3

cod	mm	lei
890356	345x325x(H)20	159,99
890349	345x325x(H)40	179,99

### TAVA CONVECTOMAT CLASIC GN 1/1

cod	mm	lei
890257	530x325x(H)20	179,99
890240	530x325x(H)40	189,99
890233	530x325x(H)60	199,99

### TAVA CONVECTOMAT CLASIC 600X400

cod	mm	lei
890387	600x400x(H)20	198,99



## TAVI DIN ALUMINIU GN1/1 CU INVELIS ANTIADERENT CONVECTOMAT

- Fabricat din aluminiu.
- Suprafata finisata cu strat de acoperire antiaderent din PTFE.
- Marime: GN 1/1.

- Adecvat pentru utilizarea in cuptor la temperatura maxima de 200°C.
- Nu poate fi spalat in masina de spalat vase.

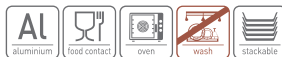

**NOU**



808825



808832

## PLACA GRATAR, GRILPLAT CONVECTOMAT CU NERVURI

- Fabricat din aluminiu turnat.
- Grosime: 9 mm.

cod	mm	lei
808825	530x325x(H)15	420,99

## GRATAR CONVECTOMAT GRILL

- 24 coaste, 9 mm grosime.
- Spatiu intre coaste: 13 mm.

cod	mm	lei
808832	530x325x(H)15	349,99



808849



808863

## TAVA PENTRU CUPTOR CU STRAT ANTIADERENT CONVECTOMAT ROAST

- Dimensiuni interioare: 470x260 mm.
- Margine usor plata, lata - previne varsarea uleiului.

cod	mm	lei
808849	530x325x(H)17	232,99

## TAVA DE COPT CU STRAT ANTIADERENT CONVECTOMAT BAKE

- Margine ingusta.
- Dimensiuni interioare: 505x300 mm.

cod	mm	lei
808863	530x325x(H)10	209,99

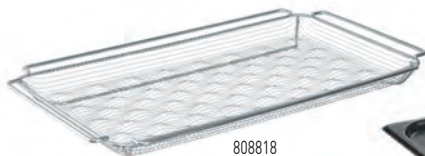

808818



808856

## COS CUPTOR PENTRU CARTOFI PRAJITI, STRIAT CONVECTOMAT FRY

- Plasa fabricata din otel inoxidabil AISI 304.
- Cadru si manere fabricate din otel inoxidabil.
- Baza striata pentru a preveni lipirea.
- Dimensiune plasa: 7x7 mm.
- Suprafata de coacere: aprox. 450x255 mm.
- Rezistent la temperaturi de pana la 200°C.
- Potrivit pentru masina de spalat vase.

cod	mm	lei
808818	530x325x(H)40	221,99

## TAVA PENTRU OUA, CU ACOPERIRE ANTIADERENTA CONVECTOMAT EGGPLATE

- 8 forme ideale pentru oua prajite, clatite, omlete.
- Formele masoara ø11 cm in partea superioara, ø8 cm in partea inferioara si au o adancime de 2 cm.

cod	mm	lei
808856	530x325x(H)26	197,99



			GN 1/1 530x325	GN 2/3 354x325	600x400	460x340
<b>TAVA - CU 4 MARGINI</b>	aluminiu cu strat Teflon™ non-stick neted		cod	808429		
				(H)10 mm		
			lei	129,99		
	aluminiu cu strat Teflon™ non-stick perforata		cod	808405	808412	
				(H)10 mm	(H)10 mm	
			lei	138,99	149,99	
	aluminiu perforata		cod	808306	808313	
				(H)10 mm	(H)10 mm	
			lei	79,99	89,99	
<b>TAVA - CU 4 MARGINI</b>	aluminiu cu strat non-stick neted		cod			808801
						(H)30 mm
			lei			314,99
	aluminiu cu strat Teflon™ non-stick perforata		cod			808221
			lei			200,99
			<b>TAVA - CU 3 MARGINI</b>	aluminiu perforata		cod
						(H)20 mm
lei		113,99				109,99
	aluminiu neted		cod			808207
						(H)20 mm
			lei			102,99
<b>TAVA BAGHETE</b>	aluminiu perforata potrivita pentru 5 baghete		cod			808238
			lei			233,99

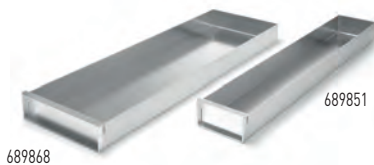

689868

689851



689875

### TAVA PATISERIE INCHISA

cod	mm	lei
689851	580x100x(H)50	67,99
689868	580x200x(H)50	87,99

### BAZA PENTRU TAVA PATISERIE INCHISA

cod	-	mm	lei
689875	potrivit pentru 689851	580x100x(H)50	137,99
689882	potrivit pentru 689868	580x200x(H)50	133,99



			GN 1/1 530x325	GN 1/2 325x265
<b>RECIPIENT PENTRU CUPTOARE</b>	otel inoxidabil		cod	816073
				(H)40 mm
			lei	<b>53,99</b>
			cod	816080
				(H)65 mm
			lei	<b>63,99</b>
			cod	816097
				(H)100 mm
			lei	<b>83,99</b>
			cod	816042
	(H)150 mm	(H)150 mm		
lei	<b>172,99</b>	<b>109,99</b>		
cod	816059	816172		
	(H)200 mm	(H)200 mm		
lei	<b>207,99</b>	<b>143,99</b>		
<b>RECIPIENT PENTRU CUPTOARE</b>	aluminiu cu strat non-stick neted		cod	805558
				(H)20 mm
			lei	<b>169,99</b>
			cod	805541
				(H)40 mm
lei	<b>179,99</b>			
cod	805534			
	(H)65 mm			
lei	<b>199,99</b>			
<b>RECIPIENT PENTRU CUPTOARE</b>	marginii rotunjite grosimea foi 1 mm pentru utilizare in cuptor pre- incalzit pana la 250-300°C		cod	800164
				(H)20 mm
lei	<b>104,99</b>			
<b>RECIPIENT PENTRU CUPTOARE</b>	aluminiu		cod	808627
				(H)40 mm
			lei	<b>119,99</b>
			cod	808634
	(H)65 mm			
lei	<b>133,99</b>			
<b>TAVA PRAJIRE</b>	aluminiu		cod	808689
				(H)40 mm
lei	<b>361,99</b>			



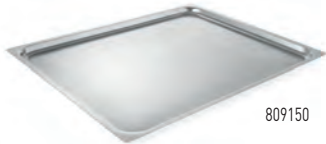

809150

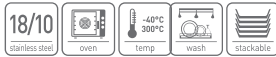

**TAVA PROFI LINE GN 2/1**

cod	GN	mm	lei
809150	GN 2/1	650x530x(H)20	<b>219,99</b>



809259

809242

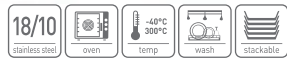

**TAVA GASTRONORM PROFI LINE**

cod	GN	mm	lei
809259	GN 1/1	530x325x(H)20	<b>87,99</b>
809242	GN 1/1	530x325x(H)40	<b>100,99</b>



808757



**TAVA ALUMINIU GN 1/1, CU FORME, CU STRAT ANTI-ADERENT**

- 6 forme, diametru 125 mm.

cod	mm	lei
808757	530x325	<b>391,99</b>



808740



**TAVA ALUMINIU GN 1/1, CU FORME**

- 6 forme, diametru 125 mm.

cod	mm	lei
808740	530x325	<b>247,99</b>



801949



**GRATAR GN**

cod	-	mm	lei
801949	placat cu crom	650x530	<b>129,99</b>

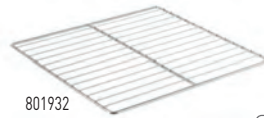

801932



**GRATAR**

cod	mm	lei
801932	354x325	<b>99,99</b>



801925

801963

801994



**GRATAR**

cod	-	mm	lei
801925	gratar transversal	600x400	<b>119,99</b>
801963	placat cu crom	600x400	<b>92,39</b>
801994	placat cu crom	600x400	<b>169,99</b>

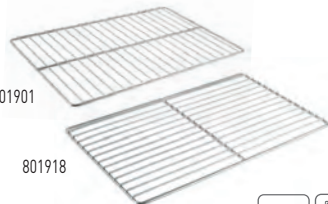

801901

801918



**GRATAR GASTRONORM**

- GN 1/1

cod	-	mm	lei
801901	realizat din otel inoxidabil AISI 304	530x325	<b>94,59</b>
801956	cromat	530x325	<b>80,99</b>
801918	din otel inoxidabil 18/10	530x325	<b>144,99</b>



partea cu  
nervuri

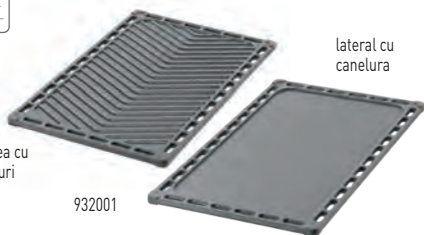

lateral cu  
canelura

932001

932018

### GRATAR FONTA

- Potrivit pentru toate gratarele Green Fire Profi Line.
- Ambele fete sunt usor de folosit, o parte neteda, o parte striata.

cod	GN	mm	lei
932001	GN 1/1	325x530	229,99

### GRATAR FONTA STRIAT

- Potrivit pentru toate aparatele barbecue Green Fire Profi Line

cod	GN	mm	lei
932018	GN 1/1	325x530	199,99



### DIFUZOR FLACARA

- Pozitionati difuzorul pentru flacara deasupra arzatorului pentru ca grasimea sa nu curga direct pe arzator
- Difuzor pentru flacara din otel inoxidabil
- Potrivit pentru toate aparatele barbecue Green Fire Profi Line

cod	mm	lei
939956	650x530	132,99



939949

939956

### EXTREME BOOSTER CURATATOR PROFESIONAL PENTRU GRATAR SI CUPTOR

- Produs gata de utilizare, puternic alcalin pentru indepartarea zilnica a depunerilor uleioase si gudroase, a grasimilor arse si a decolorarilor organice.
- Curata si degreseaza.
- Recomandat pentru spalarea zilnica a gratarului, cuptoarelor, hotei.
- Ajuta la pastrarea stralucirii naturale a suprafetii.
- Fara miros.
- pH 14.

cod	litri	lei
975039	1	25,99



Vezi filmul

975039



PIZZA, PASTE, KEBAB



## CUPTOR PENTRU PIZZA

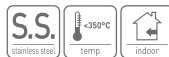

- Destinat ca echipament auxiliar pentru bucatarii mari, bistrouri si camioane alimentare
- Carcasa din otel inoxidabil AISI 18/0, care garanteaza utilizarea pe termen lung a cuptorului
- Camera din otel inoxidabil cu dimensiuni: 410x420x(H)120 mm, contine 1 pizza mare cu diametrul de pana la  $\varnothing 39$  cm sau multe feluri de mancare mici
- Partea inferioara a camerei este captusita cu piatra de samota, care acumuleaza caldura si face preparatele crocante

- Fiecare ement de incalzire cu o putere de 1000 W, cu comanda electromecanica separata
- Controlul temperaturii in intervalul de la  $50^{\circ}\text{C}$  la  $350^{\circ}\text{C}$
- Cuptorul dispune de iluminare interioara
- O usa cu maner ergonomic si o fereastră de vizualizare pentru a facilita observarea procesului de coacere
- Timer cu timp de lucru reglabil pana la 120 de minute
- Este livrat cu un cablu electric de aproximativ 1,7 m si o priza cu impamantare



## CUPTOR COMPACT PENTRU PIZZA

- Camera este incalzita de 2 elemente eficiente de incalzire: unul deasupra si unul sub camera

cod	V	W	mm	lei
220290	230	2000	580x560x(H)275	1179,00

Partea inferioara a camerei este captusita cu piatra de sampota



## CUPTOR PENTRU PIZZA CU 2 CAMERE 3000 W

- O parte neteda si o parte cu canelura pe margine

cod	V	W	mm	lei
220283	230	3000	580x560x(H)435	1499,00

Usile se deschid spre inainte



Cronometru cu timp de functionare reglabil pana la 120 min



## CUPTOARE PIZZA PRISMAFOOD

**prismafood**  
 ►► solutions

- Panou frontal din oțel inoxidabil și structura din oțel vopsit
- Izolație cu vată minerală
- Caramizi refractare în interiorul camerei de coacere
- Elementi de încălzire în camera de coacere, sus și jos
- Termostat separat pentru fiecare element de încălzire
- Temperatura - de la 50°C până la 320°C
- Dimensiuni interioare - 410x360x(H)90 mm



**MODEL  
NOU**

226674

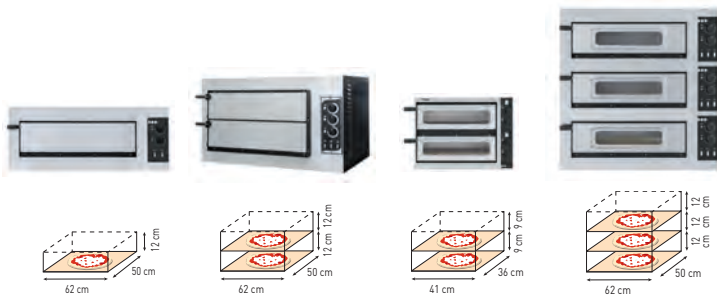

● 1 (ø45 cm)

● 1+1 (ø45 cm)

● 1+1 (ø32 cm)

● 1+1+1 (ø45 cm)

nume	BASIC 1/50 VETRO	BASIC 2/50 VETRO	BASIC 2/40 VETRO	BASIC 3/50 GLASS AND LIGHT
cod	1F010026	1F010036	226674	201046
camere	1	2	2	3
dimensiuni	915x621x(H)357 mm	915x621x(H)527 mm	567x427,5x(H)428 mm	915x690x(H)900 mm
dimensiuni interioare	620x500x(H)120 mm	2x 620x500x(H)120 mm	2x 410x360x(H)90 mm	3x 620x500x(H)120 mm
temperatura	45°C - 455°C	45°C - 455°C	50°C - 320°C	50°C - 455°C
putere/alimentare	4 kW/400 V	6 kW/400 V	2,4 kW/230 V	12 kW/400 V
lei	<b>3309,00</b>	<b>4969,00</b>	<b>3119,00</b>	<b>6799,00</b>
<b>SUPPORT</b>	224816	224816		
dimensiuni	915x621x(H)900 mm	915x621x(H)900 mm		
lei	<b>1299,00</b>	<b>1299,00</b>		



## CUPTOR PENTRU PIZZA BASIC PRISMAFOOD

**prismafood**  
solutions

- Carcasa din otel.
- Izolatie din lana minerala.
- Control mecanic.
- Camera iluminata.
- Fundul camerei este captusit cu samota.

- Incalzitoare in fiecare camera (sus si jos).
- Reglarea incalzitoarelor cu termostate independente.
- Termometru separat pentru fiecare camera.



**MODEL NOU**

1F010050

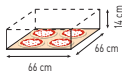

4 (ø32 cm)

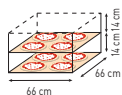

4+4 (ø32 cm)

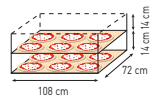

6+6 (ø35 cm)

nume	BASIC 4	BASIC 44	BASIC XXL 66
cod	1F010055	1F010050	226995
camere	1	2	2
dimensiuni	975x814x(H)413 mm	975x814x(H)745 mm	1360x844x(H)745 mm
dimensiuni interioare	660x660x(H)140 mm	2x 660x660x(H)140 mm	2x1080x720x(H)140 mm
temperatura	45°C - 455°C	45°C - 455°C	45°C - 455°C
putere/alimentare	4,7 kW/400 V	9,4 kW/400 V	18 kW/400 V
greutate	75 kg	122 kg	176 kg
lei	<b>4069,00</b>	<b>6959,00</b>	<b>11599,00</b>
<b>SUPORT</b>	226797	227107	227206
dimensiuni	975x814x(H)960 mm	975x814x(H)860 mm	1360x844x(H)860 mm
lei	<b>1299,00</b>	<b>1199,00</b>	<b>1249,00</b>



## CUPTOR PENTRU PIZZA BASIC XL

- Parte frontala construita din otel inoxidabil.
- Carcasa din otel.
- Izolatie din lana minerala.
- Control mecanic.
- Camera interioara iluminata.

**prismafood**  
solutions

- Partea inferioara a camerei este captusita cu samota.
- Incalzitoare in fiecare camera (sus si jos).
- Reglarea incalzitoarelor cu termostate independente.
- Termometru separat pentru fiecare camera.



**MODEL  
NOU**

226957

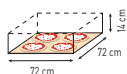

● 4 (ø35 cm)

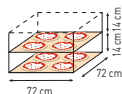

● 4+4 (ø35 cm)

nume	BASIC XL 4	BASIC XL 44
cod	226940	226957
camere	1	2
dimensiuni	1000x844x(H)413* mm	1000x844x(H)745* mm
dimensiuni interioare	720x720x(H)140 mm	2x 720x720x(H)140 mm
temperatura	45°C - 455°C	45°C - 455°C
putere/alimentare	6 kW/400 V	12 kW/400 V
greutate	77 kg	139 kg
lei	4809,00	7359,00
<b>SUPORT</b>	227152	227169
dimensiuni	1000x844x(H)960 mm	1000x844x(H)860 mm
lei	1199,00	1239,00

## CUPTOR PENTRU PIZZA BASIC SLIM LINE

- Parte frontala construita din otel inoxidabil.
- Carcasa din otel.
- Izolatie din lana minerala.
- Control mecanic.
- Camera interioara iluminata.
- Partea inferioara a camerei este captusita cu samota.
- Incalzitoare in fiecare camera (sus si jos).
- Reglarea incalzitoarelor cu termostate independente.
- Termometru separat pentru fiecare camera.

**prismafood**  
» solutions

nume	BASIC SLIM LINE 33
cod	226933
camere	2
dimensiuni	1305x489x(H)745* mm
dimensiuni interioare	2x 1080x410x(H)140 mm
temperatura	50°C – 455°C
putere/alimentare	12 kW/400 V
greutate	124,9 kg
lei	<b>7299,00</b>

<b>SUPORT</b>	227145
dimensiuni	1305x489x(H)860 mm
lei	<b>1299,00</b>

**PLACI  
EXTRA  
POATE FI  
PLASAT  
PE MASA**

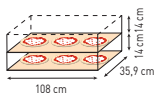

**3+3** (ø32 cm)



**MODEL  
NOU**

226933



## CUPTOARE PENTRU PIZZA PLUS XL

**prismafood**  
solutions

- Otel inoxidabil.
- Carcasa din otel vopsit negru.
- Izolatie din lana minerala.
- Control electromecanic.
- 6 elemente de incalzire in fiecare camera, 3 in partea de sus si 3 in partea de jos.
- Reglarea elementelor de incalzire cu termostate independente.
- Termometru separat pentru fiecare camera.
- Iluminatul camerei.
- Partea inferioara a camerei este captusita cu samota.
- Usa detasabila cu fereastra de vizionare.



**MODEL  
NOU**

226759

**6**  
ELEMENTE  
DE INCALZIRE  
IN FIECARE  
CAMERA

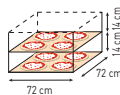

**4+4** (ø35 cm)

nume	PLUS XL 44
cod	226759
camere	2
dimensiuni	1000x844x(H)745* mm
dimensiuni interioare	2x 720x720x(H)140 mm
temperatura	45°C - 455°C
putere/alimentare	12 kW/400 V
greutate	162 kg
lei	<b>8509,00</b>
<b>SUPORT</b>	227169
dimensiuni	1000x844x(H)860 mm
lei	<b>1239,00</b>

382

**HENDI**

Pret catalog fara TVA



## CUPTOARE PENTRU PIZZA TRAYS GLASS

**prismafood**  
solutions

- Flexibilitatea ridicata datorita camerei extrem de mari le face aplicabile nu numai in pizzeriile tipice, ci si in cofetariile si brutariile, unde puteti coace o varietate de preparate direct pe samota de 600x400 mm.
- Otel inoxidabil.
- Carcasa din otel vopsit negru.
- Usa cu geamuri mari care faciliteaza observarea procesului de coacere.

- Doua manere pentru fiecare usa.
- Izolatie din lana minerala.
- Iluminare independenta pentru fiecare camera.
- Incalzitoare in seturi de 3, sus si jos pentru fiecare camera.
- Reglarea incalzitoarelor cu termostate independente pentru fiecare camera.
- Control mecanic independent pentru fiecare camera.
- Iluminare independenta pentru fiecare camera.



**MODEL NOU**

227268

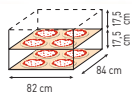

**4+4** (ø40 cm)  
**2+2** (tavi 60x40 cm)

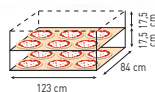

**6+6** (ø40 cm)  
**4+4** (tavi 60x40 cm)

nume	TRAYS 44 GLASS	TRAYS 66L GLASS
cod	227268	227350
camere	2	2
dimensiuni	1100x964x(H)745* mm	1500x964x(H)745* mm
dimensiuni interioare	2x 820x840x(H)175 mm	2x 1230x840x(H)175 mm
temperatura	45°C - 455°C	45°C - 455°C
putere/alimentare	13,8 kW/400 V	20,4 kW/400 V
greutate	172 kg	225 kg
lei	<b>9299,00</b>	<b>13499,00</b>
<b>SUPPORT</b>	224564	224588
dimensiuni	1100x964x(H)960 mm	1500x964x(H)960 mm
lei	<b>1519,00</b>	<b>1669,00</b>



## FORMATOR ELECTRIC ALUAT PRISMAFOOD

- Perfect pentru rularea aluatului rece pentru pizza, pasta sau ravioli
- Nu incalzeste aluatul in timpul procesarii.
- Fabricat din otel inoxidabil.

- Cantar electronic al portiilor de aluat procesate.
- Doua seturi de role ajustabile formeaza aluatul intr-un disc cu grosime de la 0 la 4 mm.
- Protectia pentru fiecare rola asigura o operare usoara si sigura.
- Reduce considerabil timpul de lucru al personalului.

**prismafood**  
solutions



Vezi filmul

Pedala electrica  
inclusa



**MODEL  
NOU**

model	PRISMAFOOD 300	PRISMAFOOD 500	PRISMAFOOD 300
cod	226599	1D010002	1D010014
numar de role	1	1	2
greutate aluat	0,08-0,21 kg	0,21-0,70 kg	0,08-0,21 kg
diametru disc aluat	ø140-300 mm	ø260-450 mm	ø140-300 mm
dimensiuni	480x335x(H)430 mm	650x345x(H)430 mm	475x375x(H)660 mm
putere	250 W	250 W	250 W
tensiune	230 V	230 V	230 V
greutate	18 kg	27 kg	28 kg
lei	2979,00	3499,00	4199,00

**MODEL  
NOU**

## ROLE ELECTRICE PENTRU ALUAT

- Perfect pentru a rula aluat rece de pizza, aluat de paste si galuste/aluat cald.
- Nu incalzeste aluatul in timpul functionarii.
- Fabricat din otel inoxidabil.
- Model patentat TOUCH & GO - cilindrul este pornit automat dupa plasarea aluatului
- Setarea duratei de functionare: 10-35 s.
- Doua seturi de role reglabile modeleaza aluatul intr-un disc cu grosime de la 0 la 4 mm.
- Dispozitivele de protectie a roletelor separate asigura o operare usoara si sigura.
- Latime de aluat rulata: 26 pana la 40 cm.

**MODEL  
BREVETAT  
TOUCH  
AND GO**



model	PRISMAFOOD „TOUCH AND GO” 400
cod	226605
numar de role	2
greutate aluat	0,21-0,70 kg
diametru disc aluat	ø260-400 mm
dimensiuni	585x435x(H)790 mm
putere	250 W
tensiune	230 V
greutate	37 kg
lei	4699,00





Vezi filmul

**prismafood**  
solutions



Pedala electrica  
inclusa

PRISMAFOOD 400

1D010028

2

0,21-0,70 kg

ø260-400 mm

585x435x(H)790 mm

250 W

230 V

37 kg

4409,00

PRISMAFOOD 500

226643

2

0,22-1,00 kg

ø260-450 mm

665x435x(H)715 mm

250 W

230 V

41 kg

4999,00



MODEL  
BREVETAT  
**TOUCH  
AND GO**

PRISMAFOOD „TOUCH AND GO“ 400

220368

2

0,22-0,90 kg

ø260-400 mm

585x435x(H)715 mm

250 W

230 V

38 kg

4869,00



## MIXERE SPIRALATE PRISMAFOOD

- Pentru uz profesional.
- Ideal pentru pizzerii, brutarii, patiserie, galuste, gogosi si amestecarea aluatului greu.
- Carcasa rezistenta si robusta fabricata din otel lacuit alb.
- Bolul, grila de protectie si spirala sunt fabricate din otel inoxidabil AISI 304.
- Protectia de siguranta cu grila faciliteaza adaugarea ingredientelor in timpul functionarii.
- Cu un microcomutator, functionarea se opreste atunci cand protectia este ridicata.
- Actionarea cu lant asigura o functionare eficienta.
- Functionarea silentioasa este garantata de un motoreductor cu baie de ulei.
- Designul spiralat asigura omogenitatea perfecta si aerarea aluatului.
- Mixerul nu incalzeste aluatul in timpul functionarii.
- Cu cronometru integrat de 30 de minute.
- Dotat cu 4 roti dintre care 2 cu frane, asigurand un transport confortabil si o utilizare usoara in bucatarie.

**prismafood**  
solutions

S.S. 18/10  
stainless steel stainless steel

**MODEL  
NOU**



11053010  
4 roti din care  
2 cu frane



Timer si intrerupator  
de siguranta

11053035

Cuva detasabila

### MIXER SPIRALA CU VAS FIX PRISMAFOOD

cod	mm	litri	greutate (kg)	productivitate (kg/h)	cuva (mm)	kg	V	W	hp	lei
11010003	290x590x(H)580	10	8	35	ø260x(H)200	40	230	370	0,5	4429,00
11053010	385x670x(H)725	22	17	56	ø360x(H)210	59	400	750	1,0	5179,00
11054010	435x750x(H)810	32	25	88	ø400x(H)260	82	400	1100	1,5	6499,00

### MIXER SPIRALA CU VAS DETASABIL PRISMAFOOD

cod	mm	litri	greutate (kg)	productivitate (kg/h)	cuva (mm)	kg	V	W	hp	lei
11051025	380x600x(H)645	10	8	35	ø260x(H)200	56	230	370	0,5	5859,00
11053035	390x670x(H)735	22	17	56	ø360x(H)210	81	400	750	1,0	6799,00
11054035	435x750x(H)810	32	25	88	ø400x(H)260	95	400	1100	1,5	8499,00

## MIXERE SPIRALATE CU 2 VITEZE PRISMAFOOD

- Pentru uz profesional.
- Ideal pentru pizzerii, brutarii, patiserie, galuste, gogosi si pentru amestecarea aluatului greu.
- Carcasa rezistenta si robusta fabricata din otel lacuit alb.
- Bolul, grila de protectie si spirala sunt fabricate din otel inoxidabil AISI 304.
- Protectia de siguranta cu grila faciliteaza adaugarea ingredientelor in timpul functionarii.
- Cu un microcomutator, functionarea se opreste atunci cand protectia este ridicata.
- Actionarea cu lant asigura functionarea eficienta.
- Buton cu 2 angrenaje pentru schimbarea vitezei de amestecare - a doua treapta permite o hidratare mai mare a aluatului si un aluat mai bine framantat.
- Functionarea silentioasa este garantata de un motoreductor cu baie de ulei.
- Designul spiralat asigura omogenitatea perfecta si aerarea aluatului.
- Mixerul nu incalzeste aluatul in timpul functionarii.
- Cu cronometru integrat de 30 de minute.
- Dotat cu 4 roti dintre care 2 cu frane, asigurand un transport confortabil si o utilizare usoara in bucatarie.
- 2 optiuni din care puteti alege: cu cap si bol fixate sau cu cap inaltator si bol detasabil.

**prismafood**  
solutions

**S.S.** 18/10  
stainless steel stainless steel

**MODEL NOU**



4 roti din care  
2 cu frane



Timer si intrerupor  
de siguranta

Cuva detasabila

## MIXER CU BOL FIX SI 2 VITEZE PRISMAFOOD

cod	mm	litri	greutate (kg)	productivitate (kg/h)	cuva (mm)	kg	V	W	hp	lei
222867	385x670x(H)725	22	17	56	360	750/1100*	1,0/1,5*	400	62	6269,00
222874	435x750x(H)810	32	25	88	400	1100/1700*	1,5/1,70*	400	82	7339,00
222898	480x805x(H)850	48	42	128	450	1500/2200*	2	400	98	8699,00

## MIXER CU BOL DETASABIL SI 2 VITEZE PRISMAFOOD

cod	mm	litri	greutate (kg)	productivitate (kg/h)	cuva (mm)	kg	V	W	hp	lei
222911	390x670x(H)735	22	17	56	360	750/1100*	1,0/1,5*	400	81	7909,00
222928	435x750x(H)810	32	25	88	400	1100/1300*	1,5/1,75*	400	95	9149,00
222935	480x815x(H)850	41	35	112	450	1100/1700*	1,5/2,3*	400	114	9699,00

\* in functie de viteza selectata

**CUTIE ALUAT PIZZA**

- Mentine prospețimea aluatului și continuitatea procesului de dospire.
- Stivuibilă – cu sau fără capace.
- Se poate spăla în mașina de spălat vase.

**CARE AR TREBUI SA FIE CUTIA DE ALUAT IDEALA PENTRU PIZZA?**

**Etans**

Una dintre cele mai importante caracteristici care trebuie luate în considerare este etanșeitatea. Previne uscarea aluatului în perioadele de fermentație mai lungi și îmbunătățește lucrul cu aluatul.

**Ecologic**

Utilizarea cutiilor reutilizabile închise, etanșe are un impact asupra reducerii consumului de folie utilizată pentru acoperirea aluatului. Cutiile din plastic sunt durabile și pot fi utilizate timp de mai mulți ani.

**Fabricat din material adecvat**

Cutiile tradiționale italiene de dospire a aluatului au fost realizate din lemn, dar cutiile moderne au mai multe avantaje. Pe lângă faptul că sunt compacte, au un impact benefic asupra formei și structurii aluatului. Timpul adecvat de creștere a aluatului asigură crearea unei structuri adecvate care să se transpună într-un confort de lucru - de obicei aluatul poate fi întins mai ușor și mai rapid. Acest lucru nu este posibil folosind cutii metalice care perturbă procesul de creștere a aluatului. Suprafața de plastic este, de asemenea, netedă, prevenind lipirea paninelor de aluat și facilitând îndepărtarea din cutie după creștere.

**Fara margini rotunjite în cutie**

Cutiile speciale cu aluat pentru pizza facilitează tăierea și îndepărtarea aluatului cu păstrarea formei sale. Contrar cutiilor GN utilizate de obicei, cu margini rotunjite, împiedicând îndepărtarea bilei fără distrugerea formei acesteia.

Mai multe pâine de aluat sunt depozitate în același timp în timpul dospirii. Cutiile stivuite ocupă mai puțin spațiu. Cutiile stivuite sunt, de asemenea, mai ușor de deplasat, deoarece nu pot cădea.

PIZZA, PASTE, KEBAB



880906



880982



880975

**NOU**

**CUTIE PENTRU ALUAT DE PIZZA 600X400**

- Fabricat din polietilena alimentară, sigur în contact cu alimentele.
- Pot fi stivuite – cu sau fără capace.
- Capac vandut separat (880968).
- Poate fi spălat în mașina de spălat vase

cod	litri	mm int.	mm	lei
880906	14	565x365x(H)70	600x400x(H)75	44,99
880913	18	565x365x(H)90	600x400x(H)95	48,99
880920	24	565x365x(H)125	600x400x(H)130	59,99
880968	capac		600x400	42,99

**CUTIE PENTRU ALUAT DE PIZZA GN1/1**

- Fabricat din polietilena (HDPE), fără BPA.
- Destinat transportului/depozitării aluatului crud de pizza.
- Colțuri rotunjite – ușor de curățat.
- Pot fi stivuite (fără capac).
- Rezistență termică: între -40 °C și 90 °C.

cod	mm	lei
880975	530x325x(H)90	79,99
880982	capac	52,99

## FORMATOR ALUAT PIZZA

**prismafood**  
solutions

- Echipament profesional pentru prepararea aluatului pentru pizza.
- Acesta permite prepararea unor cantitati mari de aluat fara un efort deosebit.
- Carcasa si panouri fabricate din otel inoxidabil
- Panouri placate cu crom
- Spatiere panouri: max. 110 - 115 mm
- Setari independente ale temperaturii de lucru pentru panourile superior si inferior, cu afisaje digitale separate si indicatoare luminoase

- Reglare usoara a grosimii aluatului cu ajutorul manetei
- Ecranul mobil asigura procesarea in siguranta a aluatului
- Iluminatul pe doua laturi ale panourilor permite observarea procesului de presare a aluatului
- Reglarea timpului de presare a aluatului
- Temperatura maxima de incalzire a placilor: 170 °C
- Eficienta: aprox. 360 cruste pizza/ora



**MODEL NOU**



Capacul mobil asigura procesarea in siguranta a aluatului

Iluminat pe 2 laturi ale cadranelor

Pentru a regla durata de calcare a aluatului

1P010015

### FORMATOR ALUAT PIZZA 33

- Pentru formarea aluatului crud pentru pizza cu un diametru maxim de ø33 cm.
- Greutate maxima a aluatului inainte de formare: 250-270 g.
- Greutate neta: 121 kg.

cod	mm	lei
1P010005	470x660x(H)825	19999,00

### FORMATOR ALUAT PIZZA 45

- Pentru formarea aluatului crud pentru pizza cu un diametru maxim de ø45 cm.
- Greutate maxima a aluatului inainte de formare: 600-650 g.
- Greutate neta: 163 kg.

cod	mm	lei
1P010015	655x750x(H)855	23999,00

### FORMATOR ALUAT PIZZA 50

- Pentru formarea aluatului crud pentru pizza cu un diametru maxim de ø50 cm.
- Greutate maxima a aluatului inainte de formare: 700-750 g.
- Greutate neta: 172 kg.

cod	mm	lei
1P010025	655x750x(H)855	27999,00



**PLANSA DE PIZZA CU MANER**

- Fabricat din fibre de lemn comprimat.
- Rezistent la temperaturi de pana la 175 °C timp de 2 minute, pana la 70 °C timp de 2 ore.
- Presiunea ridicata utilizata in timpul productiei face acest tocator mai rezistent decat unul fabricat din lemn obisnuit.
- Nu necesita intretinere (nu este nevoie de ulei sau inalbitor).
- Culoarea se modifica in timpul utilizarii, oferindu-i un aspect natural.
- Potrivit pentru masina de spalat vase.



505533

**DISTANTIER PENTRU PIZZA - 500 BUC.**

- Inaltime: 35 mm.

cod	ambalat pe	lei
709900	500	54,99



709900



617700



617731

**DISPOZITIV PRINDERE TAVA**

- Potrivit pentru toate tipurile de tavi pizza.

cod	mm	lei
617700	(L)190	29,99

**DISPOZITIV PRINDERE TAVA**

- Potrivit pentru toate tipurile de tavi pizza.

cod	mm	lei
617731	(L)200	36,99



617014



617007

**FELIATOR PIZZA**

- Lama din otel inoxidabil, maner din polipropilena.
- Cu sistemul de codare color HACCP, functioneaza cu clipsuri usor de amplasat.

cod	ø	lungime (mm)	lei
617014	ø100	(L)230	35,99

**FELIATOR PIZZA**

- Lama din otel inoxidabil, maner din polipropilena.
- Cu sistemul de codare color HACCP, functioneaza cu clipsuri usor de amplasat.

cod	ø	lungime (mm)	lei
617007	ø100	(L)230	15,99



### PALETA PENTRU PIZZA CU MANER SCURT, PATRATA, PERFORATA

- Ideal pentru utilizare in spatii mici
- Fabricat din aluminiu anodizat
- Usor si durabil
- Perforatie pentru scurgerea excesului de faina
- Maner scurt
- Maner din silicon fara incalzire

cod	mm	lei
618073	300x660	124,99
618066	350x710	139,99



### PALETA DE PIZZA PERFORATA CU MANER SCURT, PATRATA

- Fabricata din aluminiu anodizat usoara si rezistenta.
- Dotata cu un maner scurt, ideala pentru spatii compacte.
- Maner din silicon la capatul manerului, protejand impotriva caldurii.

cod	mm	lei
618080	350x710	154,99
618097	300x660	139,99



### PALETA DE PIZZA PATRATA CU MANER SCURT

- Ideal pentru spatii mici
- Maner scurt din lemn
- Cap din aluminiu
- Rezistenta termica ridicata

cod	mm	lei
618035	305x660	69,99
618042	355x710	79,99
618059	405x760	89,99

\* Dimensiunile pot varia usor datorita prelucrarii artisanale.



### TABLA STRADALA

- Neagra, cu rama lemn

cod	mm	lei
664001	500x450x(H)850	269,99
664018	700x600x(H)1200	422,99



### PALETA PIZZA ROTUNDA

- Usor si robust, din aluminiu anodizat.

cod		mm	lei
617151		230x1200	<b>139,99</b>
617168	perforata	230x1200	<b>159,99</b>



### PALETA PENTRU PIZZA ROTUNDA, PERFORATA

- Fabricat din aluminiu anodizat dur, facandu-l mai rezistent la uzura, la abraziune si la coroziune.
- Dotat cu un maner scurt, ideal pentru spatii compacte.
- Maner din silicon la capatul manerului, protejand impotriva caldurii.

cod		mm	lei
618103		230x1200	<b>174,99</b>



### PALETA PIZZA ROTUNDA

- Un maner glisant, ceea ce face preluarea pizzei din cuptor foarte usoara.

cod		mm	lei
617182		230x1200	<b>169,99</b>
617199	perforata	230x1200	<b>149,99</b>



### PALETA DE PIZZA PATRATA

- Usor si robust, din aluminiu anodizat.

cod		mm	lei
617113		305x1320	<b>159,99</b>
617137	perforata	305x1320	<b>199,99</b>
617120		405x1320	<b>189,99</b>
617144	perforata	405x1320	<b>229,99</b>



### PALETA PIZZA PATRATA

cod	mm	lei
617175	305x1320	149,99



### PALETA PENTRU PIZZA, PATRATA

- Pentru utilizare in pizzerii si restaurante
- Maner lung din lemn
- Cap din aluminiu
- Rezistent la caldura

cod	mm	lei
617816	305x1320	77,99
618028	355x1320	94,99
617861	405x1320	109,99

### PERIE CURATARE CUPTOR PIZZA

- Perie fabricata din sarma alama.
- Maner din lemn, detasabil, prins la capat cu surub.
- Razuitoare din otel.

cod	mm	lei
525630	930x260	118,99



### PERIE CURATARE PENTRU CUPTOR PIZZA

- Perie de cupru cu maner din aluminiu.

cod	mm	lei
525593	(L)1320	149,99



**NOU**

### LOPATA PENTRU CENUSA

- Cuplaj realizat din otel inoxidabil AISI 430.
- Maner realizat din aluminiu anodizat.
- Maner ergonomic realizat din polipropilena.
- Cu un orificiu pentru depozitare usoara.
- Potrivit pentru masina de spalat vase.

cod	mm	lei
618196	1320x215	186,99





617779

617786

617793

zestav  
617748

525647

525685

525661

617762

### PALETA PENTRU PIZZA CU MANER GLISANT

- Din otel inoxidabil, manere din plastic.
- Pentru intoarcere si scoatere pizza din cuptor.

cod	-	mm	lei
617779		ø200x1700	<b>409,99</b>
617786	perforata	ø220x1700	<b>459,99</b>

### PLAETA PIZZA VENEZIA

- Din otel inoxidabil, manere din plastic.

cod	ø	lungime (mm)	lei
617793	ø260	(L)1350	<b>239,99</b>

### 3 ACCESORII PIZZA VENEZIA

- Pentru cuptoare de dimensiuni medii. 3 accesorii lungime 1350mm: paleta din aluminiu, paleta rotire pizza, perie pentru curatarea cuptorului cu fire din alama.

cod	mm	lei
617748	(L)1350	<b>799,99</b>

### PERIE DE CURATARE A CUPTORULUI DE PIZZA CU PERI DE ALAMA - VERTICALA

- Perie moale, raclata din otel.

cod	-	mm	lei
525647	verticala	1700x55	<b>409,99</b>
525654	Perie verticala pentru curatarea cuptorului cu fire din alama	170x55	<b>119,99</b>

### PERIE PENTRU CUPTOR ROTUNJITA VENEZIA PIZZA CU PERI DE ALAMA

- Perie moale, raclata din otel.

cod	-	mm	lei
525685		1350x150	<b>239,99</b>
525692	Perie pentru curatarea cuptorului cu firme din alama	150x55	<b>94,99</b>

### PERIE DE CURATARE A CUPTORULUI DE PIZZA CU PERI NATURALI

- Perie moale, raclata din otel.

cod	-	mm	lei
525661		1700x220x(H)70	<b>379,99</b>
525678	Perie de inlocuire cu peri naturali	220x70	<b>109,99</b>

### PALETA PIZZA SI SUPORT PENTRU 3 PERII

- De sine statator.
- Structura otel inoxidabil, baza si suporturi de lemn.

cod	mm	lei
617762	420x240x(H)1600	<b>1199,00</b>

\* Dimensiunile pot varia usor datorita prelucrarii artisanale.



617847

617830

617878

617854

617823

617809



Lilly Codroipo este cel mai cunoscut producator italian de accesorii profesionale pentru pizza



### PLAETA PIZZA SOLE MIO - ALUMINIU PERFORAT

- Super usor si robust, din aluminiu anodizat auriu
- Gauri pentru a indeparta excesul de faina
- Marginea ascutita si suprafata micro perforata pentru o mai usor decojire si ridicare

cod	mm	lei
617830	1700x330	679,99
617847	1700x500	859,99

### PALETA PENTRU PIZZA ITALIA 3D - ALUMINIU PERFORAT

- Super usor si robust, din aluminiu anodizat negru.
- Gauri pentru a indeparta excesul de faina.
- Marginea ascutita si suprafata cu nervuri pentru o mai usoara decojire si ridicare.

cod	mm	lei
617809	1700x320	739,99
617823	1700x500	939,99

### PALETA PIZZA ORCHIDEA - ALUMINIU

- Usor si robust, din aluminiu anodizat.
- Marginea ascutita si suprafata microperforata pentru o mai usor decojire si ridicare

cod	mm	lei
617854	1700x330	619,99
617878	1700x500	819,99

617694



### PALETA PIZZA PENTRU CUPTOARE TUNEL

- Otel inoxidabil, maner din plastic.

cod	ø	lungime (mm)	lei
617687	ø330	(L)500	239,99
617694	ø400	(L)570	270,99

\* Dimensiunile pot varia usor datorita prelucrarii artizanale.

Pret catalog fara TVA

HENDI

395





618165

**NOU**

### PALETA PENTRU PIZZA

- Fabricata din aluminiu
- Cu 2 fete 3D, aluatul nu se lipeste de paleta
- Perforata - excesul de faina sau semolina este inlaturat
- Maner curbat patentat:
  - Utilizare ergonomica
  - Forma manerului creste rezistenta, prevenind ruperea paletelor
  - Permite plasarea pizzei in spatele cuptorului, fara sa atingeti pizza asezata in fata
- Dimensiunile pot varia usor datorita procesului de fabricatie manual

cod	mm	lei
618158	325x1800	<b>873,99</b>
618165	350x1500	<b>1009,00</b>
618141	325x1475	<b>842,99</b>
618172	350x1840	<b>1049,00</b>

**NOU**

618134



### PALETA PIZZA OLIMPIA

- Fabricata din otel inoxidabil AISI 304
- Cu 2 fete 3D, aluatul nu se lipeste de paleta
- Perforata - excesul de faina sau semolina este inlaturat
- Maner mobil confortabil - ofera mai mult control
- Dimensiunile pot varia usor datorita procesului de fabricatie manual

cod	mm	lei
618134	230x1670	<b>642,99</b>





Vezi filmul

855546



### RAZUIITOR ALUAT - FLEXIBIL

- Otel inoxidabil, cu maner din plastic.

cod	mm	lei
855546	(L)120	79,99

855553



### RAZUIITOR ALUAT

- Otel inoxidabil, maner din plastic.

cod	mm	lei
855553	(L)120	89,99
855560	(L)160	99,99

855584



### RAZUIITOR

- Otel inoxidabil, cu maner din plastic.

cod	mm	lei
855584	(L)260	82,99

855591



### PALETA SERVIRE PIZZA

- Otel inoxidabil, cu maner din plastic.

cod	mm	lei
855591	280x90x(H)30	94,99

855614



### PALETA SERVIRE PIZZA

- Fabricat din otel inoxidabil, maner de plastic

cod	mm	lei
855614	(L)330	109,99

855577



### PALETA SERVIRE PIZZA

- Otel inoxidabil, cu maner din plastic.

cod	mm	lei
855577	(L)370	149,99

523919



### PALETA SERVIRE PIZZA

- Otel inoxidabil, cu maner din plastic.

cod	mm	lei
523919	120x250	169,99

617717



### DISPOZITIV PRINDERE TAVA

- Fabricat din otel inoxidabil cu maner din plastic.

cod	mm	lei
617717	(L)250	183,99

855522



### POLONIC PIZZA

- Otel inoxidabil, cu maner din plastic.

cod	-	lei
855522	90 g	144,99

617021



### TAIETOR PIZZA

cod	mm	lei
617021	ø100x260	259,99

617038



### FELIATOR PIZZA - CURBAT

cod	mm	lei
617038	ø100x120	259,99

\* Dimensiunile pot varia usor datorita prelucrarii artisanale.

PIZZA, PASTE, KEBAB





616994

### PLATOU DIN LEMN PENTRU SERVIRE

- Folosit pentru prezentarea produselor proaspat scoase din cuptor.
- Fabricat din lemn durabil, rezistent la temperatura

cod	mm	lei
616994	600x400x(H)7	284,99

### PLANSA PIZZA CU MANER

- Fabricat din lemn rezistent, rezistent la temperatura.
- Folosit pentru servire.

cod	mm	lei
617724	535x305x(H)10	89,99

### LOPATA DE PIZZA DIN LEMN

- Pentru pizzerii si brutarii
- Din lemn de fag, lipit
- Varful lopetii este usor ascutit pentru o aplicare usoara a aluatului
- La capatul manerului exista o gaura care faciliteaza agatarea lopatei
- Datorita tehnologiilor de fabricare a lamelor, acestea nu trebuie expuse contactului excesiv cu umezeala.

cod	mm	lei
617212	1100x300	119,99
617236	1130x350	171,99

### AGITATOR DE LEMN

- Pentru amestecarea unor cantitati mari de supe si a altor vase lichide si semi-lichide in oale, cupru, tigai. Produse dintr-o singura bucata de lemn verde, care impiedica separarea stratului in produsele din lemn lipit. Exceptional durabile.

cod	mm	lei
520604	700x95	95,99
520611	1000x95	109,99
520628	1250x95	125,99



617724



617212

617236

520604

520628





design by  
Robert Bronwasser

Maner cu orificiu  
pentru agatare

Maner ergonomic,  
pentru taiere usoara

Lama groasa si rigida

Garda pentru lama  
solida - asigura ghidajul  
lamei de taiere

Greutate 325 g

ø97 mm

Design modern conceput  
de Robert Bronwasser

Constructie solida,  
cu o lama precisa  
si ascutita

Niturile netede  
asigura igiena

618127

**NOU**

18/10  
stainless steel

PP  
polypropylene

food contact

## DISPOZITIV DE TAIERE PIZZA HEAVY-DUTY HENDI PIZZER

- HENDI PIZZER este un feliator pentru pizza profesional heavy-duty, al carui design este conceput de Robert Bronwasser
- PIZZER dispune de o lama de calitate, groasa si rigida care permite taierea usoara a feliilor de pizza. Fie ca este vorba de o crusta crocanta sau moale HENDI PIZZER feliaza fara probleme
- Feliatorul cantareste 325g, fapt ce indica o calitate premium
- Manerul este fabricat din polipropilena, in timp ce lama si celelalte componente sunt fabricate din otel inoxidabil AISI 304

- Impreuna, acestea formeaza un accesoriu de bucatarie extrem de rezistent
- Lama este securizata cu o garda groasa, iar niturile netede asigura igiena - spre deosebire de feliatoarele traditionale
- Feliatorul este usor curbat si perfect echilibrat, oferind un grad ridicat de confort in utilizare
- Manerul dispune de un orificiu pentru agatare, pentru depozitare usoara
- Se poate spala la masina de spalat vase

cod	mm	g	lei
618127	ø97x130	325	104,99





rb design by Robert Bronwasser

855621

**NOU**



### POLONIC PENTRU SOS PIZZAHEAVY-DUTY

- Polonic pentru sosuri realizat din otel inoxidabil AISI 304 cu un maner din PP (polipropilena).
- Proiectat de renumitul designer olandez Robert Bronwasser - functional, ergonomic si rezistent.
- Baza plata pentru portionarea si distribuirea usoara a sosului.
- Capacitate: 90 ml.
- Potrivit pentru masina de spalat vase.

cod	litri	mm	lei
855621	0.09	330x72x(H)27	<b>69,99</b>



rb design by Robert Bronwasser

855638

**NOU**



### SPATULA PENTRU PIZZA HEAVY-DUTY

- Pentru ridicarea si indepartarea cu usurinta a aluatului de pizza din cutie, divizarea acestuia si raziurea.
- Piesa de lucru fabricata din otel inoxidabil AISI 301.
- Maner fabricat din PP (polipropilena).
- Proiectat de renumitul designer olandez Robert Bronwasser - functional, ergonomic si rezistent.
- Potrivit pentru masina de spalat vase.

cod	mm	lei
855638	263x132x(H)17	<b>57,99</b>



rb design by Robert Bronwasser

855645

**NOU**



### PORTIONATOR DE ALUAT PENTRU PIZZA HEAVY-DUTY

- Lama confectionata din otel inoxidabil AISI 301 cu un maner confectionat din silicon.
- Lama este flexibila.
- Proiectat de renumitul designer olandez Robert Bronwasser - functional, ergonomic si rezistent.
- Potrivit pentru masina de spalat vase.

cod	mm	lei
855645	130x95x(H)13	<b>33,99</b>



**NOU**

855492



### LINGUA PENTRU SOS DE PIZZA

- Fabricat din otel inoxidabil AISI 304.
- Manerul indoit si partea inferioara plata faciliteaza portionarea si distribuirea sosului.
- Maner cu orificiu pentru depozitare comoda.
- Potrivit pentru masina de spalat vase.
- Disponibil in 2 marimi.

cod	mm	lei
855539	380x65	<b>39,99</b>
855492	280x65	<b>33,99</b>



## FARFURII PENTRU PASTE SI PIZZA.

- Fabricat din portelan rezistent vitrat.
- Potrivit pentru cuptorul cu microunde.
- Potrivit pentru masina de spalat vase.
- Nu este potrivit pentru cuptor.



777855

### FARFURIE PIZZA BAROCCO

cod	mm	lei
777855	ø330	39,99
768792	ø310	32,99

**NOU**



778937

### COLECTIA DE FARFURII PENTRU PIZZA RECIPE BLACK

cod	mm	lei
778937	ø330	36,99
768761	ø310	32,99

**NOU**



778944

### FARFURIE PENTRU PIZZA COLECTIA RECIPE BRICK RED

cod	mm	lei
778944	ø330	36,99
768778	ø310	32,99

PIZZA, PASTE, KEBAB



769935

### PLACA DE PASTE BAROCCO

cod	mm	lei
769935	ø275	59,99





774847

774861

774854

774878



769928

### FARFURIE PENTRU PASTE SPECIALE

cod	culoare	mm	lei
774830	Alb	ø280	20,99
774847	Alb	ø330	24,99
774854	Gri inchis	ø330	29,99
774861	Galben	ø330	29,99
774878	Portocaliu	ø330	29,99
768242	Galben	ø310	29,99 <b>N</b>
768259	Portocaliu	ø310	29,99 <b>N</b>
768235	Gri inchis	ø310	29,99 <b>N</b>

### FARFURIE SPECIALE PENTRU PASTE

cod	mm	lei
769928	ø265	35,99

**NOU**

774885

**NOU**

778906

**NOU**

778920

### FARFURIE PENTRU PIZZA MODEL GRANIT

cod	mm	lei
774885	ø330	29,99
768815	ø310	29,99

### FARFURII PENTRU PIZZA COLECTIA DROPS

cod	mm	lei
778906	ø310	32,99
778913	ø330	36,99

### FARFURIE PENTRU PASTE COLECTIA DROPS

cod	mm	lei
778920	ø275	56,99



769911



769904



774892

### FARFURIE PENTRU PIZZA CRETE

cod	mm	lei
769911	ø330	42,99
768785	ø310	35,99 <b>N</b>

### PLACA PENTRU PASTE CRETE

cod	mm	lei
769904	ø265	42,99

### FARFURIE PENTRU PIZZA TRADITIONAL

cod	mm	lei
774892	ø330	32,99 <b>N</b>
768808	ø310	32,99





617069



617922



616918

## TAVA PIZZA

- Fabricata din otel
- Ideala pentru distribuirea uniforma a caldurii in timpul coacerii

cod	mm	lei
617069	ø200x(H)25	21,99
617076	ø220x(H)25	25,99
617083	ø240x(H)25	27,99
617090	ø260x(H)25	29,99
617106	ø280x(H)25	30,99
617205	ø300x(H)25	32,99
617304	ø320x(H)25	34,99
617403	ø360x(H)25	39,99
617410	ø400x(H)25	44,99
617427	ø450x(H)38	62,99
617434	ø500x(H)38	64,99
617489	ø600x(H)25	79,99

## TAVA PENTRU PIZZA

- Fabricat din otel carbon cu o carcasa din aluminiu.
- Perfecta pentru coacere pizza.
- Grosimea foii: 0,75 mm.

cod	mm	lei
617885	ø200x(H)25	26,99
617892	ø220x(H)25	32,99
617908	ø240x(H)25	35,99
617915	ø260x(H)25	39,99
617922	ø280x(H)25	41,99
617939	ø300x(H)25	43,99
617946	ø320x(H)25	44,99
617953	ø360x(H)25	54,99
617960	ø400x(H)25	67,99
617977	ø450x(H)38	89,99
617984	ø500x(H)38	99,99
617991	ø600x(H)25	125,99

## TAVA PERFORATA PENTRU PIZZA

- Pentru utilizare in restaurante, cantine si hoteluri care servesc pizza
- Tava pentru pizza este realizata din otel carbon acoperit cu oxid de fier care asigura o protectie excelenta impotriva coroziunii
- Coacere uniforma datorita perforatiei speciale a tavii
- Perforatii care masoara: Ø 3 mm
- Rezistenta la caldura pana la: 420°C
- Sigur in contact cu alimentele
- Adecvat pentru utilizarea in cuptor
- ATENTIE: Nu este sigur pentru masina de spalat vase si nici pentru cuptorul cu microunde

cod	fund (mm)	mm	lei
616918	ø261	ø291x(H)24	32,99
616901	ø240	ø270x(H)25	35,99
616925	ø281	ø311x(H)23	39,99
616932	ø324	ø352x(H)23	44,99
616949	ø381	ø411x(H)23	59,99



### TAVA DE PIZZA DREPTUNGIULARA

- Fabricat din otel albastru. Ideal pentru distributia uniforma a caldurii la coacere.

cod	mm	lei
808276	600x400x(H)25	<b>89,99</b>

808276

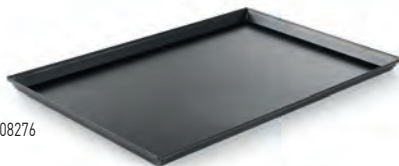

### TAVA SITA PIZZA

- Constructie solida  
- Ideala pentru coacerea uniforma

cod	mm	lei
617502	ø230	<b>10,99</b>
617519	ø250	<b>11,99</b>
617526	ø280	<b>12,99</b>
617533	ø300	<b>15,99</b>
617540	ø330	<b>16,99</b>
617557	ø360	<b>18,99</b>
617564	ø400	<b>20,99</b>
617465	ø430	<b>22,99</b>
617571	ø450	<b>23,99</b>
617588	ø508	<b>28,99</b>
617595	ø600	<b>51,99</b>



617533



505540



ø500 si 600 mm au  
o baza ranforsata

### PLANSETE PIZZA

- Fabricata din lemn de fag brut  
- Cu caneluri pentru a ajuta taierea in 6 parti egale

cod	mm	lei
505540	ø300	<b>52,99</b>
505557	ø350	<b>59,99</b>
505564	ø400	<b>69,99</b>
505571	ø450	<b>79,99</b>
505588	ø500	<b>119,99</b>



810361



### STAND PIZZA CU 14 NIVELURI

- Tine pana la 14 plansete sau tavi pentru pizza.

cod	mm	lei
810361	300x305x(H)680	<b>229,99</b>





Vezi filmul



709849

### GEANTA LIVRARE MANCARE

- Geanta are doua manere si este prevazuta cu fermoar
- Datorita izolatiei de inalta calitate, preparatele sunt pastrate calde sau reci.
- Compartimentul mare poate fi impartit in doua cu separatorul cu velcro inclus.
- Fabricat din poliester rezistent, usor de curatat.
- Oferă spatiu pentru pana la 6 cutii cu preparate.
- Prevazut cu o husa pentru documente in partea de sus.

cod	mm	lei
709849	440x260x(H)310	119,99

Buzunar superior transparent pentru facturi.



Maner din plastic antiderapant.

Cadru detasabil.

Izolatie suplimentara.



Vezi filmul



709818

### GEANTA LIVRARE PIZZA

- Cu manere usor de ajustat
- Fabricata dintr-un material tare si usor de curatat
- Are o portiune transparenta pentru facturi

cod	capacitate	mm	lei
709825	4 cutii	360x360x(H)200	99,99
709818	4 cutii	460x460x(H)210	114,99
709863	2 cutii	650x650x(H)150	179,99

### STRAT IMPERMEABIL

Geanta este confectionata dintr-un material de inalta calitate care ii protejeaza continutul impotriva apei si a vantului.

LIVRARE USORA CHIAR CAND PLOUA SAU NINGE



### INTERIOR SPATIOS

Rucsacul are o capacitate de 72 litri, ceea ce inseamna ca poti livra pana la: 10 cutii de pizza\* sau 8 salate\* + 6 feluri principale\* + 6 supe\*

\* pentru masurare s-a folosit ambalaj standard de livrare.

### RAFT TERMIC REGLABIL

Un raft care imparte compartimentul in doua parti. Alegeți un loc pentru salate si deserturi. Pune mancaturile fierbinti intr-un compartiment separat.

RECE JOS, CALD SUS

### SEPARATOARE

Rucsacul are 5 separatoare semicirculare in partea inferioara. Acestea asigura izolarea termica a compartimentului gentii fata de sol si impiedica uzura tesaturii exterioare.

CONTINUTUL ESTE IN SIGURANTA ATUNCI CAND LASI GEANTA JOS

### PERETE CU TREI STRATURI CU INSERTIE DE PVC

Permeabilitate la temperaturi scazute datorita sistemului multistrat al peretilor in care insertia compartimentului din PVC joaca un rol important. Intareste intreaga structura si asigura o izolare termica eficienta.

TEHNOLOGIA THERMO INSTANT TINE MANCAREA CALDA PENTRU MAI MULT DE 1,5 ORE

### RUCSAC IZOLAT PENTRU LIVRAREA ALIMENTELOR

- Rucsac usor, cu bretele mari, reglabile, captusite si cu parte captusita din spate pentru confort.
- Dotat cu curea reglabila pentru stabilitate sporita.
- Rezistent la apa datorita utilizarii unui poliester durabil 600D.
- Compartiment mare cu raft reglabil, velcro.
- Poate tine pana la 10 cutii de pizza.
- Compartimentul are doua straturi de izolat, spuma PE si folie de aluminiu.

### MULTIFUNCTIONAL

Echizat cu:

- Curea piept/talie
  - Carlige pentru accesoriile de plata pe curele
  - Sistem Comfort - captureseala moale, ventilata, cu spuma usoara pe spate si ham
  - Buzunar impermeabil pentru bonuri
- FUNCTIONALITATE CONFORT "HANDS-FREE"

### CENTURILE STRUCTURALE SI DE SUPT CA IN TEHNOLOGIA AUTOMOBILE

Benzi de tesatura din polipropilena in centura.

Durabil, puternic, cu un design grozav care va rezista ani de zile.

FARA DESTAMARE SAU DESCOASERE

- O parte a rucsacului poate fi deschisa cu un fermoar pentru acces usor.
- Cu manere mari de transport captusite in partea superioara si un suport transparent pentru card in partea din spate.
- Banda reflectorizanta montata in exterior pentru o securitate suplimentara.

cod	mm	lei
709801	410x410x(H)480	279,99



709870

### GEANTA DE LIVRARE PIZZA 45 CM KITCHEN LINE

- Destinat companiilor de catering care
- Fabricat din poliester durabil (600D exterior, 210D interior) cu izolatie din spuma de 5 mm
- Usor de curatat
- Inchidere cu velcro pentru inchiderea rapida si stransa a gentii
- Manere care asigura transportul stabil si confortabil al gentii
- Un buzunar transparent pentru bancnote deasupra

cod	mm	lei
709870	470x470x(H)210	85,99



709764



### GEANTA IZOLATA PENTRU LIVRAREA ALIMENTELOR

- Ideal pentru companiile de catering care livreaza produse alimentare.
- Izolatie de inalta calitate, cu trei straturi, mentine temperatura potrivita atat calda cat si rece, garantand satisfactia clientilor.
- Poliester negru rezistent si impermeabil la exterior, strat de spuma PE in mijlocul peretilor, folie de aluminiu la interior izoleaza si reflecta caldura.
- Toate zonele de contact sunt realizate din materiale usor de curatat.
- Aduagarea de placi in pereti rigidizeaza geanta si previne deformarea in timpul transportului.
- Capacul este prevazut cu un magnet care asigura o inchidere stransa de fiecare data.
- Buzunar inchis cu velcro deasupra gentii si buzunar transparent pe partea din fata a gentii pentru facturi, pliante etc.
- Manerele sunt prevazute cu cauciuc pentru transport confortabil.
- Disponibil in 4 dimensiuni: 6, 8, 12 sau 16 cutii de pranz (200x250 mm fiecare).

cod	mm	lei
709764	480x300x(H)270	230,99
709771	540x460x(H)200	277,99
709788	700x290x(H)350	301,99
709795	550x460x(H)360	316,99





267264

### CUTIT ELECTRIC PENTRU KEBAB

- Ideal pentru felierea oricarui tip de carne prajita precum; kebab, shaorma, gyros etc.
- Disc mare de taiere, neted  $\varnothing 80$  mm cu protectie din otel inoxidabil.
- Capacul lamei asigura siguranta in timpul taierii.
- Include un disc suplimentar de taiere  $\varnothing 80$  mm.
- Lama se roteste la 8000 RPM.
- Maner din aluminiu cu cablu de alimentare de 2,7 m.
- Protectie la intrare: IPX4.
- Adaptor cu bec indicator.
- Piatra de ascutit pentru lame, suportul cutitelor si o surubelnita sunt incluse.

cod	V	W	mm	lei
267264	230	80	232x120x(H)140	1119,00



267240

### CUTIT ELECTRIC KEBAB

- Pentru feliere kebab, shaorma, gyros, etc.
- 2 lame din otel inoxidabil  $\varnothing 100$  mm - 1 lama neteda si 1 lama striata.
- Lama se roteste cu 2600 rpm si poate felia pana la 60 kg/h.
- Grosime taiere reglabila, de la 0 mm pana la 8 mm.
- Protectie lama din otel inoxidabil care ofera siguranta in manevrare.
- Manerul si carcasa motorului din material anti-alunecare.
- Comutator ON/OFF integrat in carcasa.
- Protectie la supraincercare cu buton resetare.
- Sistem ascutire inclus.
- Greutate 1 kg.

cod	V	W	mm	lei
267240	230	80	262x134x(H)189	529,99



267226

### CUTIT ELECTRIC KEBAB PROFI LINE

- Conceput pentru industria restaurantelor pentru taierea tuturor tipurilor de carne prajita kebab
- Lama din otel inoxidabil
- Setul include: ascutitor lama, lama suplimentara, cablu de alimentare
- Reglare usoara a grosimii feliei
- Aparatoare lama pentru siguranta in operare
- Diametru lama: 80 mm
- Viteza: 5000 rpm
- Greutate: 1 kg

cod	V	W	mm	lei
267226	230	90	215x115x(H)106	2899,00



267257

### CUTIT ELECTRIC KEBAB, FARA FIR

- Pentru feliere kebab, shaorma, gyros, etc.
- 2 lame din otel inoxidabil  $\varnothing 100$  mm - 1 lama neteda si 1 lama striata
- Lama se roteste cu 2600 rpm si poate felia pana la 60 kg/h
- Grosime taiere reglabila, de la 0 mm pana la 8 mm
- Protectia lama din otel inoxidabil ofera siguranta in manevrare
- Manerul si carcasa motorului din material anti-alunecare
- Comutator ON/OFF integrat in carcasa
- Incarcator cu indicator luminos (rosu si verde) pentru nivel baterie
- 2 acumulatori cu capacitate 2000 mAh fiecare, inclusi
- Sistem ascutire inclus
- Greutate 1,3 kg

cod	V	W	mm	lei
267257	230	80	155x127x(H)202	769,99





## KEBAB GRILL SI CUTIT KEBAB

- Functioneaza cu gaze naturale, cu optiunea de a trece la gaz imbuteliat.
- Echipat cu o supapa de siguranta.
- Reglarea distantei este diferita de elementele de incalzire.
- 2 scuturi termice din otel inoxidabil, deschise prin leagan (dreapta si stanga) cu posibilitatea de a le desuruba.

- Carcasa din otel inoxidabil.
- Capacul arzatorului din otel inoxidabil AISI-310.
- Este necesara conexiunea la retea electrica.

S.S.  
stainless steel



Motorul se poate roti in sens orar sau antiorar

Ecranele de reflexie ajuta la economisirea de pana la 30% din gaz



143087

Ascundere ecrane reflectie

3 puterea zonelor de incalzire 9,75 kW

Tava de scurgere detasabila



226001

Echipate cu 4 arzatoare

## KEBAB GRILL PE GAZ PROFI LINE

- 3 arzatoare cu putere totala 9,75 kW.
- Lungime gratar: 725 mm, capacitate de pana la 40 kg, dimensiuni maxime rulou carne  $\phi 400 \times (H) 510$  mm.
- Dimensiuni, inclusiv tava pentru picaturi si pentru carne: 550x700x(H)960 mm.
- Greutate: 25 kg.

cod	kW(HS)	mm	lei
143087	9.75	470x550x(H)960	3699,00

## KEBAB GRILL GAZ PROFI LINE

- Se racordeaza la gaz natural dar si la gaz propan, pentru care detine convertor
- Echipat cu termocuplu
- Distanța tijeii fata de elementul de incalzire poate fi ajustata
- Putere arzatoare 12 kW
- Livrat cu panouri reflectorizante
- Lungime tija 900 mm
- Se poate folosi pentru o cantitate de carne de pana la 80 kg
- Greutate 30 kg

cod	kW(HS)	mm	lei
226001	13	735x745x(H)1110	4199,00

Motorul din partea de sus se poate roti in sensul acelor de ceasornic si in sens invers acelor de ceasornic pentru

**S.S.**  
stainless steel

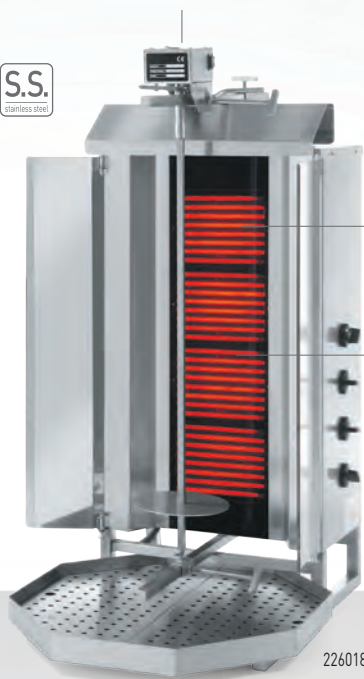

Sticla ROBAX

4 pentru zonele de incalzire  
cu o putere de 7,2 kW

226018

### KEBAB GRILL ELECTRIC PROFI LINE

- Carcasa din otel inoxidabil
- 4 zone de incalzire sigilate in sticla ROBAX, aprox. 1,8 kW fiecare, independente
- Fiecare zona cu un comutator si 5 niveluri de caldura: 0-1-2-3-MAX
- Motor reversibil montat deasupra
- Reglarea distantei tijei fata de elementele de incalzire
- 2 ecrane de reflexie basculante din otel inoxidabil: 155x(H)765 mm
- Dimensiuni tija: 12x12x(H)890 mm, lungime utila: 650 mm
- Diametrul placii: ø180 mm
- Greutate carne de la 40 la 60 kg, dimensiuni maxime carne: ø300x(H)650 mm
- Tava de picurare detasabila
- Greutate: 30 kg

cod	V	W	mm	lei
226018	400	7200	550x700x(H)1120	5649,00

**XL**  
→ |545 mm| ←



3000 W  
230 V

263624

### GRATAR DE CONTACT „PANINI” XL

- Camere incalzite cu 3 incalzitoare eficiente: sus, jos si mijloc (comun pentru ambele camere)

cod	V	W	mm	lei
263624	230	2700	548x464x(H)231	1369,00



## ROTISOR CU GAZ, PENTRU PUI

- Carcasa din otel inoxidabil.
- Usa batanta din sticla calita.
- Usa din dreapta se deschide impreuna cu o parte a carcasei din dreapta pentru a facilita introducerea gratarelor.
- Lungimea tijeii cu maner: 950 mm, lungimea utilizabila a tijeii: 740 mm.
- Sectiune transversala 12x12 mm.
- Include duze de gaz imbuteliate GPL.
- Camera interioara iluminata.



226070



cod	226063	226070	226087
capacitate	8-10 pui	12-15 pui	16-20 pui
tije rotative	2	3	4
dimensiuni	1150x472x(H)605 mm	1150x472x(H)795 mm	1150x472x(H)981 mm
zone de incalzire	2	3	4
consum gaz	0,98 m <sup>3</sup> /h	1,46 m <sup>3</sup> /h	1,96 m <sup>3</sup> /h
putere	9,4 kW [Hs]	14,1 kW [Hs]	18,8 kW [Hs]
greutate	65 kg	85 kg	100 kg
lei	<b>8299,00</b>	<b>9699,00</b>	<b>11099,00</b>

Sistem de deschidere a usii pentru a facilita scoaterea gratarelor



Zone de incalzire controlate independent



Tava de scurgere detasabila

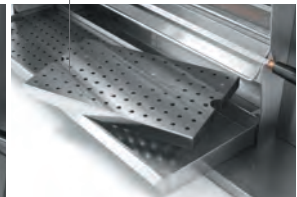

## ROTISOR ELECTRIC PENTRU PUI



- Carcasa si camera fabricate din otel inoxidabil.
- Usi din sticla calita.
- Manerele usilor sunt fabricate din rasina sintetica rezistenta la caldura.
- Usa din partea dreapta se deschide cu partea dreapta a carcasei pentru o descarcare usoara.
- Prevazut cu lumina pentru camera.
- Puterea poate fi controlata independent pentru fiecare incalzitor.

- Tava detasabila pentru colectarea grasimilor si reziduurilor.
- Lungime tepusa si maner: 950 mm; lungime tepusa utilizabila: 740 mm.
- Diametru: 12x12 mm.
- Accesorii incluse: tepi pentru frigere, suruburi cu cap striat, distantiere, cheie pentru tepuse.

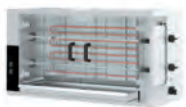
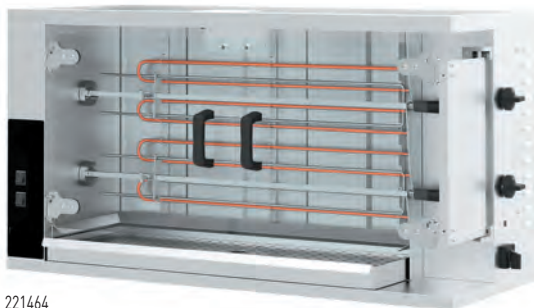

cod	221464	221471	221488
capacitate	8-10 pui	16-20 pui	24-30 pui
tije rotative	2	4	6
dimensiuni	1150x550x(H)610 mm	1150x550x(H)980 mm	1150x550x(H)1520 mm
putere	6 kW	12 kW	18 kW
tensiune	400 V	400 V	400 V
lei	6899,00	9499,00	12599,00





224830



Vezi filmul

**APARAT PASTE**

- Perfect pentru prepararea pastelor proaspete (latime maxima 140 mm)
- Grosime aluat ajustabila in 7 pasi, de la 0,2 mm la 2,5 mm
- 3 role/cutite din aliaj de aluminiu: rola aluat, cutit tagliatelle si cutit fettuccine
- Include o manivela si o clema pentru prindere de masa

cod	mm	lei
224830	210x193x(H)135	129,99

**APARAT ELECTRIC PASTE**

- Perfect pentru prepararea pastelor proaspete (latime maxima 170 mm)
- Capac echipat cu buton de siguranta
- Grosime aluat ajustabila in 7 pasi, de la 0,2 mm la 2,5 mm
- 3 role/cutite: rola aluat, cutit tagliatelle (6,25 mm) si cutit fettuccine (2 mm)

cod	V	W	mm	lei
224847	230	70	256x213x(H)232	853,99



Vezi filmul



224847



226407



Vezi filmul

### APARAT PASTE KITCHEN LINE

- Perfect pentru prepararea pastelor proaspete (latime maxima: 140 mm).
- Potrivit pentru montare pe masa, operare manuala.
- Buton pentru reglarea grosimii pastelor - de la 0,2 pana la 2,2 mm.
- Lama dubla - se pot prepara doua tipuri de paste: tagliatelle 2 mm si fettuccine 6,5 mm.

cod	mm	lei
226407	180x130x(H)205	388,99



226414



### APARAT ELECTRIC PASTE KITCHEN LINE

- Perfect pentru prepararea pastelor proaspete (latime maxima: 140 mm).
- Buton pentru reglarea grosimii pastelor - de la 0,2 pana la 2,2 mm.
- Lama dubla - se pot prepara doua tipuri de paste: tagliatelle 2 mm si fettuccine 6,5 mm.
- Potrivit pentru montarea pe masa si functionarea manuala.

cod	V	W	mm	lei
226414	230	80	200x185x(H)160	855,99



Rola din otel  
inoxidabil



Vezi filmul



### APARAT RAZUIRE BRANZETURI

- Capacitate: 30 kg/h
- Corp stabil, functionabil si practic
- In ciuda dimensiunilor mici are performante excelente
- Ideala pentru parmezan si alte branzeturi tari
- Motorul este protejat impotriva supraincarcarii
- Echipata cu un recipient de 1,3 lt
- Viteza 1400 rpm
- Greutate 8 kg
- Diametrul rolei Ø110x60 mm
- Greutate 8 kg

cod	-	V	W	mm	lei
226827	30 kg/h	230	380	292x226x(H)302	1679,00



226827



18/8  
stainless steel

## MASINA PENTRU PASTE

- Pentru utilizare in gastronomie profesionala
- Pentru framantarea si extrudarea pastelor sub diverse forme din aluat proaspat
- Carcasa, bolul, agitatoarele si capacul sunt realizate din otel inoxidabil AISI 304
- Un panou de control electronic permite trecerea operatiunii de la framantarea aluatului la extrudarea formelor de paste gata preparate
- Capacul cu grila permite adaugarea ingredientelor in siguranta si in timp ce dispozitivul functioneaza
- Microcomutatorul opreste automat masina atunci cand capacul este deschis
- Bolul detasabil si agitatoarele se pot spala in masina de spalat vase
- Capacitate de productie: 8 kg/h
- Sarcina maxima de aluat per ciclu: 2 kg
- Greutate: 26,5 kg
- Filtrele de extrudare pentru paste masurand ø57 mm comandate separat



201619

cod	V	W	mm	lei
201619	230	370	300x550x(H)540	8299,00

PIZZA, PASTE, KEBAB



**NOU**



229330

## CUTIT ELECTRIC PENTRU TAITEI

- Viteza reglabila: 0 la 80 rpm.

cod	mm	lei
229330	240x110x(H)70	2389,00



### MATRITA PENTRU EXTRUDER - BIGOLI

- Fabricat din alama
- 22 orificii cu  $\varnothing 3$  mm fiecare

cod	lei
229347	351,99



### MATRITA PENTRU EXTRUDER - PAPPARDELLE

- Fabricat din alama
- 5 orificii de 16x1 mm fiecare

cod	lei
229385	351,99



### MATRITA PENTRU EXTRUDER - FETTUCINE

- Fabricat din alama
- 15 orificii de 8x1 mm fiecare

cod	lei
229354	351,99



### MATRITA PENTRU EXTRUDER - SFOGLIA

- Fabricat din alama
- 1 orificiu pentru producerea unei foi intregi de aluat; are 155 mm lungime si 1-4 mm grosime

cod	lei
229392	419,99



### MATRITA PENTRU EXTRUDER - FUSILLI

- Fabricat din alama
- 5 orificii de  $\varnothing 9$  mm fiecare

cod	lei
229361	351,99



### MATRITA PENTRU EXTRUDER - CAPELLI D'ANGELO

- Fabricat din alama
- 22 orificii cu  $\varnothing 1$  mm fiecare

cod	lei
229408	351,99



### MATRITA PENTRU EXTRUDER - CASARECCE

- Fabricat din alama
- 5 gauri in forma de S cu dimensiunea de 9x5 mm fiecare

cod	lei
229378	351,99



### MATRITA PENTRU EXTRUDER - GNOCCHI

- Fabricat din alama
- 1 orificiu de  $\varnothing 12$  mm

cod	lei
229415	351,99



### MATRITA PENTRU EXTRUDER - SPAGHETTI

- Fabricat din alama
- 22 orificii cu  $\varnothing 2$  mm fiecare

cod	lei
229484	351,99

975534



### FORMA DE RAVIOLI

- O forma pentru ravioli clasic
- Matrita din aluminiu turnat sub presiune
- Baza din otel vopsit
- Pe picioarele de cauciu
- 36 matrite 30x30x(H)8 mm
- Rola de lemn inclusa.

cod	mm	lei
975534	320x137x(H)18	112,99

975541



### FORMA DE RAVIOLI CHEF

- Forma pentru ravioli rotund
- Matrita din aluminiu turnat sub presiune
- Baza din otel vopsit
- Pe picioarele de cauciu
- 12 matrite 52x52x(H)12 mm
- Diametrul matritei 39 mm
- Rola de lemn inclusa.

cod	mm	lei
975541	335x114x(H)22	112,99

**NOU****PRESA PENTRU GALUSTE**

- Pentru prepararea usoara a 5 galuste simultan.
- Corp realizat din otel inoxidabil cu finisaj mat.
- Maner realizat din aluminiu.
- Cu balamale realizate din otel inoxidabil care conecteaza 2 parti ale formei.
- Suprafata de lucru finisata cu un strat antiaderent - pentru indepartarea fara efort a galustelor preparate.
- Manipulati pe intreaga lungime a formularului - pentru presiune uniforma si functionare convenabila.
- Cu 4 picioare anti-alunecare din cauciu.

- Grosimea maxima si diametrul unei galuste: 21 mm, ø80 mm.
- Latimea marginii unei galuste: 8 mm.
- Dimensiunile aparatului de galuste deschis: 470x245x80 mm.
- Nu poate fi spalat in masina de spalat vase.
- ATENTIE: pentru a preveni deteriorarea invelisului, nu utilizati aparatul pentru galuste fara aluat in interior. Nu spalati stratul de acoperire cu agenti de curatare puternici si bureti aspri.

cod	mm	lei
230107	470x140x(H)95	1639,00

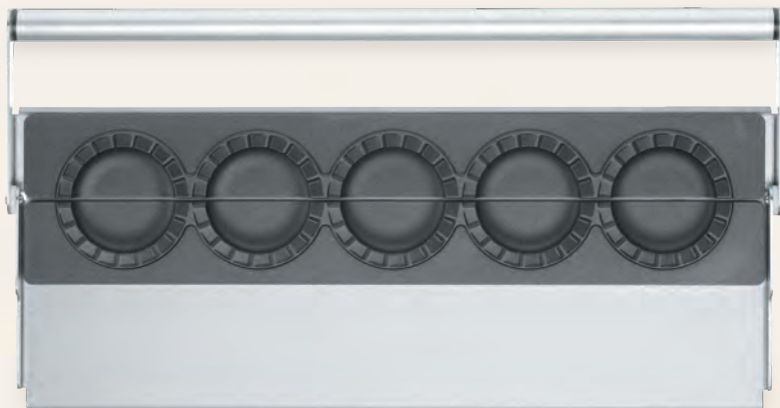

## APARAT PENTRU PASTE

- Pentru prepararea pastelor, galustelor si legumelor.
- Partea superioara a carcasei este fabricata din otel inoxidabil AISI 304.
- Alte parti ale carcasei (fara blatul de lucru) fabricate din otel inoxidabil AISI 430.
- Recipient realizat din otel inoxidabil AISI 316, cu o capacitate de 10 l.
- Elementul de incalzire se afla in partea inferioara a camerei, cu un capac.
- Conexiune directa la apa.
- Supapa pentru apa proaspata la panoul de comanda frontal.
- Reglare temperatura cu un cadran in interval: de la 30°C la 120°C.
- Indicator luminos care informeaza cu privire la atingerea temperaturii setate.
- Duza detasabila pentru apa uzata.

18/0  
stainless steel

18/10  
stainless steel

outdoor

- Suport pentru cosuri destinate drenarii continutului.
- Blocare mecanica pentru prevenirea deschiderii accidentale a robinetului de golire.
- Protectie la supraincalzire cu resetare pe panoul de comanda frontal.
- Picioare anti-alunecare.
- Inclus: 2 cosuri de 100x292x(H)158 mm si un capac.
- Aparatul este livrat fara setcher.

**NOU**

238899



Cos si capac incluse

## APARAT PENTRU PASTE SI GALUSTE

cod	V	W	mm	lei
238899	230	3500	330x600x(H)380	5509,00



238844

## APARAT PENTRU PASTE SI GALUSTE, DE SINE STATATOR

- Aparat de sine statator - pe un suport.
- Stand inchis pe 3 laturi, fabricat din otel inoxidabil AISI 430.
- Dimensiunile interioare ale suportului: 325x545x(H)437 mm.
- Picioare reglabile in interval: 100-160 mm.

cod	V	W	mm	lei
238844	230	3500	330x600x(H)907	6049,00

## COS

cod	-	mm	lei
943465	Cos pentru aparat paste 238899	100x292x(H)158	499,99

S.S.  
stainless steel



943465

## DULAPURI FRIGORIFICE REFRIGERARE / CONGELARE PROFI LINE | SERIA 800 ARKTIC



- Carcasa interioara si exterioara sunt realizate din otel inoxidabil de inalta calitate, cu exceptia capacului din spate exterior care este fabricat din otel zincat.
- Usi dotate cu maner confortabil
- Racire cu aer si auto-dezghetare, compresor amplasat deasupra camerei.
- Izolatie de spuma poliuretunica de grosime de 60 mm.

- Cu rafturi reglabile, se potriveste cu containere pana la GN 2/1.
- Afisaj digital si termostat electronic.
- Montat cu 4 roti, dintre care 2 sunt roti pivotante
- Clasa climatica: 5.



Vezi filmul

232118  
232132



### RAFT PENTRU RACIREA SI CONGELAREA DULAPURILOR GN 2/1, ALB

- Raft din otel, acoperit cu polietilena alba, cablat.
- Dimensiuni - GN 2/1.
- Greutate neta: 2,4 kg.

cod	mm	lei
801888	530x650	89,99

Camera si carcasa exterioara fabricate din otel inoxidabil

232125  
232149



ECHIPAMENTE FRIGORIFICE



	<b>B</b> A E	<b>C</b> A E	<b>B</b> A E	<b>C</b> A E
tip	refrigerare, 1-usa	congelare, 1-usa	refrigerare, 2-usi	congelare, 2-usi
cod	232118	232132	232125	232149
capacitate	670 l	670 l	1300 l	1300 l
dimensiuni	730x800x(H)2096 mm	730x800x(H)2096 mm	1314x800x(H)2082 mm	1314x800x(H)2082 mm
dim. interioare	610x635x(H)1540 mm	610x635x(H)1540 mm	1194x635x(H)1540 mm	1194x635x(H)1540 mm
temperatura	0/8°C	-22/-17°C	0/8°C	-22/-17°C
refrigerant	R600a (110 g)	R290 (120 g)	R600a (140 g)	R290 (150 g)
clasa energetica	B	C	B	C
rafturi	4 x GN 2/1 (650x530 mm)*	4 x GN 2/1 (650x530 mm)*	4+4 x GN 2/1 (650x530 mm)*	4+4 x GN 2/1 (650x530 mm)*
consum mediu zilnic	1,26 kWh	4,99 kWh	2,01 kWh	8,19 kWh
putere/tensiune	220 W/230 V	600 W/230 V	350 W/230 V	980 W/230 V
greutate	107 kg	115 kg	171 kg	177 kg
lei	<b>6049,00</b>	<b>6819,00</b>	<b>8999,00</b>	<b>9759,00</b>

\* Capacitate maxima admisa a raftului este de aproximativ 40 kg (cu o distribuire uniforma a greutatii)

Prevazut cu roti



Racire dinamica forzata



Usa cu autoincuietorea



## DULAPURI FRIGORIFICE REFRIGERARE / CONGELARE PROFI LINE | SERIA 700 ARKTIC

**arktic**

S.S.  
stainless steel

cooling

- Carcasa interioara si exteriora sunt realizate din otel inoxidabil de inalta calitate, cu exceptia capacului din spate exterior care este fabricat din otel zincat.
- Usi dotate cu maner confortabil.
- Racire cu aer rece cu auto-dezghetare, compresor amplasat deasupra camerei.

- Izolatie de spuma poliuretunica de grosime de 50 mm.
- Cu rafturi reglabile, se potriveste cu containere pana la GN 1/1.
- Afisaj digital si termostat electronic.
- Montat cu 4 roti, dintre care 2 sunt roti pivotante.
- Clasa climatica: SN-ST.

233108  
233115



233122  
233139



Camera si carcasa exteriora  
fabricate din otel inoxidabil



tip	refrigerare, 1-usa	congelare, 1-usa	refrigerare, 2-usi	congelare, 2-usi
cod	233108	233115	233122	233139
capacitate	410 l	440 l	900 l	900 l
dimensiuni	600x740x(H)1950 mm	600x740x(H)1950 mm	1200x740x(H)1950 mm	1200x740x(H)1950 mm
dim. interioare	500x540x(H)1380 mm	500x540x(H)1380 mm	1100x540x(H)1380 mm	1100x540x(H)1380 mm
temperatura	0/8°C	-22/-17°C	0/8°C	-22/-17°C
compresor	EMT65HLT putere 1/4 KM	NE2124Z putere 1/2 KM	EG AS100HLR putere 1/3 KM	NEK2150GK putere 3/4 KM
refrigerant	R600a (80 g)	R290 (90 g)	R600a (130 g)	R290 (150 g)
clasa energetica	C	D	C	D
clasa climatica	5	4	5	4
rafturi	4 x 485x525 mm*	4 x 485x525 mm*	4+4 x 525x530 mm*	4+4 x 525x530 mm*
consum mediu zilnic	1,43 kWh	5,78 kWh	2,18 kWh	9,17 kWh
putere/tensiune	290 W/230 V	600 W/230 V	450 W/230 V	750 W/230 V
greutate	82 kg	82 kg	132 kg	132 kg
lei	<b>5149,00</b>	<b>6349,00</b>	<b>7399,00</b>	<b>7899,00</b>

\* Capacitate maxima admisa a raftului este de aproximativ 40 kg (cu o distribuire uniforma a greutatii)

Controler electronic pentru temperatura

Camera fabricata din otel inoxidabil

Maner ergonomic



## DULAPURI FRIGORIFICE REFRIGERARE / CONGELARE PROFI LINE 420+420 L I 890+420 L

**arktic**  
PROFESIONALI IN FRIGERARE

**S.S.**  
stainless steel

cooling

- Interiorul și exteriorul sunt fabricate din oțel inoxidabil de calitate înaltă, exceptând partea din spate exterior care este realizată din oțel galvanizat
- Racire forțată
- Izolație de 55 mm grosime (material: C5H10)
- Ecran digital și termostat electronic

- Compresor EMBRACO™
- Evaporare automată a condensului
- Clasa climatică: 4
- Usa cu închidere automată, care se deschide pe partea stângă
- Echizat cu 4 roți din care 2 sunt roți pivotante

Camera și carcasa exterioră fabricate din oțel inoxidabil



233146

**D**  
A  
E



233153

**D**  
A  
E



tip	refrigerare-congelare, 2-usi	refrigerare-congelare, 3-usi
cod	233146	233153
capacitate	420+420 l	890+420 l
dimensiuni	1200x740x(H)1950 mm	1800x740x(H)1950 mm
dim. interioare	friger - 550x540x(H)1380 mm congelator - 550x540x(H)1380 mm	friger - 1100x540x(H)1380 mm congelator - 600x540x(H)1380 mm
temperatura	0/8°C, -17/-22°C	0/8°C, -17/-22°C
compresor	friger - EMT65HLR putere 1/4 KM congelator - NE2134Z putere 1/2 KM	2x NE2134Z putere 1/2 KM fiecare
refrigerant	friger - R600a (80 g) congelator - R290 (90 g)	friger - R600a (130 g) congelator - R290 (90 g)
clasa energetică	D	D
rafturi	4+4 x 510x525 mm*	friger - 8x 525x530 mm congelator - 4x 510x525 mm
consum mediu zilnic	8,22 kWh	9,32 kWh
putere/tensiune	870 W/230 V	1150 W/230 V
greutate	158 kg	207 kg
lei	<b>9549,00</b>	<b>11199,00</b>

Racire dinamică forțată

Usa cu încuietore

\* Capacitatea maximă admisă pe raft este de aproximativ 40 kg (cu o distribuție uniformă a greutății)



## MESE RECI PROFI LINE

- Corp interior si exterior realizat din otel inoxidabil AISI 201 de inalta calitate (peretele exterior posterior din otel zincat).
- Racire fortata, filtru de polen.
- Grosimea izolatiei: 60 mm (material: C5H10).
- Afisaj digital, termostat electronic.
- Unitate de racire EMBRACO.
- Evaporarea automata a condensului.

**arktic**  
PROFESIONALE

S.S.  
stainless steel

cooling

- Clasa climatica: 5 (232040, 232057) sau 4 (232064, 232699).
- Usa cu inchidere automata.
- Maner profilat convenabil pentru deschiderea usii.
- 4 picioare din otel inoxidabil reglabile care nu se rasucesc.
- Marginea 40 mm.



Camera si carcasa exteriora fabricate din otel inoxidabil



232040  
232064

4 RAFTURI  
CU GHIDAJE  
GRATIS!



233764



232057  
232699

6 RAFTURI  
CU GHIDAJE  
GRATIS!

\* Capacitate maxima admisa a raftului este de aproximativ 40 kg (cu o distribuire uniforma a greutatii)

	<b>A</b> A G	<b>B</b> A G	<b>C</b> A G	<b>A</b> A G	<b>C</b> A G
tip	refrigerare, 2-usi	refrigerare, 4-usi	congelare, 2-usi	refrigerare, 3-usi	congelare, 3-usi
cod	232040	233764	232064	232057	232699
capacitate	280 l	280 l	280 l	420 l	420 l
dimensiuni	1360x700x(H)850 mm	1360x700x(H)850 mm	1360x700x(H)850 mm	1795x700x(H)850 mm	1795x700x(H)850 mm
dim. interioare	822x570x(H)580 mm	822x570x(H)580 mm	822x570x(H)580 mm	1257x570(H)580 mm	1257x570(H)580 mm
temperatura	0/8°C	0/8°C	-22/-17°C	0/8°C	-22/-17°C
compresor	EMT65HLR putere 1/4 KM	EMT65HLR putere 1/4 KM	EGU130HLR putere 1/2 KM	EGAS100HLR putere 1/3 KM	NEK2140Z putere 2/3 KM
refrigerant	R600a (120 g)	R600a (120 g)	R290 (140 g)	R290 (130 g)	R290 (140 g)
clasa energetica	A	B	C	A	C
rafturi	2+2 x GN 1/1*	4 szuffaly	2+2 x GN 1/1*	2+2+2 x GN 1/1*	2+2+2 x GN 1/1*
consum mediu zilnic	1,34 kWh	1,34 kWh	3,97 kWh	1,73 kWh	5,09 kWh
putere/tensiune	250 W/230 V	250 W/230 V	600 W/230 V	400 W/230 V	600 W/230 V
greutate	95 kg	95 kg	95 kg	120 kg	120 kg
lei	<b>5829,00</b>	<b>8599,00</b>	<b>7229,00</b>	<b>7399,00</b>	<b>7899,00</b>

## DULAPURI FRIGORIFICE REFRIGERARE / CONGELARE KITCHEN LINE

**arktic**   
PROFESIONALE COMMERCIALE

**S.S.**   
stainless steel cooling

- Carcasa interioara si cea exteriora fabricate din otel inoxidabil de inalta calitate, exceptand partea din spate a carcasei care este fabricata din otel galvanizat
- Racire forzata, compresorul in partea de jos
- Cu filtru particule
- Compresor EMBRACO



- Camera racire potrivita pentru GN 2/1
- Izolatie din spuma poliuretanică, grosime 60 mm
- Usi cu sistem inchidere
- Manere confortabile, curbate
- 4 picioare din otel inoxidabil, ajustabile
- Display digital si termostat electronic



Vezi filmul

232729  
232514



### RAFT PENTRU RACIREA SI CONGELAREA DULAPURILOR GN 2/1, ALB

- Raft din otel, acoperit cu polietilena alba, cablat.
- Dimensiune - GN 2/1.
- Greutate neta: 2,4 kg.

cod	mm	lei
801888	530x650	89,99

Camera si carcasa exteriora fabricate din otel inoxidabil



232736

ECHIPAMENTE FRIGORIFICE



tip	refrigerare, 1-usa	congelare, 1-usa	refrigerare, 2-usi
cod	232729	232514	232736
capacitate	580 l	580 l	1300 l
dimensiuni	685x800x(H)2100 mm	685x800x(H)2100 mm	1382x800x(H)2100 mm
dim. interioare	565x640x(H)1525 mm	565x640x(H)1525 mm	1262x640x(H)1525 mm
temperatura	-5/5°C	-18/-12°C	-5/5°C
refrigerant	R600a (120 g)	R290 (120 g)	R290 (110 g)
clasa energetica	D	D	D
rafturi	4 x GN 2/1	4 x GN 2/1	4+4 x GN 2/1
consum mediu zilnic	2,5 kWh	6,79 kWh	3,77 kWh
putere/tensiune	350 W/230 V	500 W/230 V	320 W/230 V
greutate	110 kg	120 kg	180 kg
lei	4909,00	5299,00	7049,00

Controler electronic pentru temperatura



Racire statica asistata de ventilator



Usa cu incuietorea



## FRIGIDER SI CONGELATOR KITCHEN LINE | SERIA 600

arktic

S.S.  
stainless steel

cooling

- Carcasa interioara si exterioara sunt realizate din otel inoxidabil de inalta calitate
- Usi cu inchidere automata cu manere confortabile.
- Suprafata de lucru este prevazuta cu o creasta de 40 mm in spate.
- Racire cu aer comprimat cu auto-dezghetare, compresor amplasat sub camera.
- Izolatie de spuma poliuretunica de grosime de 50 mm.
- Cu rafturi reglabile.
- Afisaj digital si termostat electronic.
- Cu 4 picioare reglabile din otel inoxidabil.
- Clasa climatica: 5 (233344, 233382), 4 (233351, 233399).



233344  
233351

233382  
233399

B A G

C A G

B A G

C A G

tip	refrigerare, 2-usi	congelare, 2-usi	refrigerare, 3-usi	congelare, 3-usi
cod	233344	233351	233382	233399
capacitate	166 l	166 l	291 l	291 l
dimensiuni	1200x600x(H)800 mm	1200x600x(H)800 mm	1800x600x(H)800 mm	1800x600x(H)800 mm
dim. interioare	800x480x(H)580 mm	800x480x(H)580 mm	1400x480x(H)580 mm	1400x480x(H)580 mm
temperatura	0/8°C	-22/-17°C	0/8°C	-22/-17°C
compresor	EMT65HLR putere 1/4 KM	NE2134Z-263CA putere 1/2 KM	FF110HAK putere 1/3 KM	NEK2140GZ-269GA putere 1/2 KM
refrigerant	R600a (100 g)	R290 (90 g)	R600a (100 g)	R290 (90 g)
clasa energetica	B	C	B	C
clasa climatica	5	4	5	4
rafturi	1+1 x 390x428 mm*	1+1 x 390x428 mm*	2x 430x428 mm + 1x 490x428 mm*	2x 430x428 mm + 1x 490x428 mm*
consum mediu zilnic	2,06 kWh	4,5 kWh	2,36 kWh	5,48 kWh
putere/tensiune	270 W/230 V	550 W/230 V	270 W/230 V	550 W/230 V
greutate	74 kg	74 kg	100 kg	100 kg
lei	5209,00	5539,00	5999,00	6899,00

\* Capacitate maxima admisa a raftului este de aproximativ 40 kg (cu o distribuire uniforma a greutatii)

Controler electronic pentru temperatura



Racire forzata cu aer



Plasare ajustabila pe rafturi



## MESE FRIGORIFICE CU BLAT DE LUCRU DIN OTEL INOXIDABIL



- Carcasa interioara si exteriora sunt realizate din otel inoxidabil AISI 201 de inalta calitate.
- Blatul mesei este realizat din otel inoxidabil AISI 201, umplut cu PAL pentru a-si consolida structura.
- Racire statica asistata de ventilator intern.
- Clasa climatica: 4.
- Versiunile cu sertare sunt perfecte pentru a amplasa recipiente GN 1/1, 2x 1/2 sau 3x 1/3, in ele.



Camera si carcasa exteriora fabricate din otel inoxidabil



236154



236130



236147

tip	refrigerare, 4-sertare	refrigerare, 2-usi	refrigerare, 3-usi
cod	236154	236130	236147
capacitate	247 l	247 l	368 l
dimensiuni	900x700x(H)850 mm	900x700x(H)850 mm	1365x700x(H)850 mm
dim. interioare	830x595x(H)455 mm	830x595x(H)455 mm	1295x595x(H)455 mm
temperatura	2/8°C	2/8°C	2/8°C
refrigerant	R290 (55 g)	R290 (55 g)	R290 (60 g)
rafturi	4 sertare	1+1 x 333x560 mm	1+1+1 x 333x560 mm
consum mediu zilnic	3,39 kWh	3,39 kWh	4,00 kWh
putere/tensiune	143 W/230 V	143 W/230 V	152 W/230 V
greutate	72 kg	72 kg	110 kg
lei	<b>7119,00</b>	<b>3099,00</b>	<b>6199,00</b>

Controler electronic pentru temperatura



Rafturi din otel, acoperite cu plastic, tip gratar



Manere aliniate la nivel cu suprafata usii



## MESE FRIFORIFICE REFRIGERARE CU SUPRASTRUCTURA DIN OTEL INOXIDABIL SI BLAT DE GRANIT

**arktic**  
TECHNOLOGIA DE REFRIGERARE

**S.S.**  
stainless steel

cooling

- Agent frigorific R290 ecologic.
- Corp interior si exterior din otel inoxidabil AISI 201 de inalta calitate.
- Afisaj digital, termostat electronic.
- Racire statica asistata de ventilator intern.

- Clasa climatica: 4.
- Spatiu in partea de sus pentru containere GN 1/6.
- Blat de lucru din granit.
- Maner ergonomic pentru a deschide usa.



236208

Camera si carcasa exteriora fabricate din otel inoxidabil



236215

tip	refrigerare, 2-usi	refrigerare, 3-usi
cod	236208	236215
capacitate	247 l	368 l
dimensiuni	900x700x(H)1070 mm	1365x700x(H)1070 mm
dim. interioare	830x595x(H)455 mm	1295x595x(H)455 mm
spatiu de lucru	5x GN 1/6 - (H)150 mm*	8x GN 1/6 - (H)150 mm*
temperatura	2/8°C	2/8°C
refrigerant	R290 (55 g)	R290 (60 g)
rafturi	1+1 x 333x560 mm	1+1+1 x 333x560 mm
consum mediu zilnic	3,5 kWh	4,2 kWh
putere/tensiune	145 W/230 V	156 W/230 V
greutate	92 kg	120 kg
lei	<b>3789,00</b>	<b>5979,00</b>

\* Capacitate maxima admisa a raftului este de aproximativ 40 kg (cu o distribuire uniforma a greutatii)

Controler electronic pentru temperatura

Rafturi din otel, acoperite cu plastic, tip gratar

Suprafata de lucru confectionata din granit



## MESE FRIGORIFICE REFRIGERARE PIZZA

- Carcasa interioara si exteriora sunt realizate din otel inoxidabil de inalta calitate, cu blat de lucru din granit.
- Usile sunt prevazute cu manere confortabile.
- Racire cu aer rece cu dezghetare automata, compresor amplasat sub camera.
- Cu rafturi reglabile, se potriveste cu containere pana la GN 1/1.
- Cu blat de granit.
- Afisaj digital si termostat electronic.
- Cu 4 picioare reglabile anti-alunecare din plastic.
- Clasa climatica: SN-T.
- Toate modelele sunt livrate fara containere GN.



232842

Camera si carcasa exteriora fabricate din otel inoxidabil



232033

\* Livrat fara containere GN

## MASA PIZZA CU DOUA USI - ZONA REFRIGERATA SI 7 SERTARE - ZONA NEUTRA

- Echipat cu 7 sertare neracite de 400x620x (H) 65 mm.
- Dimensiunile camerei: 1480x670x (H) 570 mm.
- Izolatie de spuma poliuretunica de grosime de 60 mm.
- Clasa energetica: A (A+++G).
- Greutate: 367 kg.

cod	gama	V	W	mm	lei
232842	-2/8°C	230	250	2020x802x(H)1000	9179,00



## MASA REFRIGERARE PIZZA CU TREI USI SI VITRINA FRIGORIFICA TIP DISPLAY 380 L + 40 L

- Cu afisaj separat de racire, care se potriveste cu 6x GN 1/4 containere (inaltime maxima 150 mm).
- Afisajul de racire se raceste prin racirea statica.
- Dimensiunile camerei: 1295x595x (H) 500 mm.
- Izolatie de spuma poliuretunica de 35 mm grosime.
- Dimensiunile afisajului de racire: 1405x335x(H)255 mm.
- 3 rafturi (335x570 mm) incluse. Capacitate de incarcare de cate 15 kg fiecare.
- Greutate: 190+41 kg.

cod	gama	V	W	mm	lei
232033	-2/8°C	230	400	1400x700x(H)1491	8999,00



## MESE FRIGORIFICE CU CAPAC, PENTRU SALATE – SALADETTE

**arktic**  
TECHNOLOGIE DE AVANGARDE

**S.S.**  
stainless steel

**cooling**

- Carcasa interioara si exterioara din otel inoxidabil AISI 201 de inalta calitate.
- Racire statica asistata de ventilator intern.
- Afisaj digital, termostat electronic.
- Evaporarea automata a condensului.
- Clasa climatica: 4.
- Maner ergonomic pentru a deschide usa.
- 4 picioare din plastic.



236161

Camera si carcasa exterioara fabricate din otel inoxidabil



236178



236246

tip	refrigerare, 2-usi, cu capac	refrigerare, 3-usi, cu capac	refrigerare, 2-usi, lustruit, cu capac
cod	236161	236178	236246
capacitate	247 l	368 l	247 l
dimensiuni	900x700x(H)860 mm	1365x700x(H)860 mm	900x700x(H)860 mm
dim. interioare	830x595x(H)455 mm	1295x595x(H)455 mm	830x595x(H)455 mm
deschidere superioara	2x GN 1/1 + 3x GN 1/6 – (H)150 mm*	4x GN 1/1 – (H)150 mm*	2x GN 1/1 + 3x GN 1/6 – (H)150 mm*
temperatura	2/8°C	2/8°C	2/8°C
refrigerant	R290 (55 g)	R290 (60 g)	R290 (55 g)
rafturi	1+1 x 333x560 mm	1+1+1 x 333x560 mm	1+1 x 333x560 mm
consum mediu zilnic	3,52 kWh	4,1 kWh	3,52 kWh
putere/tensiune	145 W/230 V	155 W/230 V	145 W/230 V
greutate	70 kg	107 kg	70 kg
lei	<b>3119,00</b>	<b>5059,00</b>	<b>3569,00</b>



## MESE FRIGORIFICE CU TAVI GN SI CAPAC DIN STICLA

**arktic**  
PROFESIONALE



- Mesele de lucru sunt excelente pentru a prepara mancare in bistrouri sau chiar restaurante, unde clientii va pot privi preparand deserturi din bucati de fructe, salate proaspete de legume sau sandvisuri.
- Suprastructura de sticla care separa zona de preparare a alimentor de zona de servire, fara a reduce vizibilitatea.
- Raft interior din sticla care va permite sa lasati deoparte orice

produe suplimentar sau deserturi sau salate gata preparate.

- Blatul de lucru este prevazut suplimentar cu o placa de polipropilena integrata pentru taierea oricaror ingrediente suplimentar si pregatirea produselor finite in vederea clientilor.
- Camera frigorifica de sub blat este excelenta pentru depozitarea unor cantitati mari de ingrediente sau deserturi sau salate gata preparate.



Camera si carcasa exteriora fabricate din otel inoxidabil

236185



236192



Camera si carcasa exteriora fabricate din otel inoxidabil

236222



236239

tip	refrigerare, 2-usi, cu unitate superioara din sticla	refrigerare, 3-usi, cu unitate superioara din sticla	refrigerare, 2-usi, cu unitate superioara	refrigerare 3-usi, cu unitate superioara
cod	236185	236192	236222	236239
capacitate	247 l	368 l	247 l	368 l
dimensiuni	900x700x(H)1270 mm	1365x700x(H)1270 mm	900x700x(H)1990	1365x700x(H)1990
dim. interioare	830x595x(H)455 mm	1295x595x(H)455 mm	830x595x(H)455 mm	1295x595x(H)455 mm
deschidere superioara	2x GN 1/1 + 3x GN 1/6 - (H)150 mm*	4x GN 1/1 - (H)150 mm*	-	-
blat			5x GN 1/6 - (H)150 mm*	8x GN 1/6 - (H)150 mm*
temperatura	2/8°C	2/8°C	2/8°C	2/8°C
refrigerant	R290 [55 g]	R290 [60 g]	R290 [55 g]	R290 [60 g]
rafturi	1+1 x 333x560 mm	1+1+1 x 333x560 mm	1+1 x 333x560 mm	1+1+1 x 333x560 mm
consum mediu zilnic	3,52 kWh	4,10 kWh	3,39 kWh	4,00 kWh
putere/tensiune	145 W/230 V	155 W/230 V	143 W/230 V	152 W/230 V
greutate	70 kg	107 kg	72 kg	110 kg
lei	<b>4309,00</b>	<b>6159,00</b>	<b>3659,00</b>	<b>5799,00</b>



## VITRINE FRIGORIFICE TIP DISPLAY

- Carcasa interioara si cea exterioara sunt realizate din otel inoxidabil de inalta calitate.
- Racire statica cu aer cu auto-dezghetare, compresor amplasat langa camera.
- Izolatie din spuma poliuretunica de 40 mm grosime.
- Afisaj digital si termostat electronic.
- Cu 4 picioare reglabile anti-alunecare din plastic.
- Interval de temperatura:  $-2/8^{\circ}\text{C}$ .
- Clasa de clima: SN.
- Agent de racire: R600a.
- Toate modelele sunt livrate fara containere GN.

arktic



S.S.

stainless steel



cooling



232965

4x GN 1/3



232972

6x GN 1/3



232903

5x GN 1/4



232910

7x GN 1/4



232989

7x GN 1/3



232927

8x GN 1/4



232996

9x GN 1/3

## VITRINA DE PREZENTARE GN 1/4 ARKTIC

- Cu display de sticla calita
- Se potriveste cu containerile GN 1/4 cu o inaltime maxima de 150 mm

cod	-	V	W	mm	lei
232903	5x GN 1/4	230	180	1205x335x(H)460	2149,00
232910	7x GN 1/4	230	180	1505x335x(H)460	2459,00
232927	8x GN 1/4	230	180	1805x335x(H)460	2759,00

## VITRINA DE PREZENTARE GN 1/3 ARKTIC

- Cu display de sticla calita.
- Se potriveste cu containere GN 1/3 cu o inaltime maxima de 150 mm.

cod	-	V	W	mm	lei
232965	4x GN 1/3	230	180	1208x400x(H)456	2269,00
232972	6x GN 1/3	230	180	1405x420x(H)456	2459,00
232989	7x GN 1/3	230	180	1605x420x(H)460	2699,00
232996	9x GN 1/3	230	180	2005x420x(H)456	3039,00

## VITRINA DE PREZENTARE GN 1/3 ARKTIC

- Cu capac din otel inoxidabil.
- Se potriveste cu containere GN 1/3 cu o inaltime maxima de 150 mm.

cod	-	V	W	mm	lei
233986	8x GN1/3	230	180	1805x420x(H)630	2759,00
233993	9x GN1/3	230	180	2005x420x(H)630	3039,00



233948

## DULAPURI FRIGORIFICE REFRIGERARE SI CONGELARE BUDGET LINE



- Carcasa exteriora din otel lacuit alb sau otel inoxidabil (in functie de model).
- Racire statica.
- Peretele exterior si partea inferioara din spate sunt realizate din tabla zincata.
- Interior din plastic ABS.
- Izolatie groasa din spuma de ciclopentan (C5H10), in functie de model, pana la 70 mm, contribuind la o stabilitate mai mare a temperaturii in camera dulapului.
- Un termostat digital foarte precis care va permite sa determinati cu precizie temperatura de stocare.
- Rafturi reglabile cu o capacitate de incarcare de 30 kg fiecare.

- Distributie uniforma a greutateii.
- Raft suplimentar in partea de jos a camerei (doar modelele selectate - vezi tabelul).
- Control electromecanic cu afisaj electronic.
- Clasa climatica 4.
- Doua picioare frontale cu reglare mica a inaltimii pentru nivelare.
- Echipat si doua role pe spate, perfecte pentru mobilitate.
- Usi cu inchidere automata, reducand consumul de energie electrica.
- Usa standard care se poate inchide cu cheie.

ECHIPAMENTE FRIGORIFICE



236017  
236079



236031  
236093



236055

### DULAP FRIGORIFIC REFRIGERARE BUDGET LINE CU STRUCTURA DIN OTEL INOXIDABIL DE, ARKTIC

- Interval: 0/8°C

cod	litri	mm	mm int.	rafturi (mm)	clasa energetica	refrigerant	izolatie (mm)	V	W	kg	lei
236017	200	598x623x(H)838	477x482x(H)652	2x 506x415	A	R600a	60	230	124	38,50	<b>2529,00</b>
236031	400	600x701x(H)1875	460x466x(H)1643	3x 486x410 + 1x 450x210	C	R600a	70	230	157	75,50	<b>4059,00</b>
236055	600	775x769x(H)1900	635x572x(H)1643	3x 660x525 + 1x 615x190	C	R600a	70	230	193	89,00	<b>4859,00</b>

### DULAP FRIGORIFIC CONGELARE BUDGET LINE CU STRUCTURA DIN OTEL INOXIDABIL DE, ARKTIC

- Interval: -23/-18°C

cod	litri	mm	mm int.	rafturi (mm)	refrigerant	izolatie (mm)	V	W	kg	lei
236079	200	598x655x(H)838	493x477x(H)647	rafturi fixe, 2x 458x445	R600a	50	230	111	38	<b>2699,00</b>
236093	400	600x646x(H)1875	480x448x(H)1611	rafturi fixe, 6x 452x412	R290	60	230	322	75	<b>4709,00</b>
236116	600	775x710x(H)1900	645x528x(H)1643	rafturi fixe, 6x 588x496	R290	65	230	436	95,5	<b>5589,00</b>

## DULAPURI FRIGORIFICE REFRIGERARE SI CONGELARE BUDGET LINE



- Carcasa exteriora din otel lacuit alb sau otel inoxidabil (in functie de model).
- Racire statica.
- Peretele exterior si partea inferioara din spate sunt realizate din tabla zincata.
- Interior din plastic ABS.
- Izolatie groasa din spuma de ciclopentan (C5H10), in functie de model, pana la 70 mm, contribuind la o stabilitate mai mare a temperaturii in camera dulapului.
- Un termostat digital foarte precis care va permite sa determinati cu precizie temperatura de stocare.
- Rafturi reglabile cu o capacitate de incarcare de 30 kg fiecare.

- Distributie uniforma a greutateii.
- Raft suplimentar in partea de jos a camerei (doar modelele selectate - vezi tabelul).
- Control electromecanic cu afisaj electronic.
- Clasa climatica 4.
- Doua picioare frontale cu reglare mica a inaltimii pentru nivelare.
- Echipat si doua role pe spate, perfecte pentru mobilitate.
- Usi cu inchidere automata, reducand consumul de energie electrica.
- Usa standard care se poate inchide cu cheie.



236000  
236062



236024  
236086



236048

### DULAP FRIGORIFIC BUDGET LINE CARCASA DIN OTEL VOPSIT ALB, ARKTIC

- Interval: 0/8°C

cod	litri	mm	mm int.	rafturi (mm)	clasa energetica	refrigerant	izolatie (mm)	V	W	kg	lei
236000	200	598x623x(H)838	477x482x(H)652	2x 506x415	A	R600a	60	230	124	38,50	<b>2239,00</b>
236024	400	600x701x(H)1876	460x466x(H)1643	3x 486x410, 1x 450x210	C	R600a	70	230	157	69,50	<b>3619,00</b>
236048	600	775x769x(H)1900	635x572x(H)1643	3x 660x525, 1x 615x190	C	R600a	70	230	193	87,50	<b>4369,00</b>

### DULAP FRIGORIFIC DE CONGELARE, BUDGET LINE, CARCASA DIN OTEL VOPSIT, ARKTIC

- Interval: -23/-18°C

cod	litri	mm	mm int.	rafturi (mm)	refrigerant	izolatie (mm)	V	W	kg	lei
236062	200	598x655x(H)838	493x477x(H)647	rafturi fixe, 2x 458x445	R600a	50	230	111	37,50	<b>2409,00</b>
236086	400	600x646x(H)1875	480x448x(H)1611	rafturi fixe, 6x 425x412	R290	60	230	322	71,50	<b>4299,00</b>
236109	600	775x710x(H)1900	645x528x(H)1643	rafturi fixe, 6x 588x496	R290	65	230	436	91,50	<b>4809,00</b>

Pret catalog fara TVA



433





237809

### DULAP FRIGORIFIC REFRIGERARE CU 1 USA PENTRU COFETARIE

- Carcasa fabricata din otel inoxidabil AISI 304.
- 10 ghidaje din otel inoxidabil, pentru rafturi/tavi pentru dulciuri cu dimensiunile de 600x400 mm.
- 30 de niveluri pentru amplasarea ghidajelor.
- Izolatie din poliuretan cu grosime de 60 mm.
- Usa cu auto-inchidere.
- Schimbarea directiei usii este posibila.
- Prevezut cu un termostat digital cu afisaj.
- Racire statica acceptata cu un ventilator cu viteza reglabila.
- Interval de temperatura: de la -2°C la 8°C.
- Incarcatura maxima de ghidaje: 15 kg pentru fiecare pereche.
- Agent frigorific: R455a.

cod	litri	V	W	mm	lei
237809	413	230	380	710x800x(H)2100	9299,00



237816

### DULAP FRIGORIFIC REFRIGERARE CU 1 USA PENTRU COFETARIE

- Carcasa fabricata din otel inoxidabil AISI 304.
- 10 ghidaje din otel inoxidabil, pentru rafturi/tavi pentru dulciuri cu dimensiunile de 600x400 mm.
- 30 de niveluri pentru amplasarea ghidajelor.
- Izolatie din poliuretan cu grosime de 60 mm.
- Usa cu auto-inchidere.
- Schimbarea directiei usii este posibila.
- Prevezut cu un termostat digital cu afisaj.
- Racire statica.
- Interval de temperatura: de la -18°C la -22°C.
- Incarcatura maxima de ghidaje: 15 kg pentru fiecare pereche.
- Agent frigorific: R455a.

cod	litri	V	W	mm	lei
237816	413	230	557	710x800x(H)2100	11399,00

## DULAPURI PENTRU MATURAREA CARNII

**arktic**  
PROFESSIONAL REFRIGERATION

ABS  
plastic

18/10  
stainless steel

indoor

- Corpul, cadrul usii si manerul usii sunt fabricate din otel inoxidabil AISI 304.
- Usa fabricata din 2 straturi de sticla temperata colorata Low-E, care creste eficienta energetica prin blocarea luminii infrarosii si a razelor UV din exterior, impiedicand in acelasi timp transferul de caldura in interior. Incuietoarea usii este inclusa.
- Recipient pentru apa distilata fabricat din ABS - apa distilata trebuie umpluta manual.
- Notificare pe afisaj si alarma sonora pentru a avertiza atunci cand umiditatea este sub 15% pentru ca utilizatorul sa umple recipientul de apa.
- Alarma care indica faptul ca usa este deschisa mai mult de 3,5 minute - protectie impotriva perturbarii necontrolate a conditiilor din camera.
- Lampa de sterilizare UVC incorporata pentru a preveni dezvoltarea bacteriilor si pentru a garanta un mediu sigur pentru carne; atunci cand usa este deschisa in timpul procesului de condimentare, bacteriile nu au posibilitatea de a se dezvolta.

- Racire forzata prin intermediul unui ventilator care asigura nivelul necesar de circulatie a aerului.
- Lumini LED plasate pe ambele parti ale camerei si pe tavan.
- Sarcina maxima pe cartig: 25 kg.
- Sarcina maxima a tijeii de agatat: 50 kg.
- Intervalul de temperatura: 1-25 °C.
- Interval de umiditate reglabil: 60-85%.
- Nivelul actual de umiditate este afisat pe panou.
- Agent frigorific: R600a.

**NOU**



221426

### DULAP PENTRU MATURAREA CARNII, DE BANC

- Incarcare maxima pe raft: 30 kg.
- In cabinet se afla:
  - raft,
  - 1 tija agatare cartilge macelarie,
  - 3 cartilge,
  - tava pentru sare (sarea nu este inclusa),
- Toate elementele de mai sus sunt fabricate din otel inoxidabil AISI 304.

cod	litri	V	W	mm	lei
221426	98	230	170	595x620	<b>10549,00</b>
					x(H)830



221433

### DULAP PENTRU MATURAREA CARNII

- Incarcare maxima pe raft: 30 kg.
- In cabinet se afla:
  - 3 rafturi,
  - 1 tija agatare cartilge macelarie,
  - 3 cartilge,
  - tava pentru sare (sarea nu este inclusa),
- Toate elementele de mai sus sunt fabricate din otel inoxidabil AISI 304.

cod	litri	V	W	mm	lei
221433	233	230	170	595x760	<b>12849,00</b>
					x(H)1270



204962

### DULAP PENTRU MATURAREA CARNII

- Incarcare maxima pe raft: 25 kg.
- In cabinet se afla:
  - 3 rafturi,
  - 1 tija agatare cartilge macelarie,
  - 3 cartilge,
  - tava pentru sare (sarea nu este inclusa),
- Toate elementele de mai sus sunt fabricate din otel inoxidabil AISI 304.

cod	litri	V	W	mm	lei
204962	352	230	170	695x760	<b>13499,00</b>
					x(H)1720



## ABATITOR I BLASTCHILLER

**arktic**  
PROFESSIONAL REFRIGERATION

**S.S.**  
stainless steel

**cooling**

- Permite racirea rapida sau inghetarea felurilor de mancare pregatite.
- Racire de la 70 °C la 3 °C (90 min), de la 70 °C la -18 °C (240 min) sau într-un timp prestabilit (fara a indica temperatura tinta).
- Carcasa exteriora si camera interioara sunt din otel inoxidabil de inalta calitate.
- Camera interioara cu culturi rotunjite pentru o curatare mai usoara.
- Racire cu aer comprimat cu auto-dezghetare, compresor amplasat sub camera.
- Izolatie de spuma poliuretanică de grosime de 60 mm.
- Capac detasabil detasabil.
- Usa cu inchidere automata cu garnitura magnetica.
- Regulatorul de temperatura digital si afisajul.
- Probe incluse.
- Montat cu 4 picioare ajustabile din otel inoxidabil.
- Clasa climatica: SN-T.
- Agent de racire: R455.



232163



232170



232194



232187



232491

cod	capacitate interioara	spatiu intre tavi (mm)	racire la +3°C (kg/ciclu)	racire la -18°C (kg/ciclu)	V	W	dimensiuni interioare (mm)	mm	kg	lei
232163	3x GN 1/1 sau 3x 600x400	70	14	11	230	1150	610x410x(H)280	750x740x(H)750	50	<b>11799,00</b>
232170	5x GN 1/1 sau 5x 600x400	70	20	15	230	1420	610x410x(H)410	750x740x(H)880	71	<b>12599,00</b>
232194	7x GN 1/1 sau 7x 600x400	105	25	20	230	1490	610x410x(H)760	750x740x(H)1290	90	<b>20599,00</b>
232187	10x GN 1/1 sau 10x 600x400	70	25	20	230	1490	610x410x(H)760	750x740x(H)1290	90	<b>21849,00</b>
232491	15x GN 1/1 sau 15x 600x400	70	45	35	400	1820	610x410x(H)1120	750x740x(H)1850	120	<b>35999,00</b>
232507	20x GN 1/1 sau 20x 600x400	65	50	40	400	2040	610x410x(H)1360	750x740x(H)2080	150	<b>48999,00</b>





**arktic** ❄️  
TECNOLOGIA DE CONGELARE



237731

### RACITOR CU JET 3X GN 2/3

- Pentru racirea sau congelarea rapida a alimentelor preparate, congelarea prajiturilor, deserturilor, pestelui sau inghetatei
- Exterior si interior camera din otel inoxidabil, baza din otel galvanizat
- Camera cu colturi interne rotunjite pentru o curatare usoara
- 3 ghidaje din otel inoxidabil adecvate pentru GN 2/3
- Izolatie din poliuretana de 60 mm, injectata sub presiune inalta
- Usa autoblocanta cu balamale pentru mana stanga si garnitura magnetica
- Panou frontal cu control electronic si afisaj
- Acces facil la condensator pentru curatare si intretinere

- Decongelare manuala cu usa deschisa
- Tava de picurare detasabila
- Distanta dintre ghidaje: 80 mm
- Capacitate de racire (la 9 kg:  $+65\text{ }^{\circ}\text{C}/+3\text{ }^{\circ}\text{C}$ ) in max. 90 min
- Capacitate de congelare la 7 kg:  $+65\text{ }^{\circ}\text{C}/-18\text{ }^{\circ}\text{C}$  in 240 de minute
- Agent de racire: R455
- Racire forzata cu ventilator
- Camera si sonda centrala incluse
- Picioare reglabile (pana la 20 mm)

cod	V	W	mm	lei
237731	230	550	663x672x(H)415	<b>10549,00</b>

### Racire rapida de la $+90^{\circ}\text{C}$ la $+3^{\circ}\text{C}$

Acest proces ajuta la scaderea temperaturii alimentelor la valoarea sigura de  $+3^{\circ}\text{C}$ , intr-un timp adecvat, in conformitate cu standardele HACCP.

Viteza de racire adecvata ajuta la reducerea inmultirii bacteriilor in intervalul  $+65^{\circ}\text{C}/+10^{\circ}\text{C}$ .

Acest tip de racire ajuta la mentinerea calitatii, culorii si mirosurilor alimentelor si prelungeste perioada de depozitare.

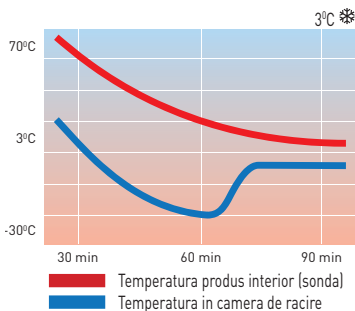

### Congelare rapida de la $+90^{\circ}\text{C}$ la $-18^{\circ}\text{C}$

Sistemul puternic de congelare si aerul de  $-40^{\circ}\text{C}$  introdus in camera duc la scaderea rapida a temperaturii din interiorul alimentelor, pana la  $-18^{\circ}\text{C}$ .

Impiedica aparitia unor cristale de gheata mari, ce dauneaza structurii interne a alimentelor.

Congelarea rapida are ca rezultat un numar mare de cristale mici, ce pastreaza proprietatile originale ale alimentelor: aroma, culoare, textura si nutrientii, si ajuta la prelungirea perioadei de depozitare.

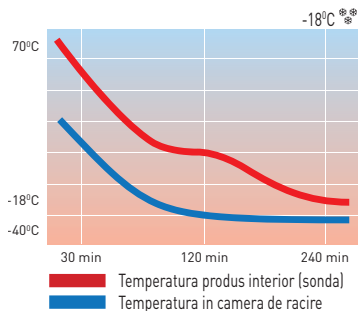



Vezi filmul



233757



Posibilitatea de a plasa un grafic



### AFISAJ SUSHI 5X GN 1/3 ARKTC

- Carcasa alba din otel inoxidabil acoperit.
- Capac dublu, curbat, din sticla in fata.
- Accesibil prin doua usi glisante in spate sau prin intermediul capacului de sticla curbat, ridicat.
- Racire statica cu dezghetare automata.
- Raceste de la 0 °C la 6 °C.
- Compatibil cu 5x GN 1/3 - max. (H)40 mm.
- Prevazut cu LED-uri si evaporator in partea de sus.

- Controler digital de temperatura si afisaj.
- Agent frigorific: R600a .
- Clasa de eficienta energetica: B.
- Clasa climatica: 3.
- Recipientele GN nu sunt incluse.

cod	gama	V	W	mm	lei
233757	0/6°C	230	160	1307x445x(H)327	2739,00



**NOU**

274040



### VITRINA PREZENTARE SUSHI

- Carcasa fabricata din otel inoxidabil, cu carcasa realizata din placaj, de culoare neagra.
- Cu sticla calita.
- Acces convenabil la interiorul camerei datorita usilor glisante situate in spate.
- Racire statica cu functie de decongelare automata.
- In interiorul camerei sunt instalate lumina LED si un evaporator.
- Afisaj digital si termostat electronic.

- Interval de temperatura: 0-12°C.
- Clasa climatica: 4.
- Eticheta energetica: C.
- Agent frigorific: R600a .
- Capacitate: 5x GN 1/2 (containere incluse).

cod	mm	lei
274040	1800x420x(H)265	3629,00



Vezi filmul



233689

### VITRINA CONGELARE PENTRU INGHETATA, ARKTC

- Destinat prezentarii si servirii pana la 4 ore.
- Nu este destinat depozitarii pe termen lung a produselor congelate.
- Corp fabricat din otel inoxidabil de inalta calitate, prevazut cu capac triplu cu sistem de deschidere usoara.
- Racire forzata cu aer cu decongelare automata, compresor amplasat langa camera.
- Se potriveste 8x GN 1/6 containere sau 4x GN 1/3 containere, se potrivec containere inalte de 150 mm; GN nu este incluse.
- Cu 4 picioare reglabile din otel inoxidabil.
- Controler digital de temperatura si afisaj.
- Agent frigorific: R290.
- Clasa climatica: 4
- Eticheta energetica: E (A-G).

cod	gama	V	W	mm	lei
233689	-25/-18°C	230	210	800x680x(H)670	4159,00

## VITRINE PREZENTARE – REFRIGERARE



Vezi filmul

arktic



233702



233719



### VITRINA DE PREZENTARE

- Carcasa din otel inoxidabil prevazuta cu capac frontal din sticla curbata si panouri laterale din sticla.
- Accesibil prin doua usi glisante din sticla din spate.
- Racire cu aer comprimat cu auto-dezghetare, compresor amplasat sub camera.
- 2 rafturi cromate incluse.
- Lumina LED-uri luminoase in tavan.
- Regulatorul de temperatura digital si afisajul.
- Interval de temperatura: 0° / 6°C.
- Clasa climatica: 4
- Agent de racire: R600a.
- Clasa energetica: B.

cod	litri	V	W	mm	lei
233702	120	230	160	707x570x(H)680	2899,00
233719	160	230	160	885x570x(H)680	3199,00



Racire fortata cu aer



Afisaj digital



### VITRINA PREZENTARE SALATE, ARKTIC

- Corp din otel inoxidabil de inalta calitate, prevazut cu capac de sticla curbata cu sistem de deschidere usoara.
- Racire fortata cu aer cu decongelare automata, compresor amplasat langa camera.
- Se potriveste 8x GN 1/6 GN containere sau 4x GN 1/3 containere, se potrivesc containere inalte de 100 mm; GN nu este inclus.
- Cu 4 picioare reglabile din otel inoxidabil.
- Controler si afisaj digital de temperatura.
- Agent frigorific: R600a.
- Clasa climatica: 4
- Eticheta energetica: C.

cod	gama	V	W	mm	lei
233672	0/3°C	230	105	775x615x(H)235	3399,00



Vezi filmul



233672



233412



## DULAP FRIGORIFIC CONGELARE CU USA DIN STICLA

- Carcasa interioara realizata din polistiren de inalta calitate (HIPS) si polipropilena. Carcasa exterioara din otel vopsit.
- Usa care poate fi blocata, este prevazuta cu un geam triplu si un element de incalzire pentru a preveni formarea condensului.
- Racire cu aer rece cu dezghetare automata, compresor amplasat sub camera.
- Montat cu 3 rafturi reglabile din PVC.
- Cu iluminare LED in partea de sus a congelatorului.
- Regulatorul de temperatura si afisaj digital.
- Clasa climatica: 4
- Agent de racire: R290.
- Clasa energetica: C.

cod	gama	V	W	mm	lei
233412	-14/-22°C	230	230	620x593x(H)680	3029,00



233436



## MASA RECE - USI STICLA

- Structura din otel inoxidabil AISI 201 de calitate superioara (peretele din spate din otel galvanizat, tocul usii din aluminiu)
- Racire fortata
- Grosimea izolatiei: 60 mm (material: C5H10)
- Usi cu auto-inchidere
- 4 picioare reglabile fixe din otel inoxidabil
- Afisaj digital, termostat electronic
- Unitate frigorifica EMBRACO
- Evaporarea automata a condensului
- Functionare optima la temperatura ambianta de pana la 43°C
- Marginea 40 mm

tip	refrigerare, 3-usi
cod	233436
capacitate	420 l
dimensiuni	1795x700x(H)850 mm
dim. interioare	1257x570x(H)580 mm
temperatura	0/8°C
compresor	FFI10HAK putere 1/3 KM
refrigerant	R290 (130 g)
clasa climatica	5
rafturi	2+2+2 x 330x545 mm*
consum mediu zilnic	3,15 kWh
putere/tensiune	400 W/230 V
greutate	125 kg
lei	6999,00

NOU

arktic PROFESSIONAL EQUIPMENT

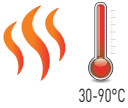

30-90°C

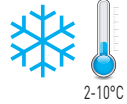

2-10°C

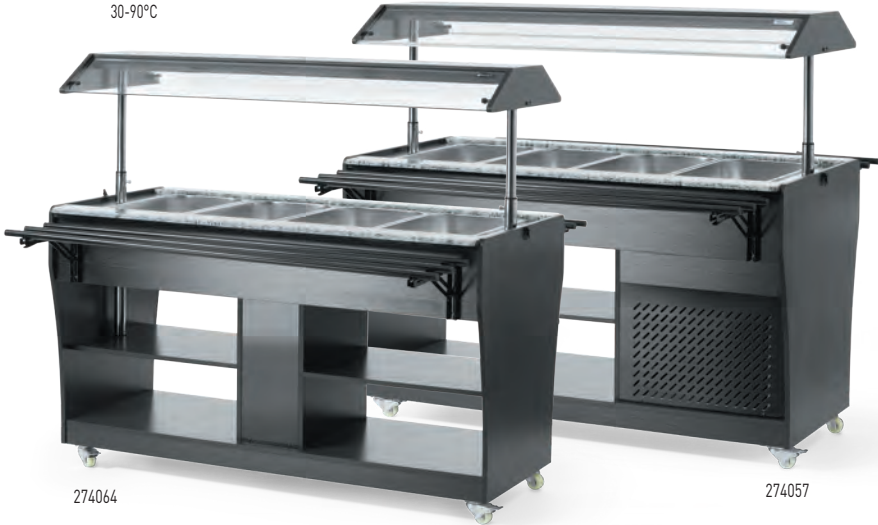

274064

274057



### BUFET CALD

- Carcasa fabricata din otel inoxidabil cu placaj negru.
- Adecvat pentru 4 recipiente GN 1/1 - adancime max. 150 mm.
- Furnizat cu 4 recipiente GN 1/1.
- Prevazut cu iluminare.
- Partea superioara poate fi coborata pentru a actiona ca un capac, fixat cu incuietori.
- Ghidajele tavii pliabile pe ambele parti.
- 2 polite.
- Echipat cu 4 roti.
- Temperatura reglabila de la 30°C la 90°C.

cod	interval temp.	V	W	mm	lei
274064	30/90°C	230	2000	1490x765x(H)1370	9359,00

### BUFET DE SALATA

- Carcasa fabricata din otel inoxidabil cu placaj negru.
- Adecvat pentru 4 recipiente GN 1/1 - adancime max. 150 mm.
- Furnizat cu 4 recipiente GN 1/1.
- Prevazut cu iluminare.
- Partea superioara poate fi coborata pentru a actiona ca un capac, fixat cu incuietori.
- Ghidaje de tava pliabile pe ambele parti.
- Polita sub blat.
- Echipat cu 4 roti.
- Temperatura reglabila de la 2°C la 10°C.
- Clasa climatica: 4.

cod	interval temp.	V	W	mm	lei
274057	2/10°C	230	170	1490x765x(H)1370	9359,00



## VITRINE FRIGORIFICE DE PREZENTARE

arktic

S.S.  
stainless steel

cooling

- Cadru vitrina din polimeri ABS+PVC, cu sticla dubla.
- Carcasa unitatii din ABS.
- Racire cu aer forat cu auto-decongelare, compresor amplasat sub camera.
- Aerul este suflat peste geamul din sticla, pentru a preveni condensul.

- Rafturi rezistente acoperite cu PVC, cu inaltime reglabila.
- Cu lumina LED puternica in tavan.
- Controler digital de temperatura si afisaj.
- Clasa climatica: 4



Vezi filmul



233610

C A G



233627

C A G



233634

C A G

ECHIPAMENTE FRIGORIFICE

### VITRINA FRIGORIFICA DE PREZENTARE 58 L

- Cu 2 rafturi.
- Dotat cu un compresor cu inverter eficient din punct de vedere energetic, regleaza puterea in functie de necesitati, in loc sa porneasca sau sa se opreasca.
- Clasa energetica: C (A-G).
- Interval de temperatura: 2/6 °C.
- Agent de racire: R600A.

cod	-	V	W	mm	lei
233610	alba	230	170	444x397x(H)795	1899,00
233627	neagra	230	170	444x397x(H)795	1899,00

### VITRINA FRIGORIFICA DE PREZENTARE 68 L

- Cu 3 rafturi.
- Dotat cu un compresor cu inverter eficient din punct de vedere energetic, regleaza puterea in functie de necesitati, in loc sa porneasca sau sa se opreasca.
- Clasa energetica: C (A-G).
- Interval de temperatura: 2/6 °C.
- Agent de racire: R600A.

cod	-	V	W	mm	lei
233634	alba	230	170	444x397x(H)875	1999,00
232328	neagra	230	170	444x397x(H)875	1999,00



Conducta de aer din exteriorul sticlei pentru a inlatura si preveni condensul



Usa vitrata dubla si usa usor de deschis



Controler digital



233641



233658



233665



233696



### VITRINA DE PREZENTARE 78 L

- Cu 3 rafturi.
- Dotat cu un compresor cu invertor eficient din punct de vedere energetic, regleaza puterea in functie de necesitati.
- Clasa energetica: C (A-G).
- Interval de temperatura: 2/6 °C.
- Agent de racire: R600A.

cod	-	V	W	mm	lei
233641	alba	230	170	444x397x(H)940	2099,00
233658	neagra	230	170	444x397x(H)940	2099,00

### VITRINA FRIGORIFICA DE PREZENTARE 98 L

- Cu 4 rafturi.
- Dotat cu un compresor cu invertor eficient din punct de vedere energetic, regleaza puterea in functie de necesitati.
- Clasa energetica: C (A-G).
- Interval de temperatura: 2/6 °C.
- Agent de racire: R600A.

cod	-	V	W	mm	lei
233665	alba	230	210	444x397x(H)1100	2299,00
233269	neagra	230	210	444x397x(H)1100	2299,00



4 roti, 2 cu frana  
(233696, 233290)



Usa cu geam dublu  
si deschidere usoara  
(233696, 233290)

### VITRINA FRIGORIFICA VERTICALA 270 L

- Cu 5 rafturi si roti din care 2 cu frane
- Clasa energetica: C.
- Interval de temperatura: 0/6 °C.
- Agent de racire: R290.

cod	-	V	W	mm	lei
233290	neagra	230	290	550x520x(H)1870	4409,00
233696	alba	230	290	550x520x(H)1870	4319,00





Vezi filmul



233825

### VITRINA ROTUNDA DE PREZENTARE PRAJITURI

- Carcasa din otel inoxidabil prevazuta cu geam dublu.
- Acces prin usa cu inchidere manuala.
- Racire cu aer rece, cu auto-dezghetare si compresor amplasat sub camera.
- Montat cu 3 rafturi reglabile din sticla.
- Luminos cu LED-uri luminoase pe 2 laturi.
- Regulator digital de temperatura si afisaj, cu comutator pornit / oprit.
- Interval de temperatura: 0° / 6°C.
- Clasa climatica: 6
- Agent de racire: R600a.
- Clasa energetica: B.

cod	litri	V	W	mm	lei
233825	100	230	210	ø480	<b>3229,00</b>
x(H)1065					



233832

### VITRINA ROTUNDA DE PREZENTARE PRAJITURI

- Carcasa din otel inoxidabil prevazuta cu geam termopan.
- Accesibil prin usa cu inchidere manuala.
- Racire cu aer comprimat cu auto-dezghetare, compresor amplasat sub camera.
- Montat cu 4 rafturi de sticla reglabile.
- Luminos cu LED-uri luminoase pe 2 laturi.
- Montat cu 5 roti din care 2 are o frana.
- Regulator digital de temperatura si afisaj, cu comutator pornit / oprit.
- Interval de temperatura: 0° / 6°C.
- Clasa climatica: 4
- Agent de racire: R290.
- Clasa energetica: B.

cod	litri	V	W	mm	lei
233832	360	230	460	ø680	<b>9449,00</b>
x(H)1755					



Vezi filmul



233283

### VITRINA DE PREZENTARE TIP DULAP

- Carcasa din otel inoxidabil prevazuta cu geam triplu.
- Racire cu aer comprimat cu auto-dezghetare, compresor amplasat sub camera.
- Montat cu 3 rafturi cromate reglabile.
- Iluminare puternica cu LED in cele 4 posturi.
- Montat cu 4 roti din care 2 au frane.
- Regulator digital de temperatura si afisaj, cu comutator pornit / oprit.
- Interval de temperatura: 0/6 ° C.
- Clasa climatica: 4
- Agent de racire: R290.
- Clasa energetica: B.

cod	litri	V	W	mm	lei
233283	550	230	500	850x650	<b>10899,00</b>
x(H)1908					

## VITRINE DE PREZENTARE CU ACCES PRIN SPATE

- Carcasa din otel inoxidabil prevazuta cu geam dublu.
- Acces prin spate cu ajutorul usii cu maner.
- Racire cu aer comprimat cu auto-dezghetare, compresor amplasat sub camera de racire.
- Cu iluminare LED luminoasa in partea superioara si sub fiecare raft.
- Montat cu 4 roti din care 2 au frane.
- Termostat si afisaj digital.
- Agent de racire: R290.

**arktic** 

**S.S.**  
stainless steel

  
cooling



Vezi filmul



233320



233450

## VITRINA FRIGORIFICA CU 3 RAFTURI INCLINATE

- Montat cu 3 rafturi reglabile din sticla usor inclinate.
- Clasa energetica: B.
- Interval de temperatura: 0° / 6°C

cod	litri	V	W	mm	lei
233320	650	230	490	1200x833x(H)1460	<b>9599,00</b>

## VITRINA FRIGORIFICA CU 2 RAFTURI

- Montat cu 2 rafturi de sticla reglabile.
- Clasa energetica: B.
- Interval de temperatura: 0° / 6°C

cod	litri	V	W	mm	lei
233450	410	230	490	1224x677x(H)1230	<b>8479,00</b>
233467	610	230	500	1824x677x(H)1230	<b>13049,00</b>



Iluminare cu LED-uri



Controler electronic pentru temperatura



4 roti rotative



## VITRINE FRIGORICE BAR

**arctic**  
PROFESSIONAL DISTRIBUTION

- Carcasa acoperita cu pulbere, camera din aluminiu reliefata, usa (usi) cu inchidere din plastic, sticla securizata.
- Racire cu aer comprimat cu auto-dezghetare, compresor amplasat sub camera.

- Camera prevazuta cu iluminat cu LED.
- Afisaj digital si control al temperaturii.
- Montat cu 4 picioare reglabile anti-alunecare.
- Agent de racire: R600a.



	1 usa	1 usa	2 usi	glisanta dubla
cod	233900	226568	235829	233917
capacitate	86 L	105 L	158 L	158 L
dimensiuni	500x530x(H)865 mm	600x530x(H)865 mm	900x530x(H)865 mm	900x520x(H)865 mm
rafturi	2 cromate	3 cromate	4 cromate	4 cromate
dim. rafturilor	402x353 mm	502x353 mm	399x346 mm	399x346 mm
refrigerant	R600a	R600a	R600a	R600a
putere/tensiune	120 W/230 V	120 W/230 V	160 W/230 V	160 W/230 V
greutate	34 kg	38,50 kg	55,50 kg	53,50 kg
lei	<b>1999,00</b>	<b>2149,00</b>	<b>2849,00</b>	<b>2899,00</b>



glisanta dubla



1 usa



2 usi

	glisanta dubla	1 usa	2 usi
cod	235836	233924	233931
capacitate	254 L	243 L	384 L
dimensiuni	1350x520x(H)865 mm	578x605x(H)1980 mm	940x635x(H)1983 mm
rafturi	6 cromate	4 cromate	8 cromate
dim. rafturilor	2x 399x346 mm, 1x 446x346 mm	492x353 mm	392x353 mm
refrigerant	R600a	R600a	R290a
putere/tensiune	160 W/230 V	195 W/230 V	365 W/230 V
greutate	76 kg	67 kg	89 kg
lei	<b>4999,00</b>	<b>3149,00</b>	<b>5049,00</b>



## DULAPURI FRIGORIFICE CU DISPLAY SI CASETE LUMINOASE

**arktic**  
REFRIGERATION

**Al**  
aluminium

**PP**  
polypropylene

**S.S.**  
stainless steel

- Fabricat din oțel inoxidabil, aluminiu și polipropilenă.
- Uși prevăzute cu geam triplu, din care un strat este securizat.
- Racire cu aer comprimat cu auto-dezghetare, compresor amplasat sub camera.
- Cu iluminare LED în camera și în caseta de lumina.

- Montat cu 4 roți din care 2 au frâne.
- Regulatorul de temperatură și afișajul digital.
- Clasa climatică: N-ST.



233788



233795

	1 usa cu display 233788	2 usa cu display 233795
cod	233788	233795
capacitate	254 L	512 L
dimensiuni	578x605x(H)1980 mm	1120x585x(H)1900 mm
rafturi	4 rafturi din PVC reglabile	8 rafturi din PVC reglabile
dimensiuni rafturi	492x353 mm	392x353 mm
refrigerant	R600a	R290
putere/tensiune	250 W/230 V	510 W/230 V
greutate	75 kg	111 kg
lei	<b>4199,00</b>	<b>6499,00</b>

Iluminare cu LED-uri în lightbox.



Iluminat cu LED-uri în camera.



Plasare ajustabilă pe rafturi



Echiptat cu 4 roți din care 2 au frâne.



## DULAPURI FRIGORIFICE PENTRU VIN CU REGLARE TEMPERATURA IN 2 ZONE



- Zona dubla permite setarea a doua temperaturi diferite pentru cele doua zone.
- Carcasa neagra acoperita cu pudra, usa din sticla securizata, fara margini, dotata cu maner stilat din otel inoxidabil.
- Racire forzata a aerului cu auto-decongelare, compresorul amplasat in spatele camerei.
- Cu iluminare cu LED-uri aprinse in tavan.

- Controler digital pentru temperatura si afisaj.
- Se poate seta in Celsius sau Fahrenheit.
- Prevazut cu 4 picioare antiderapante reglabile.
- Clasa climat: N-ST.
- Agent frigorific: R600a.

## TEMPERATURA IDEALA A VINURILOR (DE LA ROSU LA ALB):

Temperatura	Tip de vin
18°C	Bordeaux, Cabernet Sauvignon, Shiraz
16°C	Rioja, Pinot Noir
15°C	Chianti, Zinfandel
14°C	Chinon, Porto, Madeira
10°C	Chardonnay, Sauternes
9°C	Sauvignon Blanc
6°C	Champagne Non Vintage, Prosecco, Cava, Asti



cod	237588	237557	237564	237595
capacitate	133 L pana la 46 de sticle de vin	232 L pana la 72 de sticle de vin	387 L pana la 135 de sticle de vin	447 L pana la 160 de sticle de vin
dimensiuni	595x588x(H)820 mm	595x605x(H)1225 mm	595x680x(H)1625 mm	595x685x(H)1795 mm
rafturi	5 din lemn	9 din lemn	13 din lemn	15 din lemn
temperatura	5/22°C	5/22°C	5/22°C	5/22°C
refrigerant	R600a	R600a	R600a	R600a
clasa energetica	G	G	G	G
clasa climatica	N-ST	N-ST	N-ST	N-ST
putere/tensiune	90 W/230 V	110 W/230 V	130 W/230 V	150 W/230 V
lei	<b>3179,00</b>	<b>3759,00</b>	<b>6199,00</b>	<b>6999,00</b>



## APARAT PENTRU GHEATA



- Aparatul este conceput pentru a fi utilizat in baruri, pub-uri, cafelele si restaurante.
- Carcasa robusta fabricata din otel inoxidabil AISI 304.
- Interior din plastic.
- Orificiile de aerisire din partea frontala a carcasei pentru a permite instalarea sub blat a aparatului de facut gheata.
- Aparatul utilizeaza metoda de pulverizare pentru a turna perfect cuburile cu orificii hexagonale care are o suprafata de racire mai mare si asigura un timp de racire mai lung, reducand la minimum dilutiile bauturilor.

- Performanta si durata de viata extinse ale compresorului.
- Functionare eficienta la o temperatura ambianta de pana la 42°C. Consum redus de energie.
- Reglarea nivelului de umplere a recipientului pentru gheata.
- Picioare reglabile.
- Curatare usoara grazie componentelor detasabile.
- Furtunurile de admisie si evacuare si paleta pentru gheata incluse.

**SISTEM  
HIBRID - CONSUM  
REDUS  
DE ENERGIE**

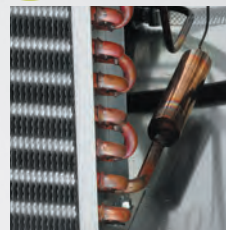

**INTERCOOLING**  
- metoda inovatoare de schimbare a caldurii prin intermediul unui condensator suplimentar - recuperare a caldurii compresorului utilizata pentru dezghetarea placii de pulverizare.

Cuburi transparente cu forma hexagonala - suprafata mai mare de racire, timp de racire mai mare, reducand in acelasi timp la minimum dilutiile



cod	C-180	C-250 FA	C-400	C-660	C-1200
eficienta	18 kg/24 h	28 kg/24 h	40 kg/24 h	65 kg/24 h	120 kg/24 h
capacitatea buncaului	10-11 kg	12-13 kg	16-18 kg	30-35 kg	45-50 kg
dimensiuni	400x400x(H)650 mm	400x460x(H)670 mm	480x580x(H)750 mm	600x580x(H)820 mm	820x580x(H)940 mm
refrigerant	R134	R454c	R454c	R454c	R454c
putere/tensiune	180 W/230 V	295 W/230 V	455 W/230 V	720 W/230 V	844 W/230 V
greutate	28 kg	32 kg	44 kg	55 kg	83 kg
lei	<b>4299,00</b>	<b>5849,00</b>	<b>5999,00</b>	<b>7509,00</b>	<b>13199,00</b>





NOU



271353

#### APARAT DE FACUT CUBURI DE GHEATA

- Carcasa fabricata din otel inoxidabil.
- Produce cuburi de gheata transparente care se topecs mai lent decat alte tipuri de gheata.
- Racit cu aer - racire statica asistata de ventilator.
- Indicatori pentru nivelul scazut al apei si pentru recipientul plin cu gheata.
- Functiile de decongelare automata si de curatare automata.
- Capacitate recipient gheata: 6 kg.
- Capacitate de productie: 22 kg/24 h.
- Agent frigorific: R290.

cod	V	W	mm	lei
271353	230	260	380x520x(H)637	4329,00



271360

#### APARAT DE FACUT CUBURI DE GHEATA

- Carcasa fabricata din otel inoxidabil.
- Produce cuburi de gheata transparente care se topecs mai lent decat alte tipuri de gheata.
- Racit cu aer - racire statica asistata de ventilator.
- Indicatori pentru nivelul scazut al apei si pentru recipientul plin cu gheata.
- Functiile de decongelare automata si de curatare automata.
- Capacitate recipient gheata: 42 kg.
- Capacitate de productie: 90 kg/24 h.
- Agent frigorific: R290.

cod	V	W	mm	lei
271360	230	900	730x600x(H)1136	10549,00

## TAVI PREZENTARE

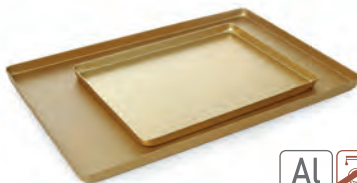
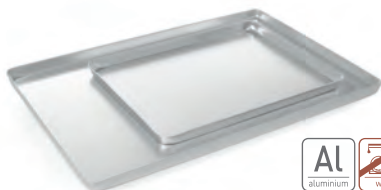

## TAVA PREZENTARE ARGINTIE

cod	mm	lei
808467	300x200x(H)20	46,99
808504	400x300x(H)20	49,99
808511	600x400x(H)20	65,99

## TAVA PREZENTARE AURIE

cod	mm	lei
808559	300x200x(H)20	69,99
808566	400x300x(H)20	81,99
808573	600x400x(H)20	104,99

## TAVI PREZENTARE MELAMINA



808542



568200

## TAVA CARNE

- Melamina neagra



cod	mm	lei
568101	290x160x(H)35	39,99
568200	350x250x(H)40	79,99
568309	420x280x(H)60	104,99



568804

## TAVA CARNE

- Melamina neagra



cod	mm	lei
568804	280x210x(H)60	78,99

## TAVA PREZENTARE - NEAGRA



cod	mm	lei
808528	300x200x(H)20	79,99
808535	400x300x(H)20	99,99
808542	600x400x(H)20	124,99



568507

## TAVA CARNE

- Melamina neagra



cod	mm	lei
568408	290x160x(H)60	55,99
568507	300x190x(H)80	76,99



569108

## TAVA EXPUNERE

- Melamina neagra



cod	mm	lei
569009	270x210x(H)17	49,99
569016	300x150x(H)17	44,99
569108	300x190x(H)17	50,99
569207	350x240x(H)17	65,99

## TAVI PREZENTARE DIN OTEL INOXIDABIL



407202

### TAVA EXPUNERE

- Cu picioare



cod	mm	lei
407202	240x170	44,99



407400

### TAVA DE PREZENTARE

- Nu este adecvata pentru temperaturi ridicate



cod	mm	lei
407400	345x245	64,99



408308

### TAVA EXPUNERE



cod	mm	lei
408308	310x230	54,99



508206

### TAVA CARNE



cod	mm	lei
508107	260x200x(H)48	79,99
508206	310x240x(H)48	99,99



429419

### DISPENSER SANDWICH

- Pentru 7 sandwich-uri



cod	mm	lei
429419	475x105x(H)60	79,49

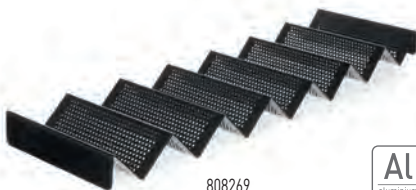

808269

### DISPLAY PENTRU EXPUNERE SANDWICH, PERFORAT

- Pentru 7 sandwich-uri.



cod	mm	lei
808269	580x170x(H)40	139,99



429457

### SUPPORT TACO



cod	-	mm	lei
429440	2 fante	135x115x(H)50	34,99
429457	4 fante	225x115x(H)50	39,99

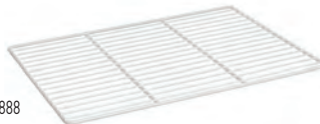

801888

### RAFT PENTRU RACIREA SI CONGELAREA DULAPURILOR GN 2/1, ALB

- Raft din otel, acoperit cu polietilena alba, cablat.

- Dimensiune - GN 2/1.

- Greutate neta: 2,4 kg.

cod	mm	lei
801888	530x650	89,99

# PROFI LINE

PORTELAN, TACAMURI, ARTICOLE MASA



## PROFI LINE

- Elegant, robust.
- Finisaj lucios.

18/0  
stainless steel

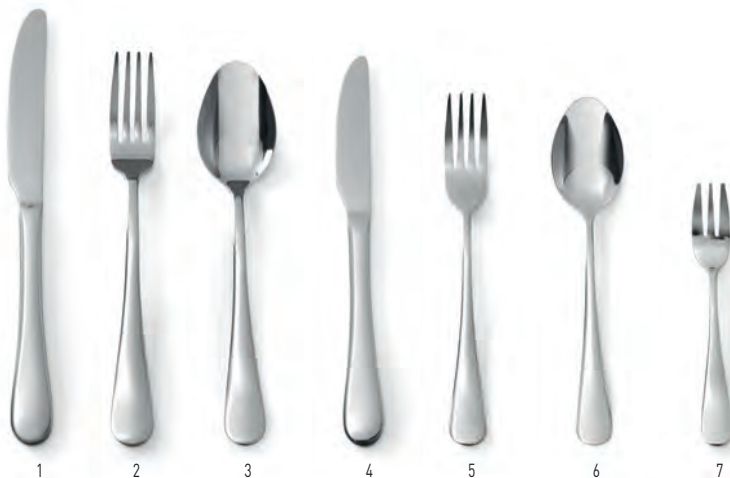

cod	Nr.	ambalat pe	lungime (mm)	lei	cod	Nr.	ambalat pe	lungime (mm)	lei		
764404	1	Cutit	6 bucati	225	44,99	764473	8	Lingurita cafea	12 bucati	111	35,99
764411	2	Furculita	6 bucati	205	28,99	764480	9	Lingurita ceai	12 bucati	138	33,99
764428	3	Lingura	6 bucati	205	28,99	764497	10	Lingurita inghetata	12 bucati	135	35,99
764435	4	Cutit desert	6 bucati	205	39,99	764503	11	Lingurita Sundae	6 bucati	198	25,99
764442	5	Furculita desert	6 bucati	186	26,99	764510	12	Cutit unt	12 bucati	158	37,99
764459	6	Lingurita desert	6 bucati	186	26,99	764527	13	Cutit friptura	6 bucati	215	41,89
764466	7	Furculita tort	12 bucati	136	33,99						





**KITCHEN LINE**  
- Finisaj tip oglinda

18/0  
stainless steel

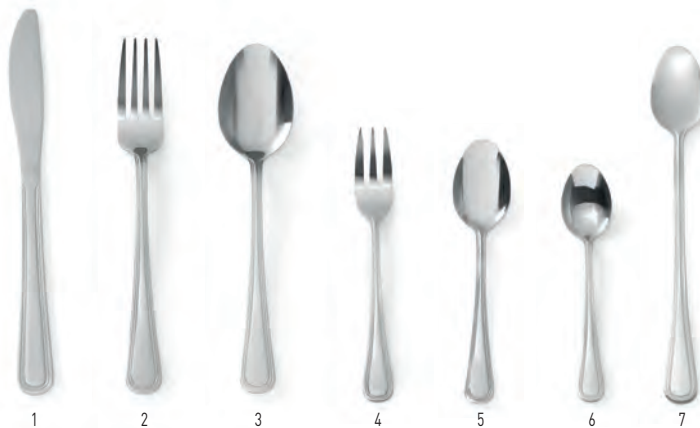

cod	Nr.		ambalat pe	lungime [mm]	lei
764206	1	Cutit	6 bucati	215	21,59
764213	2	Furculita	6 bucati	197	21,99
764220	3	Lingura	6 bucati	197	21,99
764237	4	Furculita tort	12 bucati	150	26,19
764244	5	Lingurita ceai	12 bucati	146	26,19
764251	6	Lingurita cafea	12 bucati	131	26,99
764268	7	Lingurita sorbet	6 bucati	198	19,99



**BUDGET LINE**  
- Lustruite

18/0  
stainless steel



cod	Nr.		ambalat pe	lungime (mm)	lei
764039	1	Lingura	12 bucati	181	<b>17,99</b>
764022	2	Furculita	12 bucati	183	<b>17,99</b>
764015	3	Cutit	12 bucati	212	<b>26,99</b>
764084	4	Lingurita ceai	24 bucati	136	<b>20,99</b>
764091	5	Lingurita cafea	24 bucati	110	<b>19,99</b>
764077	6	Furculita tort	24 bucati	145	<b>20,99</b>
764138	7	Lingurita sorbet	12 bucati	214	<b>20,99</b>



## TACAMURI PENTRU FRIPTURA SI PIZZA

- Maner din lemn natural - durabil, rezistent, potrivit pentru masina de spalat vase

TRAMONTINA



92000007



29899296

### SET DE TACAMURI PENTRU FRIPTURA SI PIZZA, CUTIE DE CADOU - 4 BUCATI

2 cutite pentru friptura/pizza.

- Lama foarte ascutita fabricata din otel inoxidabil.
- Lungime lama: 115 mm.
- Lungime totala: 215 mm.
- Grosimea lamei: 1,2 mm.

2 furculite.

- 2 furculite pentru friptura si pizza.
- Lama fabricata din otel inoxidabil.
- Grosimea furculitei: 1,5 mm.
- Nituire dubla.
- Maner de lemn - durabil, rezistent si poate fi spalat in masina de spalat vase.

cod	culoare	lei
92000007	Maro	55,99

### SET DE TACAMURI PENTRU FRIPTURA CHURRASCO/PIZZA, CUTIE DE CADOU - 8 BUCATI

4 cutite pentru friptura/pizza.

- Lama foarte ascutita fabricata din otel inoxidabil AISI 420.
- Lungime lama: 115 mm.
- Lungime totala: 215 mm.
- Grosimea lamei: 1,2 mm.
- Cu nituire dubla.

4 furculite pentru friptura/pizza.

- Lama fabricata din otel inoxidabil AISI 430.
- Grosimea furculitei: 1,5 mm.
- Nituire dubla.
- Maner de lemn - durabil, rezistent si poate fi spalat in masina de spalat vase.

cod	culoare	lei
29899296	Maro	134,99





## TACAMURI FRIPTURA HENDI

- Otel inoxidabil cu maner ABS

x6



781432

### FURCULITA FRIPTURA - 6 BUCATI

cod	ambalat pe	mm	lei
781432	6	(L)200	28,99

x6



781449

### CUTIT FRIPTURA - 6 BUCATI

cod	ambalat pe	mm	lei
781449	6	(L)215	27,99

x6



781456

### CUTIT FRIPTURA XL - 6 BUCATI

cod	ambalat pe	mm	lei
781456	6	(L)250	49,79

## PLATOURI DE SERVIRE DIN LEMN DE MASLIN

- Fabricat din lemn de maslin, foarte dur si dens. Poate avea crapaturi naturale datorita caracteristicilor lemnului - acestea nu reprezinta defecte.
- Lemnul de masline are proprietati antibacteriene, nu absoarbe mirosurile si nu pateaza si este rezistent la acizi si grasimi.
- Nu poate fi spalat in masina de spalat vase - se recomanda spalarea manuala cu un detergent delicat, apoi uscarea

- cu o laveta din bumbac sau microfibra.
- Pentru a preveni craparea, aplicati din cand in cand ulei de masline sau ulei din seminte de floarea soarelui.
- Observatie: fiecare articol din lemn de masline este unic, si are un model, nuante si forme diferite - forma produsului poate varia fata de imagine.



**NOU**



505427

### PLATOU DE SERVIRE DIN LEMN DE MASLINE

- Ideal pentru servirea gustarilor, cum ar fi mezeluri, branza, masline, gustari, fructe.
- Lungimea placii fara maner: 27 cm.

cod	mm	lei
505427	340x230x(H)22	109,99

**NOU**



505410

### PLATOU DE SERVIRE DIN LEMN DE MASLIN

- Fabricat dintr-o singura bucata de lemn.
- Ideal pentru servirea gustarilor, cum ar fi mezeluri, branza, masline, gustari, fructe.
- O parte dispune de spatiu de colectare, pentru a preveni varsarea lichidelor pe blatul de lucru.

cod	mm	lei
505410	335x205x(H)25	115,99



505168

### TOCATOR DIN LEMN DE MASLIN

- Perfect pentru servirea si prezentarea felurilor de mancare
- Cu manere confortabile, canelate

cod	mm	lei
505168	250x150x(H)18	58,99
505175	300x150x(H)18	70,39
505182	350x150x(H)18	92,59

**NOU**



505434

### PLATOU DE SERVIRE DIN LEMN DE MASLINE

- Ideal pentru servirea gustarilor, cum ar fi mezeluri, branza, masline, deserturi, fructe.
- Lungimea placii fara maner: 40 cm.

cod	mm	lei
505434	480x190x(H)22	123,99

**NOU**



505397

### PLATOU DE SERVIRE DIN LEMN DE MASLINE

- Fabricat dintr-o singura bucata de lemn.
- Ideal pentru servirea gustarilor, cum ar fi mezeluri, branza, masline, gustari, fructe.
- O parte dispune de spatiu de colectare, pentru a preveni varsarea lichidelor pe blatul de lucru.

cod	mm	lei
505397	ø260x(H)25	115,99

**NOU**



505380

### PLATOU DE SERVIRE DIN LEMN DE MASLINE

- Ideal pentru servirea gustarilor, cum ar fi mezeluri, branza, masline, gustari, fructe.
- Lungimea placii fara maner: 32 cm.

cod	mm	lei
505380	ø320x(H)19	162,99





505212

### TOCATOR CU CANELURA DIN LEMN DE MASLIN

- Perfect pentru servirea și prezentarea preparatelor.
- Cu un maner mare pentru transport ușor.
- Disponibil în 3 dimensiuni.

cod	mm	lei
505199	300x210x(H)18	70,39
505212	400x250x(H)18	109,99



505229

### TOCATOR PENTRU BRANZA DIN LEMN DE MASLIN

- Perfect pentru servirea și prezentarea preparatelor.
- Forma organică cu un finisaj de înaltă calitate.
- Cu o gaură mare pentru transport ușor.

cod	mm	lei
505229	250x165x(H)18	59,99
505236	350x210x(H)18	92,59



505243

### TOCATOR PENTRU BRANZA, DIN LEMN DE MASLIN

- Perfect pentru servirea și prezentarea pâinii, aperitivelor etc.
- Cu maner mare pentru transport ușor.

cod	mm	lei
505243	350x120x(H)18	88,99
505250	400x140x(H)18	92,59
505267	600x200x(H)18	168,99



**NOU**
**BOL DIN LEMN DE MASLIN**

- Ideal pentru gustari, cum ar fi nuci, stafide, uleiuri de masline, nachos, fructe si sosuri sau pentru decorarea mesei.
- Poate servi si ca recipient pentru tacamuri.

cod	mm	lei
505335	205x95x(H)50	<b>52,99</b>
505342	300x95x(H)60	<b>68,99</b>
505359	400x90x(H)80	<b>104,99</b>

**NOU**

505328

**BOL DIN LEMN DE MASLIN**

- Ideal pentru gustari, cum ar fi nuci, stafide, uleiuri de masline, nachos, fructe si sosuri sau pentru decorarea mesei.

cod	mm	lei
505311	ø125x(H)60	<b>69,99</b>
505328	ø155x(H)75	<b>104,99</b>

**NOU**

**BOL DECORATIV DIN LEMN DE MASLINE**

- Ideal pentru servirea gustarilor, cum ar fi nuci, stafide, masline, nachos, fructe si, de asemenea, pentru decorarea mesei.
- Optiunea cu codul 505366 are o baza lata.

cod	mm	lei
505373	300x190x(H)110	<b>291,99</b>
505366	365x200x(H)290	<b>373,99</b>



505274

**COS DE PAINE DIN LEMN DE MASLIN**

- Perfect pentru servirea si prezentarea felurilor de mancare.
- Forma organica cu un finisaj de inalta calitate.
- Cu o gaura mare pentru transport usor.
- Disponibil in 2 dimensiuni.

cod	mm	lei
505274	245x198x(H)194	<b>179,99</b>



NOU



505472

505465

### PLATOU DE SERVIRE DIN STEJAR

- Cu o singura fata.
- Constructie cu montant lipit: partea centrala (fibre de lemn orizontale) este intarita cu rame laterale (fibre de lemn verticale).

cod	mm	lei
505472	270x270x(H)20	136,99
505465	370x270x(H)20	162,99

NOU



505489

### PLATOU DE SERVIRE DIN STEJAR

- Cu doua fete.
- Construit cu grija din lemn de stejar atent selectat. Imbinarile creeaza un tipar natural

cod	mm	lei
505489	420x280x(H)40	116,99

### PLATOU DE SERVIRE DIN STEJAR, END-GRAIN

- Cu doua fete.
- Realizat prin metoda end-grain: fibrele de stejar sunt lipite impreuna, formand un model elegant de tabla de sah.
- Amplasare verticala a fibrelor de lemn, perpendicular pe suprafata de lucru - durabilitate crescuta, rezistenta la zgarieturi si prevenirea tocirii cutitelor.

cod	mm	lei
505458	325x265x(H)30	145,99
505441	530x325x(H)35	226,99

NOU



505441

**OPTIMA**

- Portelan alb.
- Margini intarite
- Portelan de inalta calitate.
- Rezistenta ridicata la impact si uzura.

**FARFURIE INTINSA**

cod	mm	lei
770849	ø160	12,99
770856	ø210	14,49
770870	ø240	15,99
770887	ø270	20,99
770894	ø300	34,99

**FARFURIE PASTE**

cod	mm	lei
770948	ø260	32,99

**FARFURIE ADANCA**

cod	mm	lei
770863	ø220	15,99

**BOL SUPA**

cod	-	litri	mm	lei
770924	bol supa	0.38		29,99
770931	farfurie		ø170	12,99

**CEASCA SI FARFURIE**

cod	-	litri	mm	lei
770900	bol supa	0.09		9,99
770917	farfurie		ø90	7,49
770962	bol supa	0.23		14,99
770979	farfurie		ø145	9,99

**NOU**
**PLATOU CU MARGINE INALTA OSLO**

- Fabricat din portelan alb vitrat.
- Marginea inalta previne varsarea lichidelor ( sosurilor etc.).
- Sigur pentru utilizarea in cuptorul cu microunde.
- Poate fi spalat in masina de spalat vase.
- Nu este sigur pentru cuptor.

cod	mm	lei
768730	ø200	27,99
768747	ø240	29,99
768754	ø280	43,99



434208

### SUPIERA

- Cu capac si lingura pentru servire

cod	litri	mm	lei
434208	2.7	ø270x(H)175	109,99



432136

### SOSIERA

- Cu picior

cod	litri	mm	lei
432143	0.085	120x72x(H)50	16,99
432006	0.14	135x76x(H)70	17,99
432105	0.23	160x98x(H)90	18,89
432129	0.28	200x100x(H)105	26,69
432136	0.46	240x120x(H)120	30,99



785553



785560



786437

### FARFURIE BARK

- Dreptunghiulara

cod	mm	lei
785546	218x105x(H)23	25,99
785553	352x146x(H)40	49,99

### BOL VANILLA

cod	mm	lei
785560	225x111x(H)62	33,99
785577	290x136x(H)80	59,99

### SOSIERA

cod	mm	lei
786437	180x55x(H)130	30,99



### BOL SUPA LIONHEAD

- Portelan special, cel mai dur tip disponibil in piata
- Rezistenta la uzura si la impact desi este relativ usor
- Alb stralucitor



784761



784730

### BOL SUPA

cod	unitate de comanda	litri	mm	lei
784778	6	0.125	ø90x(H)60	12,99
784761	4	0.25	ø120x(H)78	17,99
784754	4	0.5	ø138x(H)95	28,99

### WAZA NA ZUPE

cod	unitate de comanda	litri	mm	lei
784747	12	1	ø175x(H)120	48,99
784730	8	2	ø215x(H)155	84,99

## VASE DIN PORTELAN PENTRU CUPTOR

- Portelan special, cel mai dur tip disponibil
- Rezistenta la socuri termice, la schimbari extreme de temperatura
- Rezistenta la uzura si la impact desi este relativ usor
- Alb extrem de pur si stralucitor

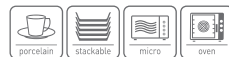

## VAS TAPAS OVAL

- Cu manere



cod	unitate de comanda	mm	lei
784006	6	200x107x(H)30	21,99
784013	6	262x140x(H)33	30,99
784020	3	324x185x(H)38	49,99

## VAS TAPAS RECTANGULAR

- Cu manere



cod	unitate de comanda	mm	lei
784105	6	160x101x(H)45	16,99
784112	4	236x126x(H)48	33,99
784129	3	328x189x(H)58	45,49



786321



786352

## VAS RUSTIC OVAL CUPTOR

cod	unitate de comanda	mm	lei
786321	1	223x132x(H)42	34,99
786338	1	245x145x(H)55	39,99

## VAS RUSTIC PATRAT CUPTOR

cod	unitate de comanda	mm	lei
786352	1	165x165x(H)65	35,99



786369



786307

## VAS RUSTIC DREPTUNGIULAR CUPTOR

cod	unitate de comanda	mm	lei
786369	1	282x192x(H)65	54,99
786376	8	335x232x(H)62	88,99
786383	4	380x260x(H)70	119,99

## VAS RUSTIC ROTUND CUPTOR

cod	unitate de comanda	mm	lei
786307	4	ø100x(H)50	14,99

## VASE DIN PORTELAN PENTRU CUPTOR

- Portelan special, cel mai dur tip disponibil
- Rezistenta la socuri termice, la schimbari extreme de temperatura
- Rezistenta la uzura si la impact desi este relativ usor
- Alb-crem



## VAS ROTUND CUPTOR

cod	unitate de comanda	mm	lei
785904	6	185x152x(H)40	20,99



785904



786499

### FARFURIE COPII „URSULET”

- Ø190 mm fara urechi

cod	unitate de comanda	mm	lei
786499	4	Ø265	48,99



786239



### BOL INGHETATA CLOWN

cod	unitate de comanda	mm	lei
786239	6	226x145x(H)37	39,99

### COVORAS ANTI-ADERENT, MODEL FRUNZA - SET

- Fabricat din PVC (vinil), intr-un model tesut.
- Nu aluneca datorita structurii materialului.
- Flexibile, nu se deformeaza dupa rulare.
- Disponibil in 6 modele elegante (coduri: 597880, 597897, 597910, 597927, 597934, 597941).

cod	culoare	ambalat pe	mm	lei
597910	Gri	6	450x300	34,99

### COVORASE ANTI-ADERENTE - SET

- Fabricat din PVC (vinil), intr-un model tesut.
- Nu aluneca datorita structurii materialului.
- Flexibile, nu se deformeaza dupa rulare.
- Disponibil in 6 modele elegante (coduri: 597880, 597897, 597910, 597927, 597934, 597941).

cod	culoare	ambalat pe	mm	lei
597927	Maro	6	450x300	35,99

### COVORAS ANTI-ADERENT, MODEL GEOMETRIC - SET

- Fabricat din PVC (vinil), intr-un model tesut.
- Nu aluneca datorita structurii materialului.
- Flexibile, nu se deformeaza dupa rulare.
- Disponibil in 6 modele elegante (coduri: 597880, 597897, 597910, 597927, 597934, 597941).

cod	culoare	ambalat pe	mm	lei
597934	Verde	6	450x300	34,99
597941	Argintiu	6	450x300	34,99

### COVORAS ANTI-ADERENT CADRU - SET

- Fabricat din PVC (vinil), intr-un model tesut.
- Nu aluneca datorita structurii materialului.
- Flexibile, nu se deformeaza dupa rulare.
- Disponibil in 6 modele elegante (coduri: 597880, 597897, 597910, 597927, 597934, 597941).

cod	culoare	ambalat pe	mm	lei
597880	Grafit	6	450x300	35,99
597897	Bej	6	450x300	35,99

**NOU**



597910



597927



597934



597941

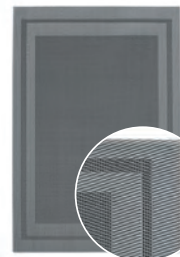

597880



597897







678206



678220

### HARTIE IMPERMEABILA - 500 BUCATI

- Ambalate cate 500 foi

cod	-	mm	lei
678237	alb	250x200	<b>69,99</b>
678220	model bucatar	250x200	<b>99,99</b>
678213	alb	263x380	<b>109,99</b>
678176	model patratele	306x305	<b>149,99</b>
678206	model haos in bucatarie	258x425	<b>139,99</b>

### HARTIE IMPERMEABILA, REZISTENTA LA GRASIME - 500 BUCATI

- Set de 500 bucati

cod	-	mm	lei
678145	model haos in bucatarie	420x275	<b>209,99</b>
678152	model patratele	420x275	<b>219,99</b>

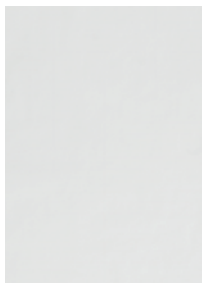

678237

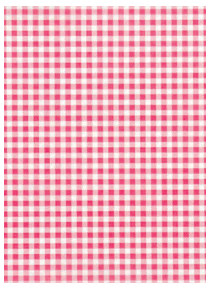

678152



678121

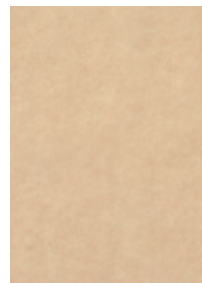

678138

### HARTIE IMPERMEABILA

- Ambalate cate 500 foi

cod	culoare	mm	lei
678138	Bej	200x250	<b>59,99</b>
678114	Bej	250x350	<b>95,99</b>
678121	Ziar	200x250	<b>69,99</b>
678107	Ziar	250x350	<b>114,99</b>

### HARTIE IMPERMEABILA, REZISTENTA LA GRASIME PRE-MODELATA - 150 BUCATI

- Preformate sub forma de cos.
- Ilustratii cu diverse preparate.
- Ambalat la 150 de bucati.

cod	mm	lei
678190	160x160x(H)50	<b>64,99</b>



678190

### VASE DIN PORTELAN - TAPAS

- Portelan special, cel mai dur tip disponibil in piata
- Rezistenta la uzura si la impact desi este relativ usor
- Alb stralucitor



784426

#### VAS TAPAS PLATO - 6 BUCATI

cod	mm	lei
784426	ø100x(H)25	43,99



784327

#### VAS TAPAS CUADRADO - 6 BUCATI

cod	mm	lei
784327	80x80x(H)35	51,99



784365

#### VAS TAPAS REDONDO - 6 BUCATI

cod	mm	lei
784365	ø75x(H)30	42,99



784433

#### VAS TAPAS LEON - 6 BUCATI

cod	mm	lei
784433	ø55x(H)45	49,99



784334

#### VAS TAPAS CONCHA - 6 BUCATI

cod	mm	lei
784334	90x50x(H)20	34,99



784419

#### VAS TAPAS CUADRADO - 6 BUCATI

cod	mm	lei
784419	59x59x(H)37	35,79



784389

#### VAS TAPAS CACEROLE - 6 BUCATI

cod	mm	lei
784389	ø60x(H)25	38,99



784372

#### VAS TAPAS HUEVO - 6 BUCATI

cod	mm	lei
784372	ø65x(H)15	39,99



784396

#### VAS TAPAS TRIANGOLO - 6 BUCATI

cod	mm	lei
784396	100x100x(H)25	49,99



785324

#### VAS TAPAS CUCHARA - 6 BUCATI

cod	mm	lei
785324	130x43x(H)26	44,99

## ARTICOLE PREZENTARE



Vezi filmul



564509

### MINI-TIGAIE SOS LITTLE CHEF

- Articole de prezentare din melamina, in forma de vase de gatit

cod	mm	lei
564509	162x121x(H)30	15,49



564516

### MINI-TIGAIE GRILL LITTLE CHEF

- Articole de prezentare din melamina, in forma de vase de gatit

cod	mm	lei
564516	320x162x(H)20	44,99



564523

### MINI-TIGAIE ROTUNDA LITTLE CHEF

- Articole de prezentare din melamina, in forma de vase de gatit

cod	mm	lei
564523	150x115x(H)37	15,99
564530	189x147x(H)37	23,99



564554

### MINI-TIGAIE OVALA LITTLE CHEF

- Articole de prezentare din melamina, in forma de vase de gatit

cod	mm	lei
564547	155x80x(H)37	11,99
564554	263x140x(H)37	31,99



## ARTICOLE PREZENTARE

426425



426432



426449

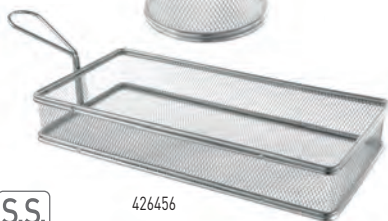

426456



Vezi filmul

425619



425626



425633



425657



### COSURI TIP FRITEUZA - PENTRU SERVIRE

cod	mm	lei
426449	90x90x(H)90	24,99
426425	100x80x(H)75	26,89
426432	125x100x(H)85	28,99
426456	255x135x(H)45	43,99

### COSURI TIP FRITEUZA - PENTRU SERVIRE

- Finisat cu un strat negru mat.

cod	mm	lei
425633	90x90x(H)90	33,99
425619	100x80x(H)75	34,99
425626	125x100x(H)85	42,39
425657	255x135x(H)45	49,99



425688

### COSURI TIP FRITEUZA - PENTRU SERVIRE

cod	mm	lei
425664	105x90x(H)60	23,99
425688	130x115x(H)80	34,99





### MINI-COS NEGRU PENTRU SERVIRE, STOCABIL

- Finisat cu un strat negru mat.

cod	mm	lei
425671	105x90x(H)60	33,99
425695	130x115x(H)80	33,59



425671

425695



630914

### SUPORT PUNGA CHIPS-URI

- Suport din sarma neagra, cu spatii pentru bol sos  
- Potrivit pentru vas ramekin melamina 80 ml (561713), nu este inclus

cod	mm	lei
630914	210x110x(H)172	36,99



630938

### SUPORT PUNGA CHIPS-URI

- Suport din sarma neagra, potrivit pentru 1 punji chips-uri

cod	mm	lei
630938	ø115x(H)172	28,99



426494

### COS PENTRU CHIPS-URI

- Suport din sarma neagra

cod	mm	lei
426494	ø115x(H)100	25,99



630907

### SUPORT PUNGA CHIPS-URI

- Suport din sarma neagra

cod	mm	lei
630907	ø110x(H)175	32,99



## EMAILAT

- Confectionata din otel emailat alb, cu o margine albastra.
- Email de inalta calitate, rezistent la abraziune.
- Poate fi stivuit pentru a eficientiza spatiul
- Potrivita pentru masina de spalat vase.
- Se poate utiliza in cuptor.
- **NOTA:** Nu este sigur pentru cuptorul cu microunde.



621202



621226



621257

## BOL RECTANGULAR

- Alimentele/deserturile pot fi preparate in acest vas

cod	mm	lei
621219	215x160	29,99
621202	175x130	22,99

## FARFURIE INTINSA

cod	mm	lei
621226	ø200	18,99
621233	ø240	23,29

## FARFURIE ADANCA

cod	mm	lei
621240	ø180	19,99
621257	ø200	24,99
621264	ø220	23,99
621271	ø240	29,99



621288

## BOL SALATA

cod	mm	lei
621288	ø160x(H)75	23,99



621295

## CANA

cod	litri	mm	lei
621295	0.36	ø90x(H)80	17,99
621301	0.52	ø100x(H)90	20,99



621318

## CEASCA

cod	litri	mm	lei
621318	0.12	ø70x(H)50	14,99



621332

## PAHAR

cod	litri	mm	lei
621325	0.3	ø90x(H)90	19,29
621332	0.4	ø90x(H)120	24,99





625804



625705

**OALA SUPA & SOS - CU CAPAC**

- Emailata
- Margine din otel inoxidabil
- Capac scund

cod	-	litri	mm	lei
625804	Albastra	0.5	ø115x(H)95	49,99
625705	Neagra	0.65	ø135x(H)110	44,99



622858

**BOL EMAILAT PENTRU PAELLA**

- Model adanc
- Strat din otel emailat

cod	mm	lei
622810	ø145x(H)40	34,99
622827	ø170x(H)40	39,99
622834	ø185x(H)43	35,99
622841	ø205x(H)57	37,99
622858	ø245x(H)70	54,99



622742

**TIGAIE EMAILATA PAELLA**

- Cu 2 manere
- Strat din otel emailat

cod	mm	lei
622704	ø100x(H)20	29,99
622711	ø120x(H)25	32,99
622728	ø150x(H)27	33,99
622735	ø200x(H)36	40,99
622742	ø240x(H)40	44,99



Preturile nu includ TVA

475





426371

426364

**RECIPIENT MINI - SERVIRE SNACKS**

cod	mm	lei
426364	ø87x(H)93	17,99
426371	ø125x(H)127	24,99



426463

**RECIPIENT MINI - SERVIRE SNACKS**

cod	mm	lei
426463	ø45x(H)50	14,99
426470	ø70x(H)100	21,99



426395

**STRECURATOARE DE GUSTARI IN MINIATURA**

cod	mm	lei
426395	ø130x(H)64	15,99



426487

**TAVA SNACKS**

cod	mm	lei
426487	196x95x(H)70	23,99





Vezi filmul



607039

### MINI-TIGAIIE PENTRU SOS

- Fabricate din material 3-ply (cupru/aluminiu/otel inoxidabil) cu grosime 2,5 mm
- Manerul este fixat cu nituri

cod	litri	mm	lei
607015	0.05	ø50x(H)30	69,99
607022	0.16	ø75x(H)40	77,99
607039	0.26	ø85x(H)50	99,99



607046

### MINI-TIGAIIE PENTRU PRAJIT

- Fabricata din material 3-ply (cupru/aluminiu/otel inoxidabil) cu grosime 2,5 mm
- Manerul este fixat cu nituri

cod	mm	lei
607046	ø120x(H)30	149,99



## GALETI PENTRU TACAMURI

- Fabricat din tabla de otel galvanizat, acest lucru creeaza un aspect rustic.
- Otelul galvanizat nu este destinat pentru contactul cu alimentele, utilizati linia de galeti cu foile de hartie rezistenta la grasimi atunci cand se foloseste pentru servirea hranei.



425954



425923

## GALEATA DUBLA CU MANER

- Manerul este fabricat din lemn

cod	mm	lei
425954	250x125x(H)105	49,99

## GALEATA CU MANER

cod	mm	lei
425909	ø70x(H)65	7,99
425916	ø100x(H)90	15,99
425923	ø120x(H)105	17,99
425985	ø160x(H)140	19,99



425992



425978

## FRAPIERA PENTRU PETRECERI

cod	mm	lei
425992	400x330x(H)220	77,79

## GALEATA PENTRU TACAMURI SI SERVETELE

- Cu maner care este prevazut cu prindere din lemn.

cod	mm	lei
425978	245x180x(H)130	49,99



783177

**RAMEKIN**

- Striat

cod	unitate de comanda	mm	lei
783153	12	ø70x(H)35	<b>12,99</b>
783160	6	ø90x(H)48	<b>13,99</b>
783627	6	ø100x(H)25	<b>13,99</b>
783177	6	ø120x(H)55	<b>19,99</b>

565605



565612

**RAMEKIN - 12 BUCATI**

cod	ambalat pe	culoare	litri	mm	lei
565605	12	Negru	0.045	ø60x(H)35	<b>34,99</b>
565612	12	Ivoire	0.045	ø60x(H)35	<b>34,99</b>



564561

**FARFURIE UNT & SOS - 3 BUCATI**

cod	ambalat pe	culoare	mm	lei
564561	3	Negru	ø80x(H)30	<b>24,49</b>

**RAMEKIN - 12 BUC.**

cod	litri	mm	lei
400029	0.07	ø62x(H)40	<b>34,99</b>
400012	0.045	ø62x(H)24	<b>39,99</b>
400036	0.115	ø73x(H)47	<b>44,09</b>
400043	0.175	ø85x(H)52	<b>58,99</b>
400050	0.23	ø93x(H)58	<b>75,99</b>
400067	0.34	ø100x(H)75	<b>74,99</b>

561720

**RAMEKIN**

- Pentru utilizare in baruri si restaurante
- Conceput pentru a servi sosuri si sosuri
- Fabricat din melamina
- Cu caneluri decorative
- Greutate usoara
- Rezistenta ridicata la deteriorari mecanice
- Potrivit pentru spalare in masina de spalat vase
- NOTA: Nu este potrivit pentru utilizare intr-un cuptor cu microunde

cod	-	unitate de comanda	mm	lei
561492	35 ml	1	ø60x(H)25	<b>3,99</b>
565643	35 ml	4	ø60x(H)25	<b>13,99</b>
561706	50 ml	1	ø70x(H)35	<b>12,99</b>
565650	50 ml	4	ø70x(H)35	<b>24,99</b>
561713	80 ml	1	ø80x(H)40	<b>9,99</b>
561720	100 ml	1	ø85x(H)45	<b>10,99</b>

564592

**BOL OBLIC VELOCITY**

cod	mm	lei
564578	70x70x(H)60	<b>9,99</b>
564585	97x97x(H)80	<b>14,99</b>
564592	110x110x(H)100	<b>19,99</b>

400067





426920



426999

**COS PAINE ROTUND**

- Rezistent la rupere, cu cadru de sarma din otel inoxidabil
- Disponibil in mai multe culori.

cod	culoare	mm	lei
426920	Bej	ø400x(H)90	<b>79,99</b>
426999	Maro	ø400x(H)90	<b>79,99</b>



426289

**COS BRUTARIE OVAL**

cod	culoare	mm	lei
426777	Negru	190x120x(H)60	<b>26,99</b>
426760	Gri	190x120x(H)60	<b>26,99</b>
426623	Negru	250x190x(H)65	<b>32,99</b>
426616	Gri	250x190x(H)65	<b>32,99</b>
426654	Negru	320x230x(H)70	<b>49,99</b>
426647	Gri	320x230x(H)70	<b>49,99</b>

**CAPAC ROLL TOP PENTRU COSUL DE PAINE**

- Se potriveste cu cosul de paine 426920, 426982 & 426999.
- Cu deschidere usoara.

cod	mm	lei
426289	ø405x(H)230	<b>159,99</b>



426784

426647

426654

426760

426616

426777

426623

426791

**COS BRUTARIE**

cod	culoare	mm	lei
426784	Gri	190x130x(H)60	<b>26,99</b>
426791	Negru	190x130x(H)60	<b>26,99</b>



426562



426586



426593

**COS BRUTARIE ROTUND**

cod	culoare	mm	lei
426562	Gri	ø310x(H)120	<b>59,99</b>
426586	Gri	ø370x(H)120	<b>79,99</b>
426593	Negru	ø370x(H)120	<b>79,99</b>

**COS**

cod	mm	lei
426814	ø250x(H)180	<b>34,99</b>
426821	ø250x(H)265	<b>39,99</b>



426821



426814



426524



426661



426678

**COS BRUTARIE CU RAMA DIN OTEL INOXIDABIL**

cod	culoare	mm	lei
426524	Gri	400x300x(H)50	<b>79,99</b>

**COS BRUTARIE DREPTUNGIULAR**

cod	culoare	mm	lei
426678	Negru	400x300x(H)120	<b>89,99</b>
426661	Gri	400x300x(H)120	<b>89,99</b>





### COSURI IMPLETITE

cod		mm	lei
426258	rotund	200x200x(H)65	<b>18,99</b>
426234	oval	225x130x(H)55	<b>16,99</b>
426265	oval	320x230x(H)55	<b>34,99</b>
426227	patrat	190x190x(H)80	<b>19,99</b>
426241	dreptunghiular	225x150x(H)65	<b>16,99</b>



### COS DE BRUTARIE CU PUNGA

- Finisat cu un strat negru mat.
- Cu un cos interior pentru paine, din material.
- Cosul textil poate fi spalat la masina.

cod	mm	lei
427118	220x220x(H)80	<b>59,99</b>
427125	250x160x(H)75	<b>69,99</b>
427149	190x190x(H)100	<b>79,99</b>
427132	250x180x(H)85	<b>89,99</b>



426067



426074



426043

### COS TACAMURI

- Cu 4 compartimente.



cod	culoare	mm	lei
426074	Negru	260x180x(H)150	<b>89,99</b>
426067	Gri	260x180x(H)150	<b>89,99</b>

### COS SNACK



cod	culoare	mm	lei
426043	Gri	ø130x(H)110	<b>29,99</b>



426081



426098



### COS TACAMURI

cod	culoare	mm	lei
426098	Negru	270x100x(H)45	<b>29,99</b>
426081	Gri	270x100x(H)45	<b>29,99</b>



426197

426210



### COS TACAMURI

cod	culoare	mm	lei
426210	Negru	ø100x(H)120	<b>24,99</b>
426197	Gri	ø100x(H)120	<b>24,99</b>

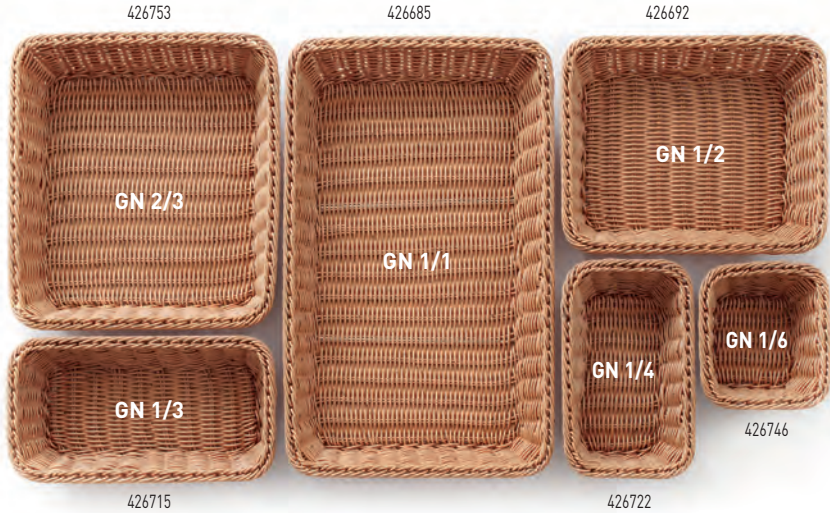

### COS BRUTARIE DIMENSIUNE GN

- Brat din otel inoxidabil intarit.

cod		mm	lei
426746	GN 1/6	176x162x(H)65	28,79
426722	GN 1/4	265x162x(H)65	35,89
426715	GN 1/3	325x176x(H)65	49,99
426692	GN 1/2	325x265x(H)65	54,99
426753	GN 2/3	325x354x(H)65	64,99
426685	GN 1/1	530x325x(H)65	99,99



426722

426715



**NOU**

### COS PREZENTARE PAINE

- Cos de dimensiuni mari - perfect pentru afisarea painii si a altor produse coapte in brutarii, magazine alimentare si bufete.
- Fabricat din polirattan, intarit cu un cadru din otel inoxidabil.
- Potrivit pentru masina de spalat vase.

cod	mm	lei
427248	595x395x(H)105	150,99
427231	295x395x(H)105	104,99



427248



427231



## COSURI



561102



Vezi filmul



561201

### COS PAINÉ GN 1/1

- Brat din otel inoxidabil intarit.

cod	mm	lei
561102	530x320x(H)90	69,99



561003

### COS PAINÉ OVAL

- Brat din otel inoxidabil intarit.

cod	mm	lei
561003	380x270x(H)90	48,99

### DISPLAY COS PAINÉ GN 1/2

- Set de 2 cosuri cu suport cromat.
- Cosuri armate cu un cadru din otel inoxidabil.
- Dimensiuni cos: 360x280x(H)90 mm.
- Este interzisa spalarea suportului la masina de spalat vase.

cod	mm	lei
561201	360x280x(H)290	129,99



426968



### COS CU CAPAC ROLLTOP

- Cos din polipropilena dura (polyrattan)
- Capac rolltop din policarbonat

cod	GN	mm	lei
426968	GN 2/3	365x335x(H)245	284,99



426517



### COS BAGHETE

cod	mm	lei
426517	305x320x(H)350	199,99





### COS DE PAINE OVAL

- Destinat restaurantelor de tip fast-food
- Fabricat din polipropilena, usor de curatat
- Foarte usor
- Cosurile sunt stivuibile
- Potrivit pentru spalarea in masinile de spalat vase
- Set de 6
- Disponibil in 3 culori

cod	ambalat pe	culoare	mm	lei
426890	6	Negru	275x175x(H)38	28,99
426296	6	Maro	275x175x(H)38	28,99
426319	6	Rosu	275x175x(H)38	28,99



### COSURI PAINE



### COS DIN HARTIE

- Fabricat din hartie kraft lavabila potrivita pentru produse alimentare

cod	culoare	mm	lei
429228	Bej	170x170x(H)150	39,99
429211	Negru	170x170x(H)150	36,99

### COS ROTUND PENTRU PAINE

- Confectionate din bumbac rezistent
- Disponibile in combinatiile de culori gri/bej si gri/gri inchis

cod	culoare	mm	lei
429006	Bej	ø150x(H)150	17,99
429013	Gri inchis	ø150x(H)150	17,99
429020	Bej	ø200x(H)200	22,99
429037	Gri inchis	ø200x(H)200	22,99
429044	Bej	ø250x(H)160	24,99
429051	Gri inchis	ø250x(H)160	24,99



## COSURI

- Polyrotan



### COS PAINE - OVAL

cod	mm	lei
426500	225x130x(H)55	<b>9,99</b>

### COS PAINE - DREPTUNGIULAR

cod	mm	lei
426807	225x150x(H)65	<b>13,99</b>

### COS PAINE - ROTUND

cod	mm	lei
426609	ø200x(H)65	<b>11,99</b>

### COS PAINE - OVAL

cod	mm	lei
426708	225x110x(H)60	<b>9,99</b>

### COS PAINE - OVAL

cod	mm	lei
426906	375x140x(H)70	<b>19,99</b>



425800



425602

### COS PAINE PITTA - ROTUND

- Nu este destinat contactului cu alimentele, acoperiti cosul cu o foile de hartie rezistenta la grasimi cand il folositi pentru servirea hranei.

cod	mm	lei
425701	ø150x(H)38	<b>7,99</b>
425800	ø200x(H)50	<b>11,99</b>

### COS PAINE PITTA - OVAL

- Nu este destinat contactului cu alimentele, acoperiti cosul cu o foile de hartie rezistenta la grasimi cand il folositi pentru servirea hranei.

cod	mm	lei
425503	195x140	<b>10,99</b>
425602	255x190	<b>12,99</b>

## COSURI SARMA



425879

### COS DECO OVAL DIN SARMA

- Cu margine decorativa.
- Finisat cu un strat negru mat.

cod	mm	lei
425879	255x160x(H)80	<b>39,99</b>



425855

### COS DECO DREPTUNGIULAR DIN SARMA

- Cu margine decorativa.
- Finisat cu un strat negru mat.

cod	mm	lei
425855	230x150x(H)80	<b>33,99</b>



425886

### COS DECO LUNG DIN SARMA

- Cu margine decorativa.
- Finisat cu un strat negru mat.

cod	mm	lei
425886	385x160x(H)80	<b>44,99</b>



425558

### COS SERVIRE NEGRU

- Finisat cu un strat negru mat.

cod	mm	lei
425558	295x220x(H)60	<b>32,99</b>



425565

### COS SERVIRE

cod	mm	lei
425565	310x125x(H)55	<b>22,99</b>



426418

### COS FRUCTE

- Sarmе otel cromat



cod	mm	lei
426418	ø215x(H)205	41,49



427187

### COS NEGRU PENTRU FRUCTE

- Finisat cu un strat negru mat.



cod	mm	lei
427187	ø230x(H)250	69,99



### COS NEGRU PENTRU FRUCTE

- Finisat cu un strat negru mat.

cod	mm	lei
427095	ø150x(H)80	32,99
427088	ø280x(H)130	69,99
427071	ø300x(H)250	79,99



427088



427071



427095

426265

426241



426227

426258

426234



### COSURI IMPLETITE

cod		mm	lei
426258	rotund	200x200x(H)65	18,99
426234	oval	225x130x(H)55	16,99
426265	oval	320x230x(H)55	34,99
426227	patrat	190x190x(H)80	19,99
426241	dreptunghiular	225x150x(H)65	16,99



449615



### CANA VACUUM

- Capacul de etansare se fixeaza cu ajutorul butonului pentru turnare.
- Perete dublu cu interior de sticla.

cod	litri	mm	lei
449615	1	ø110xH289	69,99



Preturile nu includ TVA

 HENDI

489



## CANA VACUUM

- Pereti dubli din otel inoxidabil
- Structura fara sudura
- Izolare vacuum
- Capac si maner din metal cromat
- Valoare mare a capacitatii de izolare



445839



446706



446720



### CANA VACUUM

cod	litri	mm	lei
445815	0.6	ø120x(H)168	199,99
445822	1	ø136x(H)188	225,99
445839	1.5	ø136x(H)258	239,99

### CANA VACUUM

- Pereti dubli din otel inoxidabil
- Cu sistem apasare capac, negru
- Partea superioara si capacul din polipropilena

cod	litri	mm	lei
446607	1.5	ø145x(H)230	84,99
446508	1	ø145x(H)205	78,99
446706	2	ø145x(H)260	91,99

### CANA VACUUM

- Pereti dubli din otel inoxidabil
- Cu sistem apasare capac, galben
- Partea superioara si capacul din polipropilena

cod	litri	mm	lei
446522	1	ø145x(H)205	78,99
446621	1.5	ø145x(H)230	84,99
446720	2	ø145x(H)260	91,99



449608



### CANA VACUUM CU RECIPIENT DIN STICLA IN INTERIOR

cod	litri	mm	lei
449608	1	ø140x(H)268	55,99



Vezi filmul



448908

445877



### TERMOS

- Manta din otel inoxidabil.
- Robinet tip presa.
- Interior realizat din otel inoxidabil.

cod	litri	mm	lei
448908	2.2	ø150x(H)340	119,99

### TERMOS - 3L

- Perete dublu vacuum si cap PP
- Baza rotativa
- Maneta din aliaj cu zinc pentru o rezistenta superioara
- Capacul se deschide la 125 grade si este detasabil pentru curatare
- Maner solid

cod	litri	mm	lei
445877	3	ø171x(H)373	289,99





451526

**CANI CU INTREBUINTARI MULTIPLE**

cod	litri	mm	lei
451502	0.35	ø76x(H)93	34,99
451519	0.6	ø90x(H)112	44,99
451526	0.9	ø102x(H)125	51,99
451533	1.5	ø112x(H)161	73,99



451045

**CANA PENTRU LAPTE CU MARGINEA IN FORMA DE V AJUTA LA TURNAREA LICHIDULUI CULOARE NEGRU MAT**

- Fabricat din otel inoxidabil foarte gros, ajuta la mentinerea continutului fierbinte.
- Gura in forma de V ofera un control suplimentar in timpul turnarii.

cod	litri	mm	lei
451045	0.7	ø84x(H)130	89,99



451014

**CANA PENTRU LAPTE CU GURA IN FORMA DE V**

- Fabricat din otel inoxidabil
- Pereti de 1 mm grosime pentru a mentine temperatura lichidului
- Margine in forma de V pentru o turnare precisa
- Se poate spala in masina de spalat vase

cod	litri	mm	lei
451038	0.35	ø65x(H)99	49,99
451021	0.45	ø75x(H)111	62,99
451014	0.7	ø84x(H)130	69,99



458198

**CANA LAPTE NEAGRA**

- Fabricat din otel inoxidabil acoperit cu un strat negru anti-lipire.

cod	litri	mm	lei
458198	0.6	ø90x(H)112	69,99



451106

**CANA PENTRU LAPTE/APA**

- Model simplu

cod	litri	mm	lei
451007	0.35	ø85x(H)110	32,99
451106	0.75	ø100x(H)120	42,99



450505

**LATIERA DIN INOX**

- Fabricat din otel inoxidabil.
- Creati modele cu o margine special conceputa pentru lucrari curate si eficiente.
- Poate fi spalat in masina de spalat vase.
- Disponibile in mai multe dimensiuni [coduri: 450109, 450208, 450307, 450406, 450505].

cod	litri	mm	lei
450109	0.03	ø35x(H)35	10,49
450307	0.07	ø50x(H)55	13,99
450406	0.12	ø60x(H)60	17,99

**NOU**

451052

**LATIERA CU MASURA**

- Fabricat din otel inoxidabil.
- Creati modele cu o margine special conceputa pentru lucrari curate si eficiente.
- Poate fi spalat in masina de spalat vase.
- Disponibile in mai multe dimensiuni [coduri: 450109, 450208, 450307, 450406, 450505].

cod	litri	mm	lei
451052	0.55	130x77x(H)115	44,99

**CAFETIERA/CEAINIC CU CAPAC**

- Cu capac rabatabil
- Model simplu

cod	litri	mm	lei
453001	0.2	ø74x(H)95	35,99
453100	0.3	ø74x(H)123	39,99
453209	0.6	ø97x(H)142	58,99
453308	0.9	ø120x(H)158	79,99
453407	1.4	ø126x(H)185	87,99



453209





**570807**

**STRECURATOARE CEAI - CU MANER**  
**CE SE POATE AGATA**  
 - Pentru plante si ceai  
 - Cu maner ce se poate agata

S.S.  
stainless steel

cod	mm	lei
570807	ø45x165	11,99

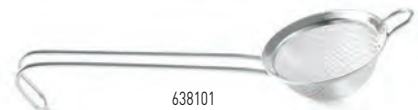

**638101**

**STRECURATOARE CEAI & PLANTE**  
 - Pentru plante si ceai  
 - Cu maner sarma

18/10  
stainless steel

cod	mm	lei
638101	ø70x225	11,99



**523629**

**CLESTI CUBURI ZAHAR - 2 BUCATI**

S.S.  
stainless steel

cod	ambalat pe	mm	lei
523629	2	[L]160	17,99



**452325**

**VAS PENTRU ZAHAR/FRISCA**

S.S.  
stainless steel

cod	ambalat pe	mm	lei
452714	6	ø65x(H)20	21,99
452325	4	ø100x(H)20	24,99



**452103**

**ZAHARNITA**  
 - Cu capac rabatabil

S.S.  
stainless steel

cod	litri	mm	lei
452103	0.3	ø85x(H)80	29,99



**452202**

**ZAHARNITA**  
 - Fara capac

S.S.  
stainless steel

cod	litri	mm	lei
452202	0.3	ø85x(H)65	22,99



**440704**

**COS GUNOI MASA**  
 - Container din otel inoxidabil  
 - Capac rabatabil din plastic negru

S.S.  
stainless steel

wash

cod	mm	lei
440704	ø120x(H)165	59,99



**440711**

**COS GUNOI PENTRU MASA**  
 - Capac basculant din otel inoxidabil,  
 marginea din plastic negru

18/0  
stainless steel

cod	mm	lei
440711	ø95x(H)130	39,99



**421574**

**SUPORT PENTRU TACAMURI**  
 - Fabricat negru fabricat din melamina

M  
melamina

poate fi folosit ca suport pentru tacamuri

cod	culoare	mm	lei
421574	Negru	ø130x(H)160	43,99



456514

### CUTIE DE CEAI

- Cutie realizata din lemn, cu o nuanta deschisa naturala.
- Capac: un cadru din lemn cu o fereastra acrilica, pe balamale, pe balamale, cu deschidere in partea superioara.
- 12 compartiment, fiecare poate depozita pana la 12 pliculete de ceai.



cod	mm	lei
456514	300x280x(H)90	166,99



400203

18/0  
stainless steel

### TAVA SERVIRE

cod	mm	lei
400203	205x155	18,99



441107

### CUPA INGHEATATA

- Cu picior

S.S.  
stainless steel

cod	mm	lei
441107	ø90x(H)50	12,99



595008

### SONERIE RECEPTIE

- Otel cromat cu baza din metal

Cr  
chrome plated

cod	mm	lei
595008	ø85x(H)57	22,99



444023

18/0  
stainless steel

### CLEMA FATA DE MASA - 4 BUCATI

cod	ambalat pe	mm	lei
444023	4	50x10x(H)40	15,99



428511

### SUPORT SERVETELE

- Aspect mat

S.S.  
stainless steel

cod	mm	lei
428511	170x30x(H)70	24,99



428528

### SUPORT SERVETELE

- Cadre din otel cromat

Cr  
chrome plated

cod	mm	lei
428528	190x190x(H)65	34,49



427163

### SUPORT NEGRU PENTRU SERVETELE

- Finisat cu un strat negru mat.

cod	mm	lei
427156	155x160	36,99
427163	205x210	39,99



### CLIPBOARD PENTRU MENIU

- Fabricat din lemn durabil cu mecanism de prindere metalic.
- Disponibil in mai multe dimensiuni.

cod	mm	lei
664179	125x180	7,99
664162	185x245	9,99
664155	240x330	12,99



664179



664162



664155



664278

### MARKERE PENTRU TABLA 3 MM

- 8 markere cu varf conic, latime scris 3 mm

cod	-	lei
664278	1 alb, 1 rosu, 1 albastru, 1 verde, 1 galben, 1 violet, 1 portocaliu, 1 roz	44,99



664209



664216

### MARKERE PENTRU TABLA 6 MM

- Pentru tabla stradala
- Varf conic / oblic cu doua fete
- Grosimea liniei: 2-6 mm

cod	-	lei
664292	2 albe, 1 roz, 1 galben si 1 bronz	39,99
664216	1 roz, 1 verde, 1 albastru si 2 albe	39,99
664209	5 albe	39,99



664339



664223

### MARKERE PENTRU TABLA 15 MM

- Pentru tabla stradala
- Varf larg, plat
- Grosimea liniei: 15 mm
- Un set de markere in 3 culori: alb, portocaliu, galben

cod	-	lei
664339	1 alb, 1 portocaliu si 1 galben	29,99
664223	3 albe	29,99



664285

### MARKERE PENTRU TABLA 1 MM

- Pentru tabla stradala
- Varf rotund
- Grosimea liniei: 1 mm

cod	-	lei
664285	3 albe, 1 roz, 1 galben si 1 bronz	29,99

663547



### SEMN MASA „REZERVAT”

- Alb-negru
- Ambele fete scrise

cod	-	mm	lei
663547	rezervat	130x30x(H)38	7,99

664308



### SEMN DE MASA RESERVED

- Fabricat din lemn durabil.

cod	-	mm	lei
664308	„reserved”	152x44x(H)44	13,99





### SEMN MASA - NUMERE

- Seturi de numere multiple
- Set de 12 numere

cod	-	mm	lei
663844	Numere 1-12	50x35x(H)40	49,99
663851	Numere 13-24	50x35x(H)40	49,99
663868	Numere 25-36	50x35x(H)40	49,99
663875	Numere 37-48	50x35x(H)40	49,99
663882	Numere 49-60	50x35x(H)40	49,99
663899	Numere 61-72	50x35x(H)40	49,99



### SEMN USA

- Cu banda autoadeziva

cod	-	mm	lei
663615	Femei	ø75	11,99
663622	Toaleta	ø75	11,99
663639	Fumatul interzis	ø75	12,99
663646	Persoane in scaun rulant	ø75	12,99



663615

663622



663639

663646

663653



### SEMN PERETE

- Cu banda autoadeziva

cod	-	mm	lei
663790	Nefumatori	ø75	11,99



663820



663806



### SEMN MASA „FUMATUL INTERZIS”

- Scris pe ambele fețe

cod	mm	lei
663660	50x35x(H)40	10,99



663660





441466

**SUPPORT OU - 6 BUCATI**

- Model jos



cod	mm	lei
441466	ø85x(H)15	39,99



441367

**SUPPORT OU - 6 BUCATI**

- Cu picior



cod	mm	lei
441367	ø50x(H)45	29,99



441503

**LINGURITA OU - 6 BUCATI**

- Plastic alb



cod	lei
441503	11,99



513729



**SUPPORT PENTRU COMENZI**

cod	mm	lei
513729	ø80x(H)150	22,99



665510

**SUPPORT MENIU**

cod	mm	lei
665503	ø75x(H)100	26,99
665510	ø75x(H)200	35,99



595305

**SUPPORT MENIU - 2 BUCATI**

- Cu clema prindere



cod	mm	lei
595305	ø40x(H)104	34,99

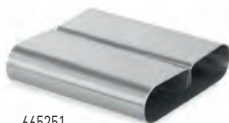

665251



**SUPPORT MENIU PENTRU MASA - 6 BUCATI**

- Fara meniu

cod	ambalat pe	mm	lei
665251	6	80x77x(H)18	89,99



595206

**CLIPS NOTA - 3 BUCATI**

- Cu clema prindere



cod	ambalat pe	mm	lei
595206	3	152x110	56,99



664186

### CUTIE PENTRU TACAMURI

- Fabricat din lemn rezistent.

cod	mm	lei
664186	80x80x(H)95	27,99



664315

### CUTIE DE TACAMURI

- Fabricat din lemn rezistent.  
- Are compartimente multiple, cu maner.

cod	mm	lei
664315	190x160x(H)200	59,99



664148

### CUTIE PENTRU MENIURI

- Cutie din lemn cu tabla neagra integrata pe doua laturi.  
- Cutia are 4 compartimente.

cod	mm	lei
664148	210x150x(H)150	81,99



425770

### SUPPORT PENTRU CONDIMENTE DREPTUNGIULAR

- Suport din fire negre.

cod	mm	lei
425770	205x90x(H)180	29,99



425787

### SUPPORT PENTRU CONDIMENTE ROTUND

- Suport din fire negre.

cod	mm	lei
425787	ø165x(H)215	34,99



427170

### SUPPORT NEGRU PENTRU CONDIMENTE

- Finisat cu un strat negru mat.

cod	mm	lei
427170	135x65x(H)200	24,99



427064



427057



427040

### CUTIE NEAGRA PENTRU MASA

- Maner cu maner din lemn.  
- Finisat cu un strat negru, mat.

cod	mm	lei
427064	140x105x(H)190	79,99
427057	170x130x(H)160	79,99
427040	230x100x(H)240	79,99



**RASNITE DE SARE SI PIPER**

**RASNITA PIPER DIN LEMN**

- Corp din lemn de cauciuc – usor, dar rezistent.
- Mecanism de macinare, fabricat din otel inoxidabil, manual si reglabil cu un buton rotativ.
- Capac protejat impotriva caderii cu un buton cu surub.
- Buton cu litera P” imprimata – pentru marcarea continutului.
- Disponibil in mai multe culori: lemn inchis, lemn deschis, lemn lacuit negru (finis lucios)

cod	culoare	mm	lei
469613	Alb	ø50x(H)113	29,99
469606	Alb	ø55x(H)215	44,99
469590	Alb	ø60x(H)315	69,99
469583	Alb	ø65x(H)415	79,99
469699	Lemn deschis	ø50x(H)113	29,99
469712	Lemn deschis	ø57x(H)165	34,99
469736	Lemn deschis	ø57x(H)215	41,99
469750	Lemn deschis	ø60x(H)315	59,99
469774	Lemn inchis	ø50x(H)113	29,99
469798	Lemn inchis	ø57x(H)165	34,99
469811	Lemn inchis	ø57x(H)215	39,99
469835	Lemn inchis	ø60x(H)315	54,99

**RASNITA PENTRU SARE DIN LEMN**

- Corp din lemn de cauciuc – usor, dar rezistent.
- Mecanism de macinare ceramic – necoroziv (adevat pentru sare), manual si ajustabil cu un buton.
- Capac protejat impotriva caderii cu un buton cu surub.
- Buton cu litera S” imprimata – pentru marcarea continutului.
- Disponibil in mai multe culori: lemn inchis, lemn deschis, lemn lacuit alb (finis lucios)

cod	culoare	mm	lei
469576	Negru	ø50x(H)113	29,99
469569	Negru	ø55x(H)215	55,99
469552	Negru	ø60x(H)315	59,99
469545	Negru	ø65x(H)415	79,99
469682	Lemn deschis	ø50x(H)113	31,99
469705	Lemn deschis	ø57x(H)165	34,99
469729	Lemn deschis	ø57x(H)215	39,99
469743	Lemn deschis	ø60x(H)315	48,99
469767	Lemn inchis	ø50x(H)113	32,99
469781	Lemn inchis	ø57x(H)165	34,99
469804	Lemn inchis	ø57x(H)215	43,99
469828	Lemn inchis	ø60x(H)315	59,99



Mecanism din inox de maruntire

Mecanism ceramic de maruntire



469682  
469699

469705  
469712

469729  
469736

469743  
469750

469767  
469774

469781  
469798

469804  
469811

469828  
469835



### RASNITA ACRILICA PENTRU PIPER

- Corp realizat din sticla acrilica transparenta (PMMA) - un substitut mai usor al sticlei, dar mai rezistent la zgarieturi si spargere.
- Mecanism de macinare (bavuri) fabricat din otel inoxidabil, manual si reglabil cu un buton rotativ.
- Capac protejat impotriva caderii cu un buton cu surub.
- Buton cu litera "P" imprimata - pentru marcarea piperului.

cod	mm	lei
469620	ø50x(H)113	29,99
469644	ø50x(H)140	29,99
469668	ø60x(H)215	40,99

### RASNITA ACRILICA PENTRU SARE

- Corpul realizat din sticla acrilica transparenta (PMMA) - un substitut mai usor al sticlei, dar mai rezistent la deteriorare
- Mecanism de macinare ceramic (bavuri) - necoroziv (adekvat pentru sare), manual si ajustabil cu un buton.
- Capac protejat impotriva caderii cu un buton cu surub.
- Buton cu litera "S" imprimata - pentru marcarea sarii.

cod	mm	lei
469637	ø50x(H)113	30,99
469651	ø50x(H)140	28,99
469675	ø60x(H)215	38,99





786413

**SET CONDIMENTE**

- Set 2 piese - sare, piper

cod	unitate de comanda	mm	lei
786413	3	ø42x(H)80	24,49



786420

**SET CONDIMENTE**

- Set 3 piese - sare, piper, suport scobitori

cod	unitate de comanda	mm	lei
786420	48	125x54x(H)90	39,99



465363

**SET CONDIMENTE**

 - 5 piese - sare, piper, ulei, otet, suport scobitori  
 - Finisare mata

cod	mm	lei
465363	130x110x(H)185	55,99



631300

631102

631201

**SOLNITA**

cod		mm	lei
631102	dispenser parmezan	ø55x(H)75	25,99
631201	solnita sare si piper	ø55x(H)75	25,99
631300	dispenser zahar pudra cu plasa	ø55x(H)75	29,99



465387

**SET SOLNITE SARE SI PIPER**

 - Recipiente din sticla  
 - Capac din otel inoxidabil, cu diferentiere continut [S si P]

cod	mm	lei
465387	ø40x(H)70	10,99



461167

461266

**RECIPIENT PENTRU SARE**

 - Corp realizat din sticla.  
 - Capac din otel inoxidabil cu deschidere de distribuire in forma de S sau P.

cod	ambalat pe	mm	lei
461266	6	ø40x(H)70	40,99



465301

**SET CONDIMENTE**

- 2 piese - sare, piper
- Finisare mata

cod	mm	lei
465301	85x55x(H)115	21,99

18/0  
stainless steel

465349

**SET CONDIMENTE**

- 2 piese - ulei, otet
- Finisare mata

cod	litri	mm	lei
465349	0.15	120x75x(H)185	39,99

18/0  
stainless steel

465332

**SET CONDIMENTE**

- 3 piese - sare, piper, mustar
- Cu lingura de mustar
- Finisare mata

cod	mm	lei
465332	100x95x(H)115	34,99

18/0  
stainless steel

465318

**SET CONDIMENTE**

- 3 piese - sare, piper, suport servetele
- Finisare mata

cod	mm	lei
465318	85x75x(H)115	25,99

18/0  
stainless steel

465325

**SET CONDIMENTE**

- 3 piese - sare, piper, suport scobitori
- Finisare mata

cod	mm	lei
465325	90x90x(H)115	29,99

18/0  
stainless steel

465356

**SET CONDIMENTE**

- 4 piese - sare, piper, ulei, otet
- Finisare mata

cod	mm	lei
465356	130x110x(H)185	49,99

18/0  
stainless steel



462904

**DOZATOR DE ULEI DE MASLINE**

- Fabricat din otel inoxidabil lucios.
- Forma conica care asigura stabilitatea.
- Dop detasabil din cu duza.

cod	litri	mm	lei
462904	0.25	ø84x(H)158	49,99



460245

**SET ULEI/OTET**

- Suport din fier placat cu crom
- 2 recipiente ulei/otet cu picuratoare din otel inoxidabil

cod	-	mm	lei
460245	2x0,237L	115x60x(H)325	43,99

**PICURATOR CU CURGERE LIBERA - 3 BUCATI**

- Pentru utilizare in baruri, pub-uri si restaurante
- Constructie rezistenta din otel inoxidabil
- Clapeta de turnare contrabalansata, care face ca duza sa se deschida si sa se inchida automat atunci cand sticla este inclinata
- Faciliteaza dozarea precisa
- Adekvat pentru sticle standard de 0,5 - 1,5 litri cu orificii cu diametru de pana la ø20 mm

18/8

stainless steel



599327



cod	nr. buc.	mm	lei
599327	3	ø30x120	29,99

18/0

stainless steel



452400

S.S.

stainless steel



452424

18/0

stainless steel



465370

**DISPENSER ZAHAR**

- Recipient din sticla
- Capac din otel inoxidabil 18/0

cod	mm	lei
452400	ø80x(H)140	17,99

**DISPENSER MIERE**

- Recipient din sticla
- Maner din otel inoxidabil

cod	mm	lei
452424	ø80x(H)115	29,99

**RECIPIENT BRANZA/ZAHAR**

- Recipient din sticla
- Include lingura din otel inoxidabil

cod	mm	lei
465370	ø130x(H)90	48,99



403747

**CLESTE PENTRU NUCI SI FRUCTE DE MARE, NEGRU MAT**

- Fabricat din otel inoxidabil foarte gros, ajuta la mentinerea continutului fierbinte.
- Gura in forma de V ofera un control suplimentar in timpul turnarii.

cod	mm	lei
403747	155x35	22,99



403754

**CLESTE PENTRU HOMAR SI CRAB**

- Perfect pentru indepartarea clestilor si carapacei homarilor sau crabilor
- Un maner larg, conturat asigura o utilizare usoara si confortabila
- Constructie solida, acoperita cu pulbere in rosie
- Clestele este conectat printr-o balama rezistenta
- Nu este potrivit pentru spalarea in masinile de spalat vase

cod	mm	lei
403754	140x62	16,99



403716

**FURCULITE HOMARI - 6 BUCATI**

cod	nr. buc.	mm	lei
403716	6	(L)205	49,99



402221

**FURCULITA MELCI - 6 BUCATI**

cod	nr. buc.	mm	lei
402221	6	(L)130	23,99



## TABLE



### TABLA PERETE

- Neagra, cu rama lemn.
- Cartile de montare incluse.

cod	mm	lei
664025	300x400	39,99
664032	400x600	54,99
664049	600x800	88,99

### TABLA STRADALA

- Neagra, cu rama lemn

cod	mm	lei
664001	500x450x(H)1850	269,99
664018	700x600x(H)1200	422,99



664100

### TABLA STRADALA

- Neagra, cu rama din otel

cod	mm	lei
664100	700x500x(H)1100	423,99



664117

### TABLA STRADALA

- Neagra, cu rama otel

cod	mm	lei
664117	500x550x(H)850	349,99

## TABLA DE MASA - 2 BUCATI

- Neagra, cu suport lemn

cod	ambalat pe	mm	lei
664087	2	148x130x(H)120	43,99



664087

## TABLA DE MASA - 2 BUCATI

- Neagra, cu suport lemn

cod	ambalat pe	mm	lei
664056	2	150x50x(H)230	29,99
664063	2	210x50x(H)320	49,99



664063

664056



664124



664131



664070

## TABLA NEAGRA CU SUPORT

- Tabla mare neagra cu rama de lemn.

- Suport de sustinere inculs.

cod	mm	lei
664124	300x400	32,99
664131	400x600	49,99

## TABLA CU SUPORT

- Neagra, cu suport din lemn

cod	mm	lei
664070	220x210x(H)360	44,99

## SCRMIERE SI DEPOZITARE GUNOI



440605



569757

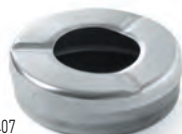

440407



### SCRMIERA CU SPATIU COLECTARE SCRUM

cod	mm	lei
440605	ø140x(H)40	21,99

### SCRMIERA - Melamina neagra

cod	mm	lei
569757	ø146x(H)60	34,99

### SCRMIERA

cod	ambalat pe	mm	lei
440407	1	ø90x(H)28	15,99
440490	3	ø90x(H)28	29,99



440803



440001



440872



### SCRMIERA

cod	mm	lei
440803	ø80x(H)30	17,99
440858	ø100x(H)30	18,99
440902	ø120x(H)30	20,99

### SCRMIERA CU SPATIU COLECTARE SCRUM

cod	mm	lei
440001	ø140x(H)30	10,99
440100	ø160x(H)30	14,99

### SCRMIERA

cod	mm	lei
440872	ø80x(H)30	12,99
440865	ø100x(H)30	15,99



440230



### SCRMIERA NEAGRA

- Fabricata din otel inoxidabil, exterior cu un strat negru mat.
- Inel detasabil

cod	mm	lei
440230	ø105x(H)58	32,99



440209



### SCRMIERA CU BUTON

cod	mm	lei
440209	ø90x(H)45	24,99



440506



### SCRMIERA.

- Capac cu balama.
- Pentru golirea in siguranta a scrumierelor.
- Auto-stingere.

cod	mm	lei
440506	202x170x(H)91	129,99



440216

### SCRUMIERA CU MONTARE PE PERETE

- Design foarte robust, usor de montat pe pereti si stalpi
- Usor de golit datorita bazei care poate fi accesata cu o cheie

cod	mm	lei
440216	ø75x(H)460	329,99



440223

### SCRUMIERA TIP STALP

- Design foarte robust, poate fi montat pe podea cu prindere fixa sau fara prindere.
- Usor de golit, partea superioara poate fi deblocata cu o cheie.
- Baza este de ø170 mm, iar stalpul este de ø75 mm

cod	mm	lei
440223	ø170x(H)920	499,99



440117



**NOU**

### SCRUMIERA DE STICLA CU PALNIE DE OTEL

- 2 elemente separate:
  - corp realizat din sticla, rezistent la temperaturi ridicate,
  - palnie fabricata din otel inoxidabil.
- Cu 3 fante pentru tigarete.
- Palnia directioneaza cenusa in scrumiera si serveste drept capac:
  - atunci cand este utilizata in interior
  - reduce mirosurile de fum, atunci cand este utilizata in aer liber
  - antivânt

cod	mm	lei
440117	ø98x(H)99	28,99



691380

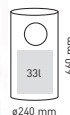

691397



### COS DE GUNOI CU SCRUMIERA

- Constructie din otel inoxidabil
- Suprafata slefuita
- Scrumiera detasabila, cu gratar, plasata deasupra cosului pentru o usoara curatare si golire a cosului
- Deschidere cos 135 mm
- Baza din cauciuc anti-alunecare pentru a asigura stabilitate si protectia pardoselii impotriva zgarieturilor

cod	litri	mm	lei
691380	15	ø200x(H)700	197,99
691397	33	ø240x(H)660	387,99





design by  
Robert Bronwasser

# UNIQ

## Buffet reinvented

- Design modern conceput de Robert Bronwasser
- Carcasa din polipropilena rezistenta la temperaturi inalte
- Element de incalzire din otel inoxidabil AISI 304
- Capac transparent fabricat din sticla temperata
- Echipat cu un maner izolat termic

Prodotus premiat



reddot winner 2024

NOU



Vezi filmul



- Capac conceput pentru a directiona condensul in container
- Capac cu balama din aluminiu si fanta pentru polonic

- Display digital, usor de citit
- Suport pentru etichete
- Picioare antialunecare

### Supiera HENDI UNIQ

- Container pentru supa detasabil
- Otel inoxidabil AISI 304, usor de curatat
- Constructie din 2 parti
- Capacul reduce pierderile de caldura



### Chafing Dish HENDI UNIQ

- Senzor pentru nivelul de apa
- Containerul pentru apa gradat indica nivelul optim de apa



COMBUSTIBIL, BUFET





design by  
Robert Bronwasser



### SUPIERA HENDI UNIQ

cod	culoare	V	W	mm	lei
860526	Negru	230	500	ø365x(H)325	749,00
860533	Alb	230	500	ø365x(H)325	749,00
860540	Verde	230	500	ø365x(H)325	749,00



### CHAFING DISH HENDI UNIQ

cod	culoare	V	W	mm	lei
470411	Negru	230	700	607x402x(H)245	899,00
470428	Alb	230	700	607x402x(H)245	899,00
470435	Verde	230	700	607x402x(H)245	899,00



## SUPIERA ELECTRICA



Capaca cu maner izolat si fanta pentru polonic

Capac detasabil din policarbonat dur transparent



860502

Panou tactil digital cu afisaj care ardeaza temperatura setata cu temperatura actuala a supei

Ajustat de la 65° la 95°C in trepte de 1°



Protectie la supraincalzire - cu alarma pentru nivel scazut de apa

### SUPIERA

- Izolarea termica reduce consumul de energie si mentine partea exterioara rece
- Datorita acestor avantaje se poate reduce consumul de energie cu pana la 30%
- Capac detasabil din policarbonat dur transparent
- Vas apa din aluminiu pentru transfer eficient de caldura
- Vas pentru supa din otel inoxidabil 18/8
- Carcasa polipropilena
- Inelul ajuta la scoaterea in siguranta si usor a oalei pentru reumplere cu apa
- Suport pentru eticheta
- Potrivit pentru bufet

cod	litri	V	W	mm	lei
860502	8	230	450	ø370x(H)316	<b>359,99</b>

COMBUSTIBIL, BUFET



860083

**MODEL NOU**



### SUPIERA

- Recipient pentru supa si capac din otel inoxidabil AISI 201.
- Recipient de apa realizat din otel inoxidabil AISI 201.
- Carcasa confectionata din metal cu acoperire cu pulbere neagra.
- Capac cu un maner care nu se incalzeste si suport pentru polonic.
- Interval de temperatura: 30-85°C.
- Protectie la supraincalzire la 105°C.
- Reglarea temperaturii cu un cadran - 5 niveluri.
- Capacitate: 8 l.

cod	litri	V	W	mm	lei
860083	8	230	400	ø330x(H)363	<b>373,99</b>



204825



### CHAFING DISH ELECTRIC TELLANO

- Gastronorm 1/1
- Tava pentru apa fabricata din polipropilena rezistenta la temperaturi mari
- Setare temperatura pana la 85°C
- Comutator ON/OFF, indicator lumina
- Include vascheta GN 1/1 de 65 mm adancime

cod	litri	V	W	mm	lei
204825	9	230	900	573x347x(H)286	449,99



204900

### CHAFING DISH ELECTRIC POLLINA

- GN 1/1
- Setare temperatura pana la 85°C
- Cu suport capac
- Buton oprire/pornire, indicator lumina
- Include vas GN 1/1 cu 65 mm adancime
- Potrivit pentru vaschete de pana la 100 mm adancime



cod	litri	V	W	mm	lei
204900	9	230	850	610x450x(H)278	649,99



204832

### CHAFING DISH ELECTRIC TESINO

- Tava pentru apa este din polipropilena rezistenta la temperaturi mari.
- Setari continue pana la 85 °C.
- Comutator oprire/pornire, indicator lumina.
- Include vas alimente de 6.8 lt.



cod	litri	V	W	mm	lei
204832	6.8	230	500	ø405x(H)240	459,99





475904



475201



470619



472507

18/0  
stainless steel**CHAFING DISH GASTRONORM 1/1**

- Model Economic
- Capac lucios si suport capac
- Include suporturi combustibil chafing dish si vas din otel inoxidabil cu 65 mm adancime
- Potrivit pentru vase cu adancime max. 65 mm

cod	ambalat pe	litri	mm	lei
472613	2	9	600x358x(H)295	<b>449,99</b>
475904	1	9	600x358x(H)295	<b>249,99</b>

18/0  
stainless steel**CHAFING DISH GASTRONORM 1/2**

- Model Economic
- Capac lucios si suport capac
- Include suport combustibil chafing dish si vas din otel inoxidabil cu 65 mm adancime
- Potrivit pentru vase cu adancimea maxima 65 mm

cod	litri	mm	lei
475201	4.5	385x295x(H)310	<b>254,99</b>

S.S.  
stainless steel18/0  
stainless steel**CHAFING DISH - ROTUND**

- Capac din sticla
- Include suport pentru combustibil chafing dish si vas din otel inoxidabil

cod	litri	mm	lei
470619	3.5	ø390x(H)270	<b>243,99</b>

S.S.  
stainless steel**CHAFING DISH SUPIERA**

- Model Economic
- Include suport pentru combustibil chafing dish si vas supa din otel inoxidabil cu capac

cod	litri	mm	lei
472507	8	ø370x(H)325	<b>281,99</b>



**S.S.**  
stainless steel

**18/0**  
stainless steel

### CHAFING DISH GASTRONORM 1/1

- Model Fiara
- Rama stocabila cu capac lucios si suport capac
- Include 2 suporturi combustibil chafing dish si vascheta din otel inoxidabil de 65 mm adancime
- Potrivit pentru vaschete Gastronorm de pana la 100 mm adancime

cod	litri	mm	lei
471005	9	585x385x(H)315	279,99



471005



470190

**S.S.**  
stainless steel

### TAVA GN 1/1 CU 2 COMPARTIMENTE

- Aceasta tava GN are doua compartimente de cate 3,75 litri fiecare.

cod	litri	mm	lei
470190	7.5	530x325x(H)65	81,99



471050



**S.S.**  
stainless steel

### ACCESORIU CONVERSIE PENTRU 2 RECIPIENTE

- Se potriveste perfect in adaptorul pentru recipiente 470930.
- Adecvat si pentru: Termosistem [201107, 201206].
- Fabricat din otel inoxidabil.
- Capac prevazut cu maner confortabil.

cod		mm	lei
470930	adapter	530x325x(H)30	94,99
470909	caserola cu cosuri 4,2 l	ø220x(H)190	99,99

### SET CHAFING DISH

- Contine :
  - Chafing dish Fiara 471005
  - 2 vaschete suplimentare GN 1/2 - 65 mm
  - 3 vaschete suplimentare GN 1/3 - 65 mm

**S.S.**  
stainless steel

**18/0**  
stainless steel

cod	mm	lei
471050	585x385x(H)315	399,99

# Fine Dine

PROFESSIONAL TABLETOP & BAR

## ARTA SERVIRII RAFINATE



Descoperiți articolele unice de vesela Fine Dine, care vor spori eleganța restaurantului dumneavoastră. Fabricate din materiale de cea mai bună calitate, acestea vor asigura o experiență de neuitat pentru oaspeții dumneavoastră. Creșteți standardele restaurantului dvs. și creați o atmosferă unică cu Fine Dine.



## INCALZITOR VASE CU 2 SUPORTURI COMBUSTIBIL

- Cadru si manere din otel inoxidabil
- Plita din aluminiu
- Rezistent la zgariereturi
- Include 2 suporturi de combustibil

cod	mm	lei
463000	330x180x(H)65	174,99

## INCALZITOR VASE CU 3 SUPORTURI COMBUSTIBIL

- Cadru si manere din otel inoxidabil
- Plita din aluminiu
- Rezistent la zgariereturi
- Include 3 suporturi de combustibil

cod	mm	lei
463109	450x180x(H)65	199,99

## SUPORT COMBUSTIBIL

code	mm	lei
464809	ø46x(H)20	6,99



## ELEMENT INCALZIRE CHAFING DISH

- Pentru folosirea ca alternativa la chafing dish-ul conventional
- Numai pentru folosirea la chafing dish cu baza plata
- Potrivit pentru chafing dish non-electric
- Potrivit pentru chafing dish HENDI coduri 470008, 475201, 470206 si 471005

cod	V	W	mm	lei
809600	230	500	ø130x(H)125	199,99

## ELEMENT INCALZIRE CHAFING DISH, PENTRU TAVA DE APA

- Incalzitoul are o putere de iesire unica si stabila (nu are o functie de reglare a temperaturii).
- Nu este destinat gatitului, ci doar mentinerii la cald.
- Se potriveste perfect cu tava de apa pentru vase HENDI Chafing (cod: 809716).
- Adecvat si pentru tava GN 1/1 (cod: 470206) si orice alte tavi GN 1/1 daca acestea sunt prevazute cu gauri pentru suruburi.

cod	V	W	mm	lei
809709	230	380	300x200x(H)40	289,99



463000



463109



464809



198124

## BRICHETA - 2 BUCATI

- Reincarabila
- Bricheta se distribuie neincarcata

cod	ambalat pe	mm	lei
198124	2	(L)230	36,99



809600



809716



## CHAFING DISH PROFI LINE

- Ideal pentru bufet si catering. Folosind materiale de inalta calitate si un finisaj estetic, acesta ofera un aspect rafinat preparatelor dvs.
- Vasele si accesoriile sunt realizate in intregime din otel inoxidabil rezistent.



Vezi filmul

COMBUSTIBIL, BUFET





470251

### CHAFING DISH GN 1/1 FINISAJ SATINAT

- Capacul este prevazut cu un sistem de blocare, ramane in pozitia in care este lasat. Capacul poate fi indepartat pentru a usura curatarea.
- Livrat cu recipient pentru apa detasabil, GN 1/1 adancime de alimentare cu atunecare si cu 2 suporturi combustibil.

cod	litri	mm	lei
470251	9	570x430x(H)290	499,99



470275

### CHAFING DISH GN 2/3 FINISAJ SATINAT

- Capacul este prevazut cu o un sistem de blocare, ramane in pozitia in care este lasat. Capacul poate fi indepartat pentru a usura curatarea.
- Livrat cu recipient pentru apa detasabil, GN 2/3 cu adancime de 65 mm si suport pentru combustibil

cod	litri	mm	lei
470275	6	395x430x(H)290	419,99



470268

### CHAFING DISH GN 1/2 FINISAJ SATINAT

- Capacul este prevazut cu sistem de blocare, iar acesta ramane in pozitia in care este lasat. Capacul poate fi indepartat pentru a usura curatarea.
- Livrat cu recipient pentru apa detasabil, GN 1/2 adancime de 65 mm pentru adaparea alimentelor si suport pentru combustibil.

cod	litri	mm	lei
470268	4	365x370x(H)280	374,99



Vezi filmul



470282

### CHAFING DISH ROTUND FINISAJ SATINAT

- Capacul este prevazut cu sistem de blocare, iar acesta ramane in pozitia in care este lasat. Capacul poate fi indepartat pentru a usura curatarea.
- Livrat cu un recipient rotund pentru apa, o tava cu adancime de 65 mm si un suport pentru combustibil.

cod	litri	mm	lei
470282	6	465x420x(H)320	439,99



## CHAFING DISH PROFI LINE

- Ideal pentru bufet si catering. Folosind materiale de inalta calitate si un finisaj estetic, aceasta ofera un aspect rafinat preparatelor dvs.
- Vasele si accesoriile sunt realizate in intregime din otel inoxidabil durabil.



470213

### CHAFING DISH GN 1/1 FINISAJ TIP OGLINDA

- Capacul este prevazut cu sistem de blocare, iar acesta ramane in pozitia in care este lasat. Capacul poate fi indepartat pentru a usura curatarea.
- Livrat cu recipient de apa detasabil, tava GN 1/1 cu adancime de 65 mm si cu 2 suporturi pentru combustibil.

cod	litri	mm	lei
470213	9	570x405x(H)320	599,99



470237

### CHAFING DISH GN 2/3 FINISAJ TIP OGLINDA

- Capacul este prevazut cu sistem de franare, iar acesta ramane in pozitia in care este lasat. Capacul poate fi indepartat pentru a usura curatarea.
- Livrat cu recipient de apa detasabil, tava GN 2/3 cu adancime de 65 mm si suport pentru combustibil.

cod	litri	mm	lei
470237	6	395x405x(H)320	519,99



470220

### CHAFING DISH GN 1/2 FINISAJ TIP OGLINDA

- Capacul este prevazut cu sistem de blocare, iar acesta ramane in pozitia in care este lasat. Capacul poate fi indepartat pentru a usura curatarea.
- Livrat cu recipient de apa detasabil, GN 1/2 adancime de 65 mm si suport pentru alimentarea cu combustibil.

cod	litri	mm	lei
470220	4	365x345x(H)345	459,99



Vezi filmul

470244



### CHAFING DISH PENTRU SUPA CU FINISAJ TIP OGLINDA

- Containerul rotund de supa este plasat intr-o tava mare de apa care ofera o cantitate mare de caldura pentru a mentine supa fierbinte.
- Recipientul pentru supa prevazut cu doua manere.
- Capacul are o fanta pentru lingura.
- Livrat cu tava de apa detasabila, rezervor rotund pentru supa si suport pentru combustibil.

cod	litri	mm	lei
470244	10	ø420x(H)380	519,99

18/0  
stainless steel

### CHAFING DISH ROLLTOP GASTRONORM 1/1

- Model Rental-Top
- Baza solida cu capac rabatabil lucios din otel inoxidabil 18/0
- Include 2 suporturi pentru combustibil chafing dish si tava GN din otel inoxidabil de 65 mm adancime
- Baza prevazuta cu suruburi de fixare pentru element electric de incalzire, cod produs 809709
- Potrivit pentru tavi GN cu pana la 100 mm adancime

cod	litri	mm	lei
470206	9	590x340x(H)400	592,99



470206

S.S.  
stainless steel

### CHAFING DISH ROLLTOP GASTRONORM 1/1

- Chafing dish elegant pentru bufet
- Sistem de deschidere fara zgomot
- Capac retractabil pana la 180°
- Instalare optionala pentru sistem incalzire electric
- Otel inoxidabil lustruit
- Rama din otel cu grosime de 2,3 mm, grosime capac 1.2 mm
- Setul include 2 suporturi pentru combustibil si un vas GN 1/1 - 65 mm

cod	litri	mm	lei
470305	9	660x490x(H)460	718,99



470305

S.S.  
stainless steel

### CHAFING DISH ROLLTOP - ROTUND

- Chafing dish elegant pentru bufet
- Sistem de deschidere fara zgomot
- Capac rolltop retractabil la 180°
- Setul include un suport combustibil si vas alimente - diametru 390 mm, inaltime 60 mm
- Otel inoxidabil lustruit
- Rama otel 2,3 mm, capac grosime 1,2 mm

cod	litri	mm	lei
470312	5.6	510x540x(H)480	529,99



470312





**COMBUSTIBIL CHAFING DISH - CONSERVA**

- 200 g
- Timp de ardere: ~ 3 ore
- Se vinde doar la set

cod	ambalat pe	lei
194357	6	34,99
194539	24	131,99
194546	48	239,99

## COMBUSTIBIL LICHID CU FITIL

- Recipient HENDI cu fitil, contine 100% dietilen glicol
- Arde complet
- Fara funingine sau miros
- Fitil special ce ofera timp de ardere si temperatura adecvate
- Recipientul nu se incalzeste, nu este necesar suportul
- Temperatura flacarii si inaltimea acesteia sunt constante pe toata perioada arderii
- Set 24 buc.
- Datorita capacului special aveti posibilitatea de a folosi recipientul de mai multe ori, acesta putand fi transportat si depozitat in siguranta



Fitil special ce ofera timp de ardere si temperatura adecvate  
Utilizare repetata a aceluasi recipient

Cutia nu se incalzeste,  
nu este necesar suportul

Datorita capacului special aveti posibilitatea de a folosi recipientul de mai multe ori, acesta putand fi transportat si depozitat in siguranta



4 ore



6 ore

cod	timp de ardere	ambalat pe	greutate (kg)	lei
193693	4 ore	24	145	159,99
193686	6 ore	24	200	171,99





190029

### COMBUSTIBIL CHAFING DISH - SET 2 BUCATI

- Destinat radiatoarelor gastronomice.
- Etanol (bio) gros, contaminat.
- Un set de 2 galeti, fiecare contine 4 kg de pasta.
- Vandut numai sub forma de kit.
- Greutate neta (2 buc.): 8 kg.

cod	lei
190029	143,99



195505

### COMBUSTIBIL CHAFING DISH

- Bidon 5 litri

cod	unitate de comanda	lei
195505	4	79,99



195109

### COMBUSTIBIL CHAFING DISH

- Sticla de 1 litru

cod	unitate de comanda	lei
195109	12	15,99



470527



### SUPORT COMBUSTIBIL CHAFING DISH - 2 BUCATI

cod	ambalat pe	mm	lei
470527	2	ø90x(H)60	33,99



195604

### DISPENSER COMBUSTIBIL

- Potrivit pentru 195505

cod	mm	lei
195604	(L)280	101,99

# Pasta sau combustibil cu fitil?



Vezi filmul



## PASTA

## COMBUSTIBIL LICHID

Pasta pe baza de etanol de calitate 96% Pasta HENDI contine 70% etanol	Lichid - Dietilen glicol
Arderea are loc in interiorul canistrei	Arderea se produce in afara canistrei, prin intermediul fitilului Inaltimea fitilului poate fi ajustata, controland astfel intensitatea si inaltimea flacarii
Intensitatea flacarii este redusa in timpul arderii	Ardere intensa si uniforma
In timpul arderii - eficienta incalzirii este scazuta	Ardere eficienta pana la terminarea combustibilului
Recipientul se incalzeste	Recipientul nu se incalzeste <b>Nu este nevoie de suport pentru canistra</b>
Recipient reutilizabil	Posibilitatea de a inchide recipientul cu un capac
Caistra reutilizabila	Canistra nu se poate reutiliza dupa consumarea combustibilului
Timp de ardere 200g - 3h	Timp de ardere 200g - 6h

Nu emite gaze toxice  
Nu innegreste vasul incalzit

Pentru spatii inchise  
Pentru evenimente in aer liber





### POLONIC SUPA

cod	litri	mm	lei
529089	0.05	270x69	<b>33,99</b>
529096	0.09	308x85	<b>44,99</b>

### LINGURA SERVIRE

cod	mm	lei
529058	305x60	<b>37,99</b>
529065	321x71	<b>32,99</b>

### LINGURA SERVIRE PERFORATA

cod	mm	lei
529072	321x71	<b>32,99</b>



### LINGURA PENTRU APERITIV CU MELAMINA

cod	culoare	mm	lei
566534	Alb	130x45	<b>12,99</b>
566596	Negru	135x45	<b>12,99</b>



## POLONICE SI LINGURI SERVIRE CHAFING DISH

- Cu maner din polipropilena



529003

529010

529300

529201

529041

529102

529409

### POLONIC SUPA

cod	litri	mm	lei
529003	0.09	335x90	<b>30,99</b>
529010	0.11	300x80	<b>29,99</b>

### SPUMIERA - ROTUNDA

cod	mm	lei
529041	370x105	<b>29,99</b>

### SPATULA CU FANTE

cod	mm	lei
529409	355x80	<b>29,99</b>

### SPUMIERA

cod	mm	lei
529201	345x75	<b>29,99</b>

### LINGURA SERVIRE

cod	mm	lei
529300	350x75	<b>27,99</b>

### FURCULITA CARNE

cod	mm	lei
529102	345x32	<b>27,99</b>



722107



### SUPPORT LINGURA

cod	mm	lei
722107	115x270x(H)45	<b>29,99</b>



## USTENSILE SERVIRE REZISTENTE LA CALDURA



### TACAMURI SALATA

cod		mm	lei
563908	Lingura pentru salata	(L)305	17,19
564004	Furculita pentru salata	(L)305	18,99

### LINGURA SOS

cod	culoare	litri	mm	lei
563502	Alb	0.07	235x75	16,99
563557	Negru	0.07	235x75	16,99
563700	Alb	0.14	300x93	18,99
563755	Negru	0.14	300x93	18,99



### LINGURA SALATA

cod	culoare	mm	lei
564158	Negru	235x55	8,99
564202	Transparent	235x55	8,99
564103	Alb	235x55	8,99

### POLONIC SOS

cod	culoare	litri	mm	lei
563649	Negru	0.03	180x70	8,99
563632	Ivorie	0.03	180x70	8,99

### LINGURA SALATA

cod	culoare	mm	lei
564400	Alb	335x70	13,99
564455	Negru	335x70	13,99



## CLESTI SERVIRE

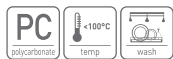

### CLESTE SERVIRE

cod	culoare	mm	lei
657621	Transparent	(L)230	12,99
657607	Negru	(L)230	12,99



### CLESTE PENTRU PRAJITURI - Cleste decorativ.



cod	mm	lei
171622	(L)280	15,99
171608	(L)220	17,99



### CLESTE PRAJITURI - Cleste decorativ

cod	mm	lei
171615	(L)220	18,99



### CLESTE PATISERIE

cod	mm	lei
523018	(L)215	16,99



### CLESTE SALATA

cod	mm	lei
523315	(L)212	15,99



### CLESTE SPAGHETTI

cod	mm	lei
523216	(L)200	15,99



## ARTICOLE PREZENTARE BUFET



424186

### DISPLAY ROLLTOP RACIRE - GASTRONORM 1/1

- Racire cu pachet de gheata, pentru temperaturi sub 0°C, inclus in pachet
- Tava servire din otel inoxidabil GN 1/1 inclusa
- Capac rolltop transparent din policarbonat
- Carcasa ABS

cod	-	mm	lei
424186	set	555x357x(H)175	529,99
424193	element de racire pentru tava de racire 424186	528x324x(H)30	104,99



424193



424155

### TAVA DE PREZENTARE CU RACIRE



- Set de 5 piese:
  - Baza realizata din polistiren.
  - Tava din otel inoxidabil, cu o margine profilata.
  - Capac transparent fabricat din plastic PP.
  - 2 elemente de racire.
- NOTA: Inainte de congelare, umpleti elementul de racire cu apa pana la 90% din volumul sau.
- Tava se comercializeaza, de asemenea, separat (cod: 871829).

cod	mm	lei
424155	430x290x(H)150	159,99

530





871805



### DISPLAY ROLL-TOP

Set de 5 piese:

- Baza fabricata din ABS.
- Tava din otel inoxidabil, cu o margine profilata.
- Capac transparent tip rola realizat din plastic SAN, cu deschidere pana la 90°.
- 2 elemente de racire.
- NOTA: Inainte de congelare, umpleti elementul de racire cu apa pana la 90% din volumul sau.

cod	mm	lei
871805	440x320x(H)205	279,99



871812



### DISPLAY ROLL-TOP DUBLU

Set de 9 piese:

- Baza pe 2 niveluri fabricata din plastic ABS.
- 2 tavi din otel inoxidabil, cu o margine profilata.
- 2 capace transparente cu rola din plastic SAN, cu deschidere pana la 90°.
- 4 elemente de racire.
- NOTA: Inainte de congelare, umpleti elementul de racire cu apa pana la 90% din volumul sau.

cod	mm	lei
871812	440x320x(H)440	499,99

### DISPLAY ROLL TOP, CU DUBLA UTILIZARE

- Pentru a servire branzeturi, mezeluri, paine, prajituri sau gustari
- Fabricat din polipropilena cu insertie din otel inoxidabil
- Capac transparent pentru rola din polistiren
- Expunere perfecta
- Acces convenabil la alimentele servite din ambele parti ale tavii de prezentare.
- Doua functii: prezentare preparate calde sau reci
- Elemente de racire/incalzire amplasate sub insertia din otel inoxidabil a tavii pentru a mentine temperatura in compartiment, pastrand alimentele proaspete si aspectuase pentru mai mult timp.
- Usor de curatat.
- Asamblare/dezasamblare rapida.
- Culoare tava: carcasa neagra cu insertie din otel inoxidabil.
- Proiectat si produs 100% in Italia.
- Setul include 2 insertii de gel pentru racirea sau incalzirea alimentelor plasate in carcasa de afisaj.
- Nu contine bisfenol A.
- Poate fi spalata in masina de spalat vase.

cod	mm	lei
871775	465x315x(H)195	280,99



871775





871706

### DISPLAY ROLLTOP

- Capac transparent cu rola, fabricat din polistiren.
- Acces convenabil la alimentele servite din ambele parti ale tavii de prezentare.
- Usor de curatat.
- Poate fi spalata in masina de spalat vase.

cod	mm	lei
871706	465x310x(H)190	178,99



871713

### DISPLAY ROLLTOP - DUBLA

- Capac transparent cu rola, fabricat din polistiren.
- Acces convenabil la alimentele servite din ambele parti ale tavii de prezentare.
- Usor de curatat.
- Poate fi spalata in masina de spalat vase.

cod	mm	lei
871768	380x260x(H)355	155,99
871713	465x310x(H)410	316,99



424001



### CAPAC ROLL TOP

- Tava din otel inoxidabil, cu o margine profilata.
- Capac realizat din plastic SAN, cu un buton cromat, deschis unilateral pana la 90° (inclus in set).
- Tava poate fi spalata in masina de spalat vase.
- Capacul se comercializeaza si separat (cod: 427514).

cod	mm	lei
424001	ø380x(H)240	239,99



980101



### TAVA ROTUNDA CU CAPAC

- Tava din otel inoxidabil, cu manere.
- Capac realizat din plastic SAN, cu maner extrudat.
- Ambele elemente ale setului pot fi spalate in masina de spalat vase.

cod	mm	lei
980101	ø300x(H)110	49,99



### TAVA ROTUNDA CU CAPAC PENTRU RULOU

- Tava din policarbonat negru.
- Capac transparent din policarbonat care se potriveste in tava protejeaza perfect produsele impotriva uscarii.
- Materialul utilizat nu influenteaza gustul sau mirosul produselor depozitate.
- Rezistenta la temperatura de la -40 °C pana la +99 °C
- Greutate: 0,65 kg.
- Dimensiuni interioare: ø350x(H)180 mm.
- Poate fi spalata in masina de spalat vase.
- Reciclabil.

cod	mm	lei
203552	øx(H)215	119,99

### TAVA ROTUNDA CU CAPAC

- Fabricat din policarbonat de culoare neagra.
- Capac transparent din policarbonat care se potriveste in tava protejeaza perfect produsele impotriva uscarii.
- Maner negru confortabil.
- Materialul utilizat nu influenteaza gustul sau mirosul produselor depozitate.
- Rezistenta la temperatura de la -40 °C pana la +99 °C.
- Greutate: 0,40 kg.
- Poate fi spalata in masina de spalat vase.
- Reciclabil.

cod	mm	lei
203569	ø300x(H)165	58,99
203576	ø350x(H)165	99,99



### TAVA DREPTUNGIULARA CU CAPAC

- Fabricat din policarbonat de culoare neagra.
- Capac transparent din policarbonat care se potriveste in tava protejeaza perfect produsele impotriva uscarii.
- Maner negru confortabil.
- Materialul utilizat nu influenteaza gustul sau mirosul produselor depozitate.
- Rezistenta la temperatura de la -40 °C pana la +99 °C.
- Greutate: 0,93 kg.
- Poate fi spalata in masina de spalat vase.
- Reciclabil.

cod	mm	lei
203583	335x275x(H)165	89,99
203590	535x335x(H)165	156,99





**CAPAC ROLLTOP**  
- Policarbonat transparent



cod	mm	lei
427507	540x330x(H)180	159,99



**CAPAC PREZENTARE**



cod	mm	lei
866009	545x335x(H)95	179,99



**CAPAC ROLLTOP GN 2/3**  
- Policarbonat transparent



cod	mm	lei
427538	Capac rolltop 365x335x(H)175	139,99



**CAPAC PREZENTARE**



cod	mm	lei
427415	530x325x(H)76	94,99



### SUPORT ROTATIV PENTRU PRAJITURI

- Fabricat din otel inoxidabil.
- Rotatie a bazei fara efort in ambele directii, facilitand decorarea si taierea prajiturilor.
- Pe un picior stabil cu baza anti-alunecare.
- Capacul se comercializeaza si separat (cod: 523834).



cod	mm	lei
523827	ø300x(H)90	269,99



523834

523827



### TAVA DIN BAMBUS CU CAPAC

- Tava din bambus cu structura uniforma: tratata cu ulei, rezistenta la umezeala, rezistenta la deformare, nu absorbe mirosurile.
- Capac realizat din polistiren.
- Montat cu picioare anti-alunecare.
- Margine profilata care mentine capacul in pozitie.
- Tava si capacul nu pot fi spalate in masina de spalat vase.

cod	mm	lei
523841	320x160x(H)110	63,99



523841



### PALETA SERVIRE TORT

- Maner polipropilena

cod	mm	lei
523902	260x55	23,99



523902

523957



### PALETA SERVIRE TORT

- Cu maner negru din polipropilena
- Cu parti laterale taioase

cod	mm	lei
523957	300x75	39,99



## DISPENSERE SI RECIPIENTE SUC



Vezi filmul

425299



425411



### DISPENSER SUC

- Racirea cilindrului cu cuburi gheata
- Tava de picurare usor de curatat
- Container suc din policarbonat transparent
- Cu robinet anti-picurare

cod	litri	mm	lei
425299	8	265x350x(H)580	<b>359,99</b>
425411	16	560x350x(H)580	<b>719,99</b>



COMBUSTIBIL, BUFET



425428



425435



### DISPENSER SUC

- Racirea cilindrului cu cuburi gheata
- Tava de picurare usor de curatat
- Container suc din policarbonat transparent
- Cu robinet anti-picurare

cod	litri	mm	lei
425428	3	215x315x(H)490	<b>329,99</b>
425435	6	415x315x(H)490	<b>629,99</b>



### DISPENSER SUC

- Racirea cilindrului cu cuburi gheata
- Container suc din policarbonat transparent
- Cu robinet anti-picurare

cod	litri	mm	lei
425190	5	280x220x(H)510	422,99



425190



### DISPENSER LAPTE - 10,5 LT

- Carcasa din otel inoxidabil
- Racirea cilindrului cu cuburi gheata
- Container detasabil cu robinet anti-picurare
- Placa de baza fixa cu tava de picurare

cod	litri	mm	lei
425343	10.5	260x360x(H)536	1069,00



425343



### MULTIDISPENSER

- Potrivit doar pentru alimente uscate
- Suport din otel inoxidabil
- Containerul din policarbonat
- Capac inchis ermetic pentru pastrarea indelungata a prospectii produselor
- Igienic, dozarea controlata previne varsarea
- Montabil pe perete sau pe masa

cod	litri	mm	lei
557402	4	184x240x(H)600	374,99



557402







425138

**CARAFĂ SUC**

- Model simplu din plastic transparent rezistent la zgarieturi (cu capac inclus)

cod	litri	mm	lei
425138	2	ø120x(H)250	<b>79,99</b>



425107

**CARAFĂ SUC CU TUB GHEATĂ**

- Plastic transparent SAN rezistent la zgarieturi

- Echipat cu tub gheață pentru racire

cod	litri	mm	lei
425107	2.2	ø150x(H)260	<b>99,99</b>
425121	3	ø170x(H)285	<b>119,99</b>



567906

**CARAFĂ**

- Rezistentă mare

cod	litri	mm	lei
567906	1.8	ø125x(H)210	<b>34,99</b>



425763

**CARAFĂ**

- Cu capac

cod	litri	mm	lei
425763	1	ø92x(H)245	<b>39,99</b>

**STANDURI SERVIRE**

425466

425473



480519



429914

**SUPORT SERVIRE PENTRU FĂRFURII**

cod	farfurii cu ø	mm	lei
425466	max. 170 mm	185x175x(H)260	<b>64,99</b>
425473	max. 275 mm	290x290x(H)440	<b>94,99</b>

**ETAJERA SERVIRE FRUCTE DE MARE**

- Cu 2 tavi de servire, ø300/400 mm.

cod	mm	lei
480519	ø400x(H)200	<b>109,99</b>
480502	Doar standul ø250x(H)190	<b>36,99</b>

**ETAJERA**

- Cu 3 tavi, ø166/220/268 mm.

cod	mm	lei
429914	ø268x(H)320	<b>134,99</b>



## MELAMINA

- Igiena si rezistenta la soc
- Greutate redusa



### PLATOU RECTANGULAR

cod	mm	lei
561508	360x205x(H)38	<b>68,99</b>
561515	495x270x(H)56	<b>124,99</b>



561607

### TAVA GN 1/1

cod	mm	lei
561607	530x325x(H)20	<b>94,99</b>



566008

566015

### TAVI GASTRONORM

- Fabricat din melamina

cod	mm	lei
566046	265x162x(H)20	<b>29,99</b>
566022	325x177x(H)20	<b>36,99</b>
566015	325x265x(H)20	<b>43,99</b>
566053	530x163x(H)20	<b>59,99</b>
566930	354x325x(H)20	<b>71,99</b>
566008	530x325x(H)20	<b>81,99</b>



566206



561560

### BOL PATRAT

cod	culoare	mm	lei
566206	Negru	190x190x(H)90	<b>132,99</b>
561560	Alb	130x130x(H)65	<b>21,99</b>
561577	Alb	190x190x(H)100	<b>49,99</b>
561584	Alb	270x270x(H)105	<b>93,99</b>





561775

### PLATOU ROTUND PENTRU TORT

- Fabricat din melamina.
- Pe un picior cu o suprafata extinsa si stabila.
- Poate fi spalat in masina de spalat vase.

cod	mm	lei
566572	ø310x(H)80	149,99
561775	ø310x(H)160	179,99



566527

### STAND PATRAT PENTRU PRAJITURI

- Fabricat din melamina.
- Pe un picior cu o suprafata extinsa stabila.
- Poate fi spalat in masina de spalat vase.

cod	mm	lei
566589	310x310x(H)80	183,99
566527	310x310x(H)160	223,99



561966



561973



561980

### STAND PREZENTARE ANTI-ALUNECARE

- Cadru din otel acoperit cu PVC
- Poate sustine o varietate de tavi de prezentare si boluri

cod	mm	lei
561973	265x230x(H)200	54,99
561966	260x230x(H)100	39,99

### STAND PREZENTARE ANTI-ALUNECARE

- Cadru din otel acoperit cu PVC
- Poate sustine o varietate de tavi de prezentare si boluri

code	mm	lei
561980	ø200x(H)100	49,99



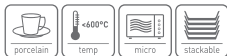

783009



783016



783023



785010



428245

## PORTELAN

- Portelan special, cel mai dur tip disponibil in piata
- Rezistent la soc termic, poate rezista la schimbari de temperatura
- Rezistenta la uzura si la impact desi este relativ usor
- Portelan alb lucios

### TAVA GASTRONORM GN 1/1

cod	-	mm	lei
783009	GN 1/1	530x325x(H)65	<b>299,99</b>

### TAVA GASTRONORM GN 1/2

cod	-	mm	lei
783016	GN 1/2	325x265x(H)65	<b>109,99</b>

### TAVA GASTRONORM GN 1/3

cod	-	mm	lei
783023	GN 1/3	325x176x(H)65	<b>71,99</b>

## VAS DRESSING

cod	litri	lei
785010	1	<b>43,99</b>



### MULTI-STATIV

- Cadru realizat din otel inoxidabil AISI 304 lustruit.
- 3 niveluri, pentru produse si condimente preambalate.
- 3 recipiente detasabile de 1 L, confectionate din plastic SAN.
- Recipientele pot fi spalate in masina de spalat vase.

cod	mm	lei
428245	190x240x(H)410	<b>249,99</b>





### TAVA TACAMURI

- 4 sectiuni
- GN 1/1

cod	culoare	mm	lei
552315	Negru	530x325x(H)100	49,99
552308	Gri	530x325x(H)100	44,99



552315



552308



### TAVA TACAMURI

- 6 sectiuni
- Potrivit pentru lingurite cafea, lingurite ceai si furculite tort
- GN 1/1

cod	culoare	mm	lei
552353	Gri	530x325x(H)105	49,99
552360	Negru	530x325x(H)105	49,99



552360



552353

### SUPORT PENTRU COS TACAMURI

- Pentru 4 cosuri
- Cosurile nu sunt incluse



cod	mm	lei
552407	255x295x(H)215	159,99



552407

### COS TACAMURI

cod	mm	lei
871201	ø97x(H)137	8,99



871201



552490

### COS TACAMURI

cod	mm	lei
552490	ø97x(H)137	25,99



### SUPORT PENTRU TACAMURI

- Fabricat din otel inoxidabil
- Design perforat care permite uscare rapida
- Potrivit pentru masina de spalare vase

cod	mm	lei
552483	ø110x(H)130	14,99



552483

**NOU**



436103

**TAVA PENTRU SERVIRE GN 1/1**

- Lustruit, cu margine mata.
- Fabricat din otel inoxidabil.
- Adecvat pentru tava de racire 424186.

cod	mm	lei
436103	530x325x(H)13	85,99



807705

**TAVA BANCHET GN 1/1 CU MARGINE NETEDA**

cod	mm	lei
807705	530x325x(H)10	109,99



410110

**TAVA SERVIRE GN 1/1**

cod	mm	lei
410110	530x325x(H)20	39,99



809181

**TAVA SERVIRE SUPERPOZABILA GN 1/1**

- Cu manere
- Distanta dintre tavile stivuite 40 mm.

cod	mm	lei
809181	530x325x(H)70	174,99



405000

**TAVA OVALA CAFEA**

- Finisaj satinat

cod	mm	lei
405000	200x140	12,99
405208	265x195	20,99
405307	285x220	25,99



480106

**TAVA BERE**

cod	mm	lei
480106	ø315x(H)45	49,99



### TAVA SERVIRE

- Slefuita



cod	mm	lei
480205	ø300x(H)17	29,99
480403	ø400x(H)19	49,99



807804



### TAVA BANCHET GN 1/1, CU RAMA DECORATIVA

- Fabricat din otel inoxidabil cu finisaj lucios.
- Margine ornata cu modele decorative imprimate in relief.
- Poate fi spalata in masina de spalata vase.
- Adecvat pentru tava de racire HENDI (cod: 424186).

cod	mm	lei
807804	530x325	99,99



871829



### TAVA PREZENTARE CU RACIRE

- Fabricat din otel inoxidabil.
- Cu o margine profilata care fixeaza capacul.
- Se potriveste in set: tava de racire HENDI cu capac (cod: 424155) si tavile display cu racire HENDI (coduri: 871805 si 871812).

cod	mm	lei
871829	395x283	59,99

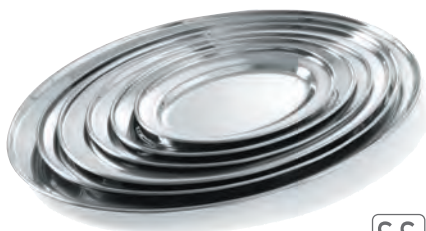

### TAVA SERVIRE OVALA

cod	mm	lei
404003	190x140	14,99
404102	245x170	18,99
404201	300x220	24,99
404300	350x240	31,99
404409	400x260	38,99
404508	450x290	44,99
404607	500x350	54,99



## TAVI FIBRA DE STICLA

- Poliester armat cu fibra de sticla
- Ideal pentru utilizare intensiva
- Suprafata din cauciuc non-alunecare, eficienta atat umeda cat si uscata
- Rezistent la socuri si lovituri



508657



508817



508718

## TAVA SERVIRE RECTANGULARA

- Neagra

cod	mm	lei
508657	200x280	29,99
508626	325x530	42,99
508619	Euronorm 370x530	52,99

## TAVA SERVIRE ROTUNDA

- Neagra

cod	mm	lei
508824	ø280x(H)22	25,99
508817	ø350x(H)22	34,99
508800	ø400x(H)22	44,99
508794	ø460x(H)22	54,99
508787	ø500x(H)22	79,99

## TAVA SERVIRE, OVALA

- Neagra

cod	mm	lei
508718	160x230	16,99
508725	200x265	22,99
508732	210x290	23,99



508831



## TAVA SERVIRE OVALA XL

- Neagra

cod	mm	lei
508831	735x600	140,99

810507

## SUPPORT TAVA PLIABIL

- Materiale de inalta calitate, constructie solida.
- Prevezut cu curele negre, usor de configurat.
- Cu inele anti-alunecare din cauciuc pentru a mentine tava in pozitie.

cod	mm	lei
810507	520x410x(H)800	239,99

MODEL  
NOU



## IMITATIE GRANIT



876619



### TAVA DIN POLIESTER PENTRU RESTAURANTE CU AUTOSERVIRE

- Fabricat din laminat de poliester (fibresticla, rasina).
- Culoare si model granit.
- Pot fi stivuite, cu spatiu intre tavi lasat pentru a mentine circulatia aerului.
- Rezistenta la temperatura: -10-120 °C.
- Potrivit pentru masina de spalat vase.

cod	culoare	mm	lei
876602	Grafit	325x265	29,99
876619	Granit	530x325	36,99

Spatiu intre tavi pentru o mai buna circulatie a aerului.

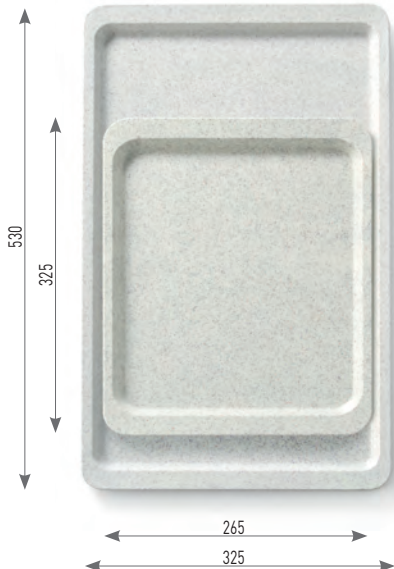

## TAVI FAST FOOD

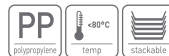

## TAVA MEDIE FAST FOOD

cod	culoare	mm	lei
878903	Gri	305x415x(H)20	16,99
878910	Rosu	305x415x(H)20	16,99
878927	Albastru	305x415x(H)20	16,99
878934	Verde	305x415x(H)20	16,99
878941	Maro	305x415x(H)20	16,99
878958	Negru	305x415x(H)20	16,99

## TAVA MARE FAST FOOD

cod	culoare	mm	lei
878804	Gri	350x450x(H)20	19,99
878811	Rosu	350x450x(H)20	19,99
878828	Albastru	350x450x(H)20	19,99
878835	Verde	350x450x(H)20	19,99
878842	Maro	350x450x(H)20	19,99
878859	Negru	350x450x(H)20	20,99

## TAVA MICA FAST FOOD

cod	culoare	mm	lei
878712	Rosu	265x345x(H)20	15,99
878705	Gri	265x345x(H)20	15,99
878729	Albastru	265x345x(H)20	15,99
878736	Verde	265x345x(H)20	15,99
878743	Maro	265x345x(H)20	15,99
878750	Negru	265x345x(H)20	15,99



878552

## TAVA PENTRU ALIMENTE RAPIDE DIN POLIPROPILENA, OVALA

- Oval, cu fanta joasa.
- Fabricat din polipropilena.

cod	culoare	mm	lei
878552	Negru	265x195x(H)15	8,49



## EURONORM DIN POLIPROPILENA



878101



878125



878606

### TAVA SERVIRE RECTANGULARA

cod	mm	lei
878118	255x355	<b>24,99</b>
878101	530x325	<b>35,99</b>

### TAVA SERVIRE ROTUNDA

cod	mm	lei
878125	ø280x(H)20	<b>17,99</b>
878132	ø360x(H)20	<b>24,99</b>
878149	ø410x(H)20	<b>28,99</b>

### TAVA SERVIRE ROTUNDA CU MARGINE INALTA

cod	mm	lei
878606	ø320x(H)37	<b>29,49</b>
878408	ø360x(H)39	<b>33,99</b>

## LEMN

- Tavi laminate cu strat de cauciuc antiderapant.
- Rezistent la substante chimice, pete si zgarieturi.



507216



507933



507711

### TAVA SERVIRE

cod	mm	lei
507216	325x530	<b>69,99</b>
507469	330x430	<b>62,99</b>
507025	460x360	<b>69,99</b>
507117	370x530	<b>69,99</b>
507018	430x610	<b>89,99</b>

### TAVA SERVIRE

cod	mm	lei
507964	230x160	<b>32,99</b>
507568	200x265	<b>31,99</b>
507933	290x210	<b>39,99</b>

### TAVA SERVIRE

cod	mm	lei
507711	ø320x(H)35	<b>74,99</b>
507766	ø360x(H)30	<b>94,99</b>
507773	ø420x(H)30	<b>109,99</b>

## TAVA SERVIRE DIN MELAMINA CU ASPECT DE LEMN

- Din melamina, strat acoperire cu aspect de lemn
- Rezistenta excelenta la substante chimice, pete si zgarieturi
- Disponibila in 3 modele diferite

cod	culoare	mm	lei
508916	Lemn	240x340	<b>39,99</b>
508862	Lemn deschis	330x430	<b>62,99</b>
508879	Lemn	330x430	<b>62,99</b>
508947	Lemn	370x530	<b>75,99</b>



508862



508947

508916



## TAVI DE SERVIRE ANTIALUNECARE CU IMPRIMEU

- Tavi laminate cu strat de cauciuc antiderapant.
- Rezistent la substante chimice, pete si zgarieturi.



507971

### TAVA DE SERVIRE ANTIDERAPANTA, ROTUNDA, CU IMPRIMARE

cod	mm	lei
507971	ø380x(H)15	74,99



508015



508008

### TAVA DE SERVIRE DREPTUNGHILARA SUPRAFATA ANTIALUNECARE, CU IMPRIMARE

cod	mm	lei
508008	330x430	74,99
508015	330x430	74,99
508022	330x430	74,99



508022





201633



Alarm:



sunet



lumina LED



vibratii

ABS  
plastic

### STATIE CENTRALA PAGERE

- Afisaje digitale pe pagere pentru marcarea ordinii/numarului mesei (numere programabile de la 001 la 998).
- Controler cu tastatura tactila.
- Antena integrata in controler, care izoleaza interferente de semnal de la alte dispozitive.
- 3 moduri de notificare: vibratii, sunet, lumina LED.
- Combinarea modurilor de notificare - toate dezactivate cu un singur clic.
- Incarcare care economiseste spatiu: pagerele sunt stivuite pe incarcator.
- Raza de actiune: 500 m.
- Dimensiunile Pagerului: 65 x 65 x 15 mm.
- Nr. max. de pagere programabile intr-un controler: 998.
- Inclus in set: controler, 10 pagere, statie de incarcare, incarcator.
- Pagerele se comercializeaza si separat - 10 buc. (cod: 201640).

cod	mm	lei
201633	210x130x(H)40	1119,00

### PAGERE RESTAURANT - SET DE 10 BUC.

- Afisaje digitale pe pagere pentru marcarea comenzii/numarului mesei (numere programabile de la 001 la 998).
- 3 moduri de notificare: vibratii, sunet, lumina LED.
- Combinarea modurilor de notificare - toate dezactivate cu un singur clic.
- Incarcare care economiseste spatiu: pagerele sunt stivuite pe incarcator.
- Raza de actiune: 500 m.
- Dimensiunile Pagerului: 65 x 65 x 15 mm.
- Inclus in set: 10 pagere, statie de incarcare, cablu USB-C.
- Paginile functioneaza numai cu controlerul din sistemul de apelare a restaurantului HENDI - vandut separat (cod: 201633).

cod	mm	lei
201640	80x80x(H)100	999,99



## MOBILIER PLIABIL PENTRU CATERING

- Usor de depozitat si transportat, mobilier pliabil pentru utilizare in exterior si in interior.
- Ideal pentru targuri, evenimente, catering, inchiriere etc.
- Suprafata de masa din polietilena, cadru din metal pulverizat.
- Usor de curatat si rezistent la murdarie.

**AMER★BOX®**

HDPE  
polietilena

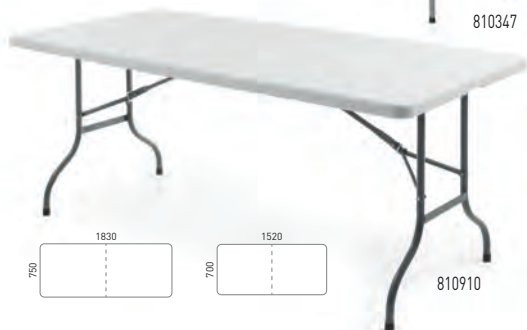

### MASA BUFET

- Model pliabil la dimensiunile unei valize, transport si depozitare usoare

cod	mm	lei
810927	1520x700x(H)740	309,99
810910	1830x750x(H)740	349,99

**AMER★BOX®**

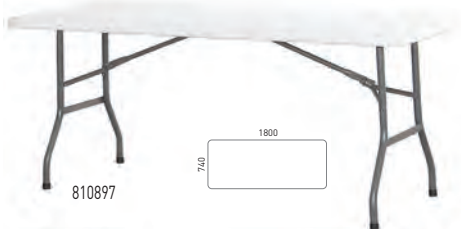

### MASA BUFET

- Prin aplicarea cu PVD, acoperirea neagra.
- Calitate ridicata si durabila.

cod	mm	lei
810347	870x870x(H)740	199,99
810897	1800x740x(H)740	359,99



### CARUCIOR PENTRU MESE

- Usureaza transportul meselor rotunde si patrate.
- Poate sustine pana la 10 mese rotunde in pozitie verticala sau peste 20 de mese dreptunghiulare stivuite.
- Incarcare maxima: 500 kg.

cod	mm	lei
811221	1800x850x(H)990	894,99





### MASA ROTUNDA DE BAR

cod	mm	lei
810958	ø800x(H)1100	299,99

**AMER★BOX®**



### MASA BUFET

cod	mm	lei
810934	1220x610x(H)740	249,99



813157



813164

### HUSA PENTRU MASA DE BAR Ø80-85 CM

- Material: Jersey simplu 160 g/m<sup>2</sup>.
- 90% micro poliester / 10% elastan.
- Nu este necesara calcarea.
- Se potriveste la mesele de bar cu diametru de ø80-85 cm.

**OEKO-TEX®**  
CONFIDENCE IN TEXTILES

cod	culoare	mm	lei
813157	Alb	ø850x(H)1150	99,99
813164	Negru	ø850x(H)1150	99,99



813829



813836

### HUSA PENTRU MASA DE BAR Ø70-85 CM

- Material: Jersey simplu 160 g/m<sup>2</sup>.
- 90% micro poliester / 10% elastan.
- Nu este necesara calcarea.
- Se potriveste la mesele de bar cu diametru de ø70 cm.

**OEKO-TEX®**  
CONFIDENCE IN TEXTILES

cod	culoare	mm	lei
813829	Alb	ø850x(H)1150	102,99
813836	Negru	ø850x(H)1150	102,99

### HUSE PENTRU MASA SIMPOZION DREPTUNGIULARA

- Material: Easy-Jersey 160 g/m<sup>2</sup>.
- 90% micro poliester / 10% elastan.
- Nu este necesara calcarea.
- Se potriveste cu mese tip bufet dreptunghiulare.

cod	culoare		mm	lei
814369	Alb	810934	1200x760x(H)730	133,99
814376	Negru	810934	1200x760x(H)730	133,99
814390	Alb	810927	1500x760x(H)730	149,99
814406	Negru	810927	1500x760x(H)730	149,99
814420	Alb	810910 810897	1830x760x(H)730	159,99
814437	Negru	810910 810897	1830x760x(H)730	159,99



814437

814420



810941



### MASA BUFET PLIABILA

- Model pliabil tip valiza pentru transport si depozitare usoara.

cod	mm	lei
810996	ø1500x(H)740	<b>599,99</b>
810941	ø1800x(H)740	<b>899,99</b>



814451

814468

### HUSE PENTRU MASA SIMPOZION ROTUNDA

- Material: Easy-Jersey 180 g/m<sup>2</sup>.
- 90% micro poliester / 10% elastan.
- Nu este necesara calcarea.
- Se potriveste cu mese rotunde de bufet.



cod	culoare	-	mm	lei
814451	alb	810941	ø1800x(H)760	<b>214,99</b>
814468	negru	810941	ø1800x(H)760	<b>214,99</b>



811191



### BANCA

- Model pliabil tip valiza pentru transport si depozitare usoara.

cod	mm	lei
811191	1830x300x(H)430	<b>209,99</b>

### SCAUN CATERING

- Incarcatura max. de pana la 180 kg cu distributie uniforma a incarcaturii

cod	mm	lei
810965	540x440x(H)840	<b>115,99</b>

### SCAUN CATERING - NEGRU

- Incarcatura max. de pana la 180 kg cu distributie uniforma a incarcaturii

cod	mm	lei
810989	540x440x(H)840	<b>149,99</b>



810965



810989



## STALP CU CORDON DE DELIMITARE RETRACTABIL CU FINISAJ TIP OGLINDA

- Bariera cu centura retractabila integrata.
- Usor de configurat, centura este conectata la stalp cu un sistem de prindere.

cod	-	mm	lei
810378	stalp + baza	ø360x(H)1010	249,99
810422	stalp	ø64x(H)935	139,99
810484	baza	ø360x(H)65	130,99

810378



S.S.  
stainless steel



## CORDON DE DELIMITARE

- Fabricat din franghie durabila cu carlige din otel inoxidabil la fiecare capat.
- Pentru utilizare in combinatie cu stalpi.

cod	-	mm	lei
810453	rosu cu cartig lustruit	1500	93,99
810460	albastru cu cartig lustruit	1500	93,99

810460

810453



BAR



# BARUP

B A R W A R E

Descoperiti lumea accesoriilor profesionale pentru bar.

Impartasim cunostintele noastre prin prezentarea unor produse inovatoare si proiectate profesional pentru configuratii complete de bar.

Designul nostru, inspirat din cele mai bune practici de bartending, reprezinta un raspuns profesional la lumea creativa si in continua schimbare a pregatirii cocktailurilor.

Functionalitatea si designul modern al shakerelor noastre, lingurilor de bar si storcatoarelor de citrice raspund perfect nevoilor fiecarui barman.

Brandul BAR UP inseamna accesorii atragatoare care ridica la un nivel superior arta prepararii bauturilor alcoolice si non-alcoolice si cocktailurilor.

BAR UP! BE INSPIRED!



## DISPOZITIVE DESCHIDERE STICLE

**NOU**

**NOU**

**BARUP**  
BARWARE



596746



### LAMA BAR

cod	mm	lei
596746	179x40x(H)2	<b>8,99</b>

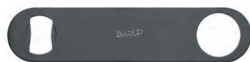

596388



### LAMA BAR

- Acoperire cu pulbere neagra.
- Nu poate fi spalat in masina de spalat vase.

cod	mm	lei
596388	180x40	<b>16,99</b>



596371



### LAMA BAR

- Finisaj cupru.
- Nu poate fi spalat in masina de spalat vase.

cod	mm	lei
596371	180x40x(H)2	<b>29,99</b>



Vezi filmul



643914



### DESFACATOR STICLE CU RECIPIENT CAPACE

- Acest dispozitiv de deschidere a sticlelor este destinat a fi montat pe perete
- Recipientul poate fi indepartat usor pentru golire
- Livrat cu doua suruburi si prize de perete

cod	mm	lei
643914	135x70x(H)295	<b>51,99</b>



596883

### DESCHIZATOR DE STICLE MONTAT PE PERETE

cod	lei
596883	<b>10,99</b>



595572



### PERFORATOR CAPAC STICLA

- Prikit
- Perforeaza cu usurinta capace de sticla si conserve, cu un orificiu de 6,5 mm
- Utilizarea impreuna cu un pai tine insectele departe de bauturi
- Reduce scurgerile daca sticla este rasturnata

cod	mm	lei
595572	ø45x(H)80	<b>50,99</b>

BAR





596807



### TIRBUSON CHELNER

- Placat cu crom, cu maner ABS
- 4 functii
- Cu desfacator separat de sticle

cod	mm	lei
596807	(L)140	12,99



597200



### TIRBUSON CHELNER

- Model curbat
- 3 functii

cod	mm	lei
597200	(L)110	14,99

Cutit folie

BARUP  
BARWARE

597323



### TIRBUSONUL OSPATARULUI

- Fabricat din otel inoxidabil, maner ABS.
- 3 functii.
- Parghie patentata, spirala pentru dopuri de pluta lungi si taietor de folie.

cod	mm	lei
597323	37x130x(H)14	33,99



597507



### TIRBUSON

- Model cu maneta
- Placat cu crom
- Cu desfacator sticle

cod	mm	lei
597507	(L)170	23,99



594018



### TIRBUSON CHELNER

- 3 functii
- Maner la indemana - carcasa rezistenta din polipropilena

code	mm	lei
594018	110x25	11,99



Perfect pentru  
destuparea  
sticlelor cu  
dopuri lungi



Vezi filmul

### TIRBUSON CHELNER

- Cu maner metalic
- 3 functii
- Cu nod suplimentar in maneta pentru dopuri lungi



cod	mm	lei
597316	(L)120	24,99



NOU

594025

### TIRBUSON FRANCEZ

- Fabricat din otel inoxidabil, calitate superioara garantata si fara risc de indoire sau rupere
- Manerul este cromat; spirala este nichelata
- Spirala tirbusonului este mai lata decat cele traditionae - reducerea riscului de strivire sau rupere a plutei in momentul extragerii dopului

cod	mm	lei
594025	105x85x(H)10	19,99



## PICURATOARE

**BARUP**  
 BARWARE

**PICURATOR CU CAPAC  
 RABATABIL - 6 BUCATI**

18/8

stainless steel

- Pentru utilizare in baruri, pub-uri si restaurante
- Facilitatea dozarea precisa
- Fabricat din otel inoxidabil cu dop din cauciuc
- Adecvat pentru sticle standard de 0,5 - 1,5 litri cu orificii cu diametru de pana la ø20 mm

cod	ambalat pe	mm	lei
599334	6	ø30x120	<b>35,99</b>

599334



599372

**PICURATOR FREE-FLOW - 6 BUCATI**

- Plastic EVA

cod	ambalat pe	lei
599372	6	<b>25,99</b>



599488

599464

599471



593363

**PICURATOR LONG FLOW, CUPRU**

- Fabricat din otel inoxidabil cu invelis din cupru.
- Stopper din plastic.

S.S.

stainless steel

cod	ambalat pe	lei
593363	12	<b>147,99</b>

**PICURATOR STICLE TIP  
 FREE-FLOW, SET 6 BUC**

18/8

stainless steel



cod		ambalat pe	lei
599488	Picurator sticle, tip fast-flow	6	<b>30,79</b>
599464	Picurator sticle, tip slow-flow	6	<b>31,29</b>
599471	Picurator sticle, tip flip-top	6	<b>31,09</b>



590140

**PICURATOR FREE-FLOW - LUNG**

- Stopper din plastic.

cod	lei
590140	<b>8,99</b>



18/8

stainless steel

**PICURATOR CU CAPAC**

- Pentru utilizare in baruri, pub-uri si restaurante
- Constructie rezistenta din otel inoxidabil
- Clapeta de turnare contrabalansata, care face ca duza sa se deschida si sa se inchida automat atunci cand sticla este inclinata
- Facilitatea dozarea precisa
- Adecvat pentru sticle standard de 0,5 - 1,5 litri cu orificii cu diametru de pana la ø20 mm

cod	ambalat pe	mm	lei
599327	3	ø30x120	<b>29,99</b>

599327



599402 599419 599426 599433

### PICURATOR FREE-FLOW - 4 BUCATI

- Plastic EVA

cod	-	ambalat pe	lei
599402	Albastru	4	22,99
599419	Rosu	4	22,29
599426	Transparent	4	22,99
599433	Galben	4	22,99



599440 599457

### PICURATOR CU FLUX LIBER

- Fabricat din material EVA.

cod	-	ambalat pe	lei
599440	2 negre, 2 albe, 2 rosii	6	8,59
599457	2 albastre, 2 rosii, 2 verzi	6	8,99



598719 598818  
montare pe perete montare pe raft



### SUPORT NON-PICURARE MONTARE PE PERETE

- Pentru sticle cu inaltimea cuprinsa intre 240 mm si 350 mm

cod	-	lei
598719	montare pe raft	49,99
598818	montare pe perete	49,99



598009 598207 598405

### SISTEM ANTI-PICURARE

cod	ml	lei
598009	25	32,99
598207	35	32,99
598405	50	32,99



599006 599105 599204

### PICURATOR CU BILA PENTRU DOZARE CANTITATE

ABS  
plastic

cod	-	lei
599006	25 ml	13,99
599105	35 ml	13,99
599204	50 ml	13,99



552049

### DOP FLACON – 3 BUC.

- Previne scurgerile si scurgerile de bauturi
- Sigiliul ermetic prelungeste durata de viata a produsului intr-o sticla deja deschisa
- Fabricat din nailon cu o maneta ABS foarte durabila
- Inel de silicon integrat care sigileaza strans sticla atunci cand este apasata maneta
- Adecat pentru sticle standard cu o capacitate de 0,5 - 1,5 litri, orificii cu diametrul de pana la  $\varnothing 20$  mm
- Include 3 capace in culorile verde, alb si rosu

cod	ambalat pe	mm	lei
552049	3	$\varnothing 36 \times 81$	24,99



595589



### DOP SAMPANIE

- Pentru depozitarea sticlelor desfacute
- Cu garnitura din silicon

cod	lei
595589	15,99



595558

### STOPER – 6 BUC.

- Pentru utilizare in baruri, pub-uri si restaurante
- Realizata din EVA negru dur si flexibil
- Protejati impotriva varsarii sticlelor deschise
- Inchidere etansa pentru prelungirea duratei de viata a produsului
- Adecat pentru sticle standard de 0,5 - 1,5 litri cu orificii cu diametru de pana la  $\varnothing 20$  mm

cod	ambalat pe	mm	lei
595558	6	$\varnothing 31 \times 31$	12,99



595565

### STOPER CU CAPAC – 6 BUC.

- Pentru utilizare in baruri, pub-uri si restaurante
- Protejati impotriva varsarii sticlelor deschise
- Fabricat din EVA dur si flexibil
- Inchidere etansa pentru prelungirea duratei de viata a produsului
- Adecat pentru sticle standard de 0,5 - 1,5 litri cu orificii cu diametru de pana la  $\varnothing 20$  mm

cod	ambalat pe	lei
595565	6	17,99



557600



### RECIPIENT BAR

- Cioc si capac interschimbabile
- Pentru depozitarea, amestecarea si servirea bauturilor
- Partea superioara detasabila

cod	litri	mm	lei
557600	0.8	$\varnothing 90 \times (H) 300$	27,99





588420

### APARAT FRISCA KITCHEN LINE NEGRU

- Recipient din aluminiu acoperit cu negru mat, suport pentru incarcator si capac
- Set de 3 duze din polipropilena si o perie de curatare
- Nu este adecvat pentru sosuri fierbinti
- Necesita incarcator (N<sub>2</sub>O) pentru a functiona, nu este inclus

cod	litri	mm	lei
588420	0.5	ø80x(H)260	134,99
588598	0.95	ø95x(H)320	221,99



### CARTUSE PENTRU APARAT FRISCA

- Universal pentru Liss, Kidde, Kaiser, ISI, etc
- N<sub>2</sub>O
- Termen de valabilitate 5 ani de la data fabricatiei

cod	ambalat pe	lei
588208	10	15,99
588215	24	39,99
586907	50	84,99



588574

588420

### RECIPIENT SIFON

- Recipient sifon din otel inoxidabil
- Produce apa carbogazoasa in cel mai scurt timp
- Necesita cartuse cu dioxid de carbon pentru utilizare

cod	litri	mm	lei
588574	1	ø100x(H)320	339,99



588406

### CARTUSE SIFON - 10 BUCATI

- Contine 8 gr CO<sub>2</sub>, pentru 1 lt sifon

cod	ambalat pe	lei
588406	10	21,99



## CUTIE INGREDIENTE



**BARUP**  
BARWARE

- Pentru utilizare in baruri, pub-uri si restaurante
- Fabricat din materiale plastice premium
- Carcasa HIPS si capac ABS transparent pentru protejarea alimentelor impotriva contaminarii sau insectelor
- 3 recipiente din polipropilena pentru depozitarea separata a aditivilor pentru fructe sau condimente
- Fiecare recipient poate fi scos cu usurinta din suport, pentru curatare sau reaprovizionare
- Recipiente care pot fi spalate in masina de spalat vase



552018



552025



552131



552032

### CUTIE PENTRU INGREDIENTE - 3 RECIPIENTE

- 3 recipiente din polipropilena pentru depozitarea separata a fructelor sau condimentelor

code	mm	lei
552018	480x150 x(H)100	<b>78,99</b>

### CUTIE PENTRU INGREDIENTE - 4 RECIPIENTE

- 4 recipiente din polipropilena pentru depozitarea separata a fructelor sau condimentelor

code	mm	lei
552025	480x150 x(H)100	<b>80,99</b>

### CUTIE PENTRU INGREDIENTE - 5 RECIPIENTE

- 5 recipiente din polipropilena pentru depozitarea separata a fructelor sau condimentelor

code	mm	lei
552131	480x150 x(H)100	<b>95,69</b>

### CUTIE PENTRU INGREDIENTE - 6 RECIPIENTE

- 6 recipiente din polipropilena pentru depozitarea separata a fructelor sau condimentelor

code	mm	lei
552032	480x150 x(H)100	<b>83,99</b>

BAR



552100

### CUTIE INGREDIENTE

- Otel inoxidabil cu capac din polipropilena, transparent
- Include 5 containere albe din polipropilena pentru depozitare

cod		mm	lei
552100	5 containere	375x140x(H)90	<b>104,99</b>



596890

### SUPPORT PENTRU SERVETELE CU 3 COMPARTIMENTE

- Pentru utilizare in orice unitate alimentara si de bauturi
- Fabricat din polistiren
- Compartiment mare pentru servetele de masa 135x135 mm
- Doua compartimente mai mici cu dimensiuni de 24x115 mm pentru paie, agitatoare etc.

cod	mm	lei
596890	193x143x(H)136	25,99



826348

826485



### TOCATOR CU MANER

- Fabricat din polietilena HDPE.
- Ambele parti potrivite pentru taiere.

cod	culoare	mm	grosime (mm)	lei
826348	Alb	250x150	10	17,99
826478	Negru	250x150	10	19,99
826355	Alb	300x200	10	29,99
826485	Negru	300x200	10	30,99

BARUP  
BARWARE



596760

ABS  
plastic

### BAR CADDY

- 6 compartimente pentru organizare servetele, paie, agitatoare, etc.
- Compartiment servetele 130x130 mm

cod	mm	lei
596760	240x145x(H)105	34,59



596777

ABS  
plastic

### SET DECORARE PAHARE COCKTAIL

- Pentru decorare margine pahare
- 3 zone: suc lime, sare, zahar
- Burete pentru suc lime, pentru a evita stropirea

cod	mm	lei
596777	200x160x(H)75	36,99

**NOU**

596685



596524

**NOU**

596531

**NOU**

596753



596456



596463

**SITA COCKTAIL**

cod	mm	lei
596685	160x75	9,99

**FILTRU JULEP**

- Acoperire de cupru cu finisaj lucios.
- Nu poate fi spalat vase.

cod	mm	lei
596524	160x75	36,99

**FILTRU JULEP**

- Acoperire cu pulbere neagra.
- Nu poate fi spalat vase.

cod	mm	lei
596531	160x76	24,99

**FILTRU HAWTHORNE**

- Poate fi spalat in masina de spalat vase.

cod	mm	lei
596753	82x28x(H)165	17,99

**FILTRU HAWTHORNE**

- Finisaj cupru lucios.
- Nu poate fi spalat in masina de spalat vase.

cod	mm	lei
596456	160x75x(H)15	29,99

**FILTRU HAWTHORNE**

- Acoperire cu pulbere neagra.
- Nu poate fi spalat in masina de spalat vase.

cod	mm	lei
596463	160x75x(H)15	24,99

BAR



596449

**NOU****FILTRU COCKTAIL TRIUNGHIULAR**

- Fabricat din otel inoxidabil.
- Are detasabil pentru o curatare usoara.
- Cu un orificiu in maner.
- Poate fi spalat in masina de spalat vase.

cod	mm	lei
596449	97x105	27,99



**NOU****NOU****BARUP**  
BARWARE**NOU****NOU**

596968



596555



596562



593097



596579



596586

**LINGURA DE BAR**

cod	mm	lei
596968	(L)380	17,99

**LINGURA DE BAR**

- Finisaj cupru lucios.
- Nu poate fi spalat in masina de spalat vase.

cod	mm	lei
596555	385x35	45,99

**LINGURA DE BAR**

- Acoperire cu pulbere neagra.
- Nu poate fi spalat in masina de spalat vase.

cod	mm	lei
596562	385x35	29,99

**LINGURA DE BAR CU CAP PLAT**

- Poate fi spalat in masina de spalat vase.

cod	mm	lei
593097	280x35	13,99

**LINGURA DE BAR CU CAP PLAT**

- Acoperire din cupru cu finisaj lucios.
- Nu poate fi spalat in masina de spalat vase.

cod	mm	lei
596579	280x35	29,99

**LINGURA DE BAR CU CAP PLAT**

- Acoperire cu pulbere neagra.
- Nu poate fi spalat in masina de spalat vase.

cod	mm	lei
596586	280x35	31,99



**BARUP**  
BARWARE**NOU****S.S.**  
stainless steel**SITE - SET DE 3 BUC.**

- Fabricat din otel inoxidabil AISI204 vopsit prin pulverizare.
- Cu un suport mic pentru a pune sita pe o oala sau un bol sau pentru a o agata.
- Dimensiuni:
  - sita de culoare neagra: ø74 mm, (L) 215 mm, (H) 25 mm,
  - sita de culoare argintie: ø105 mm, (L) 245 mm, (H) 30 mm,
  - sita colorata in cupru: ø144 mm, (L) 337 mm, (H) 45 mm.
- Lungime maner:
  - sita de culoare neagra: 115 mm,
  - sita de culoare argintie: 120 mm,
  - sita colorata in cupru: 165 mm.
- Dimensiune sita:
  - sita de culoare neagra: 1x1 mm,
  - sita de culoare argintie: 1x1 mm,
  - sita colorata in cupru: 1,5x1,5 mm.
- Nu poate fi spalat in masina de spalat vase.

cod	lei
635612	56,99

**SITA DE BAR**

- Pentru utilizare in baruri, pub-uri, restaurante si patiserie
- Fabricat din otel inoxidabil
- Plasa subtire cu maner metalic
- Poate fi spalat in masina de spalat vase

cod	mm	lei
638118	ø65x220	5,59

**SITA BAR ACOPERITA CU PVD**

- Pentru utilizare in baruri, pub-uri, restaurante si patiserie
- Otel inoxidabil finisat cu strat de acoperire din PVD negru elegant
- Plasa subtire cu maner metalic
- NOTA: Nu poate fi spalat in masina de spalat vase

cod	mm	lei
638132	ø65x220	10,99
638149	ø75x220	11,99

**SITA BAR CONICA ACOPERITA CU PVD**

- Pentru utilizare in baruri, pub-uri, restaurante si patiserie
- Otel inoxidabil finisat cu strat din PVD negru elegant
- Plasa subtire cu maner metalic
- NOTA: Nu poate fi spalat in masina de spalat vase

cod	mm	lei
638170	ø75x220	14,99

**SITA BAR CONICA**

- Pentru utilizare in baruri, pub-uri, restaurante si patiserie
- Fabricat din otel inoxidabil
- Plasa subtire cu maner metalic
- Poate fi spalat in masina de spalat vase

cod	mm	lei
638163	ø75x220	7,99

BAR





**BARUP**  
BARWARE



596944



596739



596951

**ABS**  
plastic

### ZDROBITOR

- Fabricat din ABS neagra
- Pentru maruntirea si pasarea ingredientelor pentru bauturi, de exemplu, zmeura, lime, menta etc.
- Disponibil in versiuni: neted si profilat [stea]

cod		mm	lei
596739	profilat	ø34x207	<b>10,89</b>
596944	neted	ø34x207	<b>11,99</b>
596951	profilat, in forma de stea	ø34x207	<b>11,99</b>



521410

**AL**  
aluminium

### SCAFA GHEATA DIN ALUMINIU

cod	mm	lei
521410	220x80	<b>19,99</b>

521434

**AL**  
aluminium

### SCAFA GHEATA

cod	mm	lei
521434	220x80	<b>23,99</b>

### CLESTI CUBURI GHEATA

- Set de 2 bucati

cod	mm	lei
523520	(L)180	<b>15,99</b>

**S.S.**  
stainless steel



523520





593004

NOU



596425

NOU



596432

NOU



596401



593318

NOU



596418

### SHAKER COBBLER CU 3 PIESE

- Poate fi spalat in masina de spalat vase.

cod	litri	mm	lei
593004	0.75	ø80x(H)240	59,99

### SHAKER COBBLER CU 3 PIESE

- Acoperire din cupru cu finisaj lucios.

- Nu poate fi spalat in masina de spalat vase.

cod	litri	mm	lei
596425		ø85x(H)240	92,99

### SHAKER COBBLER CU 3 PIESE.

- Acoperire cu pulbere neagra.

- Nu poate fi spalat in masina de spalat vase.

cod	litri	mm	lei
596432		ø85x(H)240	79,99

### SHAKER BOSTON TIN-ON-TIN

- Poate fi spalat in masina de spalat vase.

cod	litri	mm	lei
596401	0.8	ø90x(H)303	64,99

### SHAKER BOSTON TIN-ON-TIN

- Finisaj cupru lucos.

- Nu poate fi spalat in masina de spalat vase.

cod	mm	lei
593318	ø90	134,99

### SHAKER BOSTON TIN-ON-TIN

- Acoperire cu pulbere neagra.

- Nu poate fi spalat in masina de spalat vase.

cod	mm	lei
596418	ø90	64,99



596982



596975

### CANA PLACATA CU CUPRU

cod	-	litri	mm	lei
596975	Cana	0.5	ø97x(H)100	35,99
596982	Cana de bere	0.4	ø85x(H)105	25,99



NOU



593035



593066



593042



596395



596678

### SHAKER COBBLER CU 3 PIESE

cod	litri	mm	lei
593035	0.75	ø90x(H)255	38,69

### STICLĂ PENTRU SHAKER BOSTON

- Fabricat din sticlă calită.
- Capacitate: 0,45 l
- Cupa vibratoare din oțel inoxidabil a pistonului poate fi achiziționată separat (coduri: 593042, 596678).

cod	litri	lei
593066	0.45	12,99

### SHAKER BOSTON

cod	litri	mm	lei
593042	0.8	ø90x(H)175	21,99

NOU



700259

### SHAKER BOSTON

cod	litri	lei
596678	0.8	29,99

### SHAKER BOSTON

- Acoperire lustruita in culoarea cuprului.
- Nu poate fi spalat in masina de spalat vase.

cod	mm	lei
596395	ø90	64,99

### GEANTA PENTRU ACCESORII PENTRU BAR

- Fabricat din bumbac gros cu tesatura simpla. Geanta are o margine cu cusatura dubla pentru intarire si un finisaj elegant.
- Fitinguri din oțel inoxidabil finisate in culori aurii vintage.
- Curele fabricate din piele naturala maro.
- Cureaua neagra din bumbac pentru umar reglabila in lungime si detasabila.
- Fixati dispozitivul de fixare cu ajutorul cataramelor si curelelor din piele.
- Oprire:
  - 8 buzunare (de ex. pentru lingurita pentru cocktail, penseta),
  - 8 compartimente elastice deschise (de ex., pentru cupa de masurare),
  - 3 clapete fixate cu velcro,
  - compartiment cu fermoar pentru un shaker/sticla pentru shaker, cu dimensiuni de 37x15 cm.
- Dimensiunile piesei interne (cu clapete inchise): 37x33,5 cm.

cod	mm	lei
700259	210x370x(H)70	173,99



25 ml  
596920



25 ml  
593332



25 ml  
596654



25 ml  
596722



25 ml  
596715



25 ml  
596548



25 ml  
596647

**NOU**

**S.S.**  
stainless steel

### CUPA MASURARE 25/50 ML

- Fabricat din otel inoxidabil
- Inel pentru greutate si stabilitate optima la nivelul mainii
- Cu doua fete, 25 ml si 50 ml

cod	mm	lei
596920	ø43x(H)110	12,99

### CUPA MASURARE 25/50 ML

- Fabricat din otel inoxidabil cu invelis din cupru cu finisaj lucios.
- Capacitati: 25/50 ml.
- Nu poate fi spalat in masina de spalat vase.

cod	mm	lei
596548	ø42x(H)86	36,99

### CUPA MASURARE 25/50 ML

- Fabricat din otel inoxidabil cu invelis lucios de culoare cupru.
- Prevazut cu un inel in benzi pentru o priza suplimentara.
- Capacitati: 25/50 ml.
- Nu poate fi spalat in masina de spalat vase.

cod	mm	lei
593332	ø43x(H)110	63,99

### CUPA MASURARE 25/50 ML

- Fabricat din otel inoxidabil cu strat de pudra neagra cu finisaj mat.
- Capacitati: 25/50 ml.
- Nu poate fi spalat in masina de spalat vase.

cod	mm	lei
596647	ø45x(H)86	15,99

### CUPA MASURARE 25/50 ML

- Pentru utilizare in baruri, pub-uri si restaurante
- Fabricat din otel inoxidabil
- Inel pentru greutate si stabilitate optima la nivelul mainii
- Culoare neagra eleganta
- Cu doua fete, 25 ml si 50 ml

cod	mm	lei
596654	ø45x(H)110	17,99

### CUPA MASURARE 25/50 ML

- Fabricat din otel inoxidabil cu finisaj mat.
- Capacitati: 25/50 ml.
- Poate fi spalat in masina de spalat vase.

cod	mm	lei
596722	ø43x(H)85	15,99

### CUPA MASURARE 25/35 ML

- Fabricat din otel inoxidabil.
- Capacitati: 25/35 ml.
- Poate fi spalat in masina de spalat vase.

cod	mm	lei
596715	ø40x(H)73	14,99



BAR



**NOU**

### BARKIT TUB

- Varful dispozitivului de prindere este fabricat din polipropilena (PP).
- Tub realizat din carton gros.
- Agitator Boston Tin-on-Tin: 2 cesti ponderate, cu capacitati de 500 ml si 800 ml.
- Cupa de masurare clasica cu capacitati de 50 ml si 25 ml.
- Filtru Hawthorne: cu un maner ergonomic si un arc detasabil. Se potriveste perfect pe shaker.
- Mudler: cu suprafata zimtata pentru zdrobirea rapida a bucatilor de fructe si plante aromatice.
- Lingura spiralata pentru bar cu lungimea de 27 cm si capacitatea de 5 ml, cu un cap plat: pentru amestecarea rapida a bauturilor fara diluarea acestora, turnarea bauturilor carbogazoase si crearea precisa a cocktailurilor stratificate. Capul plat poate fi utilizat si pentru zdrobirea fructelor si ierburilor aromatice.
- Setul este inserat intr-un tub de carton cu un imprimeu elegant.
- Toate elementele setului pot fi spalate in masina de spalat vase.



596616



596623



### BARKIT TUB

- Consta din 5 elemente, fabricate din otel inoxidabil AISI 201.

cod	mm	lei
596616	ø120x(H)320	162,99

### BARKIT TUB

- Consta din 5 elemente, confectionate din otel inoxidabil AISI 201 cu invelis lucios de culoare cupru.

cod	mm	lei
596623	ø120x(H)320	186,99





471500



**FRAPIERA PENTRU PETRECERE**

cod	litri	mm	lei
471500	13.5	ø370x(H)230	239,99



471524



**FRAPIERA SAMPANIE**

cod	litri	mm	lei
471524	9.5	ø350x(H)230	79,99



593165

**VAS PARTY**

- Transparent  
- Oval



cod	mm	lei
593165	470x290x(H)230	149,99



593158

**FRAPIERA VIN**

- Transparenta



cod	litri	mm	lei
593158	3	220x185x(H)226	69,99



593103

**FRAPIERA VIN**

- Cu manere laterale



cod	litri	mm	lei
593103	3.5	ø210x(H)210	50,99



593202

**FRAPIERA VIN**

- Cu manere laterale tip inel



cod	litri	mm	lei
593202	3.3	ø220x(H)190	39,99





### SUPORT FRAPIERA

- Ambalat compact
- Asamblare 4 piese

cod	mm	lei
593608	ø185x(H)750	299,99

593608



BARUP  
BARWARE

593905



### SUPORT PRINDERE FRAPIERA DE MASA

- Inel ø185 mm
- Frapiera nu este inclusa

cod	mm	lei
593905	ø195x(H)510	79,99



593806

Pentru  
utilizare  
fara cuburi  
de gheata



### FRAPIERA VIN

- Otel inoxidabil cu pereti dubli
- A se folosi fara cuburi de gheata

cod	mm	lei
593806	ø120x(H)180	59,99



Greutate redusa,  
dar foarte izolatoare



593813

### FRAPIERA VIN EPP

- Fabricata din EPP, material cu grad de izolare mare
- Cu stabilitate mare, rezistenta la spargere
- Temperatura vinului creste cu aprox. 1.5°C pe ora, pastreaza vinul rece mai mult timp decat frapierele obisnuite

cod	mm	lei
593813	ø142x(H)210	63,99



594742

### GALEATA PENTRU GHEATA CU PERETI DUBLI

cod	litri	mm	lei
594742	5	ø190x(H)200	59,99
594759	10	ø292x(H)220	159,99



594704



### GALEATA GHEATA CU PERETI DUBLI

cod	litri	mm	lei
594704	5	ø200x(H)230	317,99





679012

### FORMA CUBURI DE GHEATA DIFERITE DIMENSIUNI

- Ideale pentru cocktail-uri, pentru baruri profesionale
- Creeaza 6 cuburi de gheata
- Fabricate din silicon durabil, de calitate.

cod	mm	lei
679012	190x105x(H)30	31,99



BARUP  
BARWARE

679043



### FORMA CUBURI MICI DE GHEATA

- Ideal pentru bauturi reci si pentru baruri profesionale
- Creeaza 15 cuburi (=3x3x3 cm)
- Fabricat din silicon durabil, de calitate.

cod	mm	lei
679043	190x120x(H)35	29,09



679036



### FORMA CUBURI DE GHEATA XL

- Ideale pentru whiskey si pentru baruri profesionale
- Creeaza 6 cuburi mari (=5x5x5 cm) cu tipare lenta
- Fabricate din silicon durabil, de calitate

cod	mm	lei
679036	170x110x(H)52	32,09



Vezi filmul

679029



### FORMA CUBURI DE GHEATA

- Ideal pentru whiskey si pentru baruri profesionale
- Creeaza 6 bile mari (= 4,5 cm), cuburi de gheata care se topecs lent.
- Constă in 2 parti cu inel de blocare, astfel incat bilele pot fi facute fara scurgere.
- Fabricat din silicon durabil, de calitate

cod	mm	lei
679029	180x125x(H)50	46,39



679050



### FORMA CUBURI DE GHEATA

- Ideal pentru servirea shot-urilor si pentru baruri profesionale
- Creeaza 6 shot-uri in forma de pahar din cuburi de gheata
- Fabricat din silicon durabil, de calitate

cod	mm	lei
679050	125x190x(H)60	69,99



679067



### FORMA CUBURI DE GHEATA

- Ideal pentru servirea shot-urilor si pentru baruri profesionale
- Creeaza 4 shot-uri in forma de pahar din cuburi de gheata
- Fabricat din silicon durabil, de calitate

cod	mm	lei
679067	122x122x(H)60	38,99

### FORME GHEATA

- Profesional
- Cauciuc moale, cu suport
- 32 cuburi gheata

cod	mm	lei
679005	335x180	69,99



679005

Cauciuc moale in suport



274255



Vezi filmul



### APARAT PENTRU GRANITA.

- Recipient de 12 litri cu robinet de distribuire rapida, capace iluminate
- Controler digital de temperatura cu moduri de bauturi reci si de somn.
- Compresorul eficient, in modul de asteptare, variaza intre -10°C si -2°C.
- Recipientele pot fi scoase pentru a usura curatarea.
- Modul zi si noapte.
- Agent frigorific: R290.
- Tava de picurare inclusa.

cod	litri	V	W	mm	lei
274255	12	230	400	270x422x(H)815	6769,00



274224



### APARAT GRANITA 2 X 12 LT

- 2 recipiente de 12 lt cu robinet, capacele sunt luminate
- Control digital temperatura, setare tip bautura rece sau bautura granita
- Compresor eficient, in varianta granita temperatura variaza intre -10°C si -2°C
- Recipiente detasabile, pentru curatare usoara
- Mod zi si noapte
- Agent frigorific R290
- Tava scurgere inclusa

cod	litri	V	W	mm	lei
274224	24	230	740	470x515x(H)780	9599,00



### DISPENSER DE SUC 2X12 L

- Doua containere de 12 litri cu robinet rapid de distribuire.
- Regulatorul de temperatura, temperatura poate fi setata intre 0°C si 10°C.
- Containerele pot fi indepartate pentru a usura curatarea.
- Agent de racire: R290.
- Captuseala este inclusa.

cod	litri	V	W	mm	lei
425206	24	230	370	485x415x(H)645	3949,00



425206



Vezi filmul





289952



### APARAT PENTRU FABRICARE BERE - PANOU DE COMANDA DIGITAL

- Conceput pentru a prepara bere din malt la tine acasa.
- Mod manual pentru prepararea berii folosind propria reteta
- Mod de operare automata - 9 retete pot fi stocate in memoria dispozitivului, fiecare cu pana la 9 pasi de productie
- Panou usor de utilizat care afiseaza parametrii de functionare
- Gama de temperatura de incalzire: 25 ° C pana la 100 ° C, precisa la 0,1 ° C
- Pompa asigura o amestecare neteda si eficienta
- Gradarea in interiorul rezervorului (scara de 5 l) si indicatorul de pe tubul exterior de sticla (scara de 1 l) faciliteaza verificarea nivelului de umplere al rezervorului.
- Carcasa din otel inoxidabil AISI 304
- Baza care separa camera de fermentare de pompa si sectiunea de control este realizata din otel AISI 304
- Robinet.
- Capac de sticla.

cod	litri	V	W	mm	lei
289952	40	230	2500	ø400x(H)630	<b>1699,00</b>
289969	60	230	3000	ø400x(H)780	<b>2099,00</b>



289976



### RACITOR DE IMERSIE 10 ROTATII, Ø255 MM

- Proiectat pentru a raci maltul in timpul prepararii berii
- Teava din otel inoxidabil AISI 304
- Numar de rotatii: 10
- Inaltime: bobina 100 mm, inaltimea totala a racitorului 360 mm
- Diametru: exterior 255 mm
- Teava: lungime 8,8 m, diametru 9,5 mm
- Greutate neta: 1,25 kg
- Accesorii (289952, 289969)

cod	mm	lei
289976	ø255x(H)360	<b>267,99</b>



289983



### RACITOR DE IMERSIE 16 ROTATII, Ø255 MM

- Proiectat pentru a raci maltul in timpul prepararii berii
- Teava din otel inoxidabil AISI 304
- Numar de rotatii: 16
- Inaltime: bobina 290 mm, inaltimea totala a racitorului 485 mm
- Diametru: exterior 255 mm
- Teava: lungime 13 m, diametru 9,5 mm
- Greutate neta: 1,85 kg
- Accesorii (289952, 289969)

cod	mm	lei
289983	ø255x(H)485	<b>314,99</b>





Vezi fitmul



### DOZATOR BERE

- Plexiglas
- Cu robinet anti-picurare

cod	literi	mm	lei
598955	3	ø100x(H)815	319,99
598962	5	ø100x(H)1150	360,99

598962

598955



BARUP  
BARWARE

### GLISOR BERE - 6 BUCATI

- Plastic alb

cod	mm	lei
565360	235x26	25,29



565360



516751



### GALEATA PENTRU BERE

- Cu deschizator de sticle integrat in maner.

cod	mm	lei
516751	ø230x(H)180	49,99



### ECONOMIZOR DE VINURI CU VID

- Poate fi utilizat cu toate tipurile de vinuri (clasice si spumante) si sticle de vin: standard - 750 ml si mai mari - 1000 ml.
- Pompa si opritoare fabricate din ABS si TPE.
- Pompa elimina rapid aerul din sticla, creand sigiliul ermetic si vidul optim pentru pastrarea gustului si aromei timp de pana la 7 zile (la refrigerare).
- 2 dopuri incluse in set.
- Stopere prevazute cu un buton de eliberare a vidului - extragerea usoara a unui opritor.
- Pompa si opritoarele nu pot fi spalate in masina de spalat vase.

cod	mm	lei
595541	140x65x(H)50	45,99

ABS  
plastic



NOU



595541

596517



NOU

### SUPORT PENTRU PAHARE

- Fabricat din otel inoxidabil. Cu posibilitate de agatare sub un raft. 1 rand este destinat asezarii paharelor.
- Livrat cu suruburi si prize de perete

cod	mm	lei
596517	408x115x(H)30	27,99



NOU

696064

ABS plastic LDPE polyethylene PP polypropylene

### SPALATOR PHARE

- Pentru autoasamblare, destinat amplasarii pe chiuveta.
- Adecvat pentru pahare cu diametrul de 50-140 mm si inaltimea de max. 240 mm, inclusiv pahare de bere Stein German (cu ureche) sau pahare englezești.
- Carcasa fabricata din ABS, perii din polipropilena.
- Peria din mijloc este detasabila.
- Dotat cu un sistem telescopic de clatire in interiorul unuia dintre recipiente - are jeturi pentru clatirea paharelor, pulverizeaza in acelasi timp interiorul si exteriorul paharelor.
- Cu racord direct la apa - spalati eficient paharele in apa rece (sub 30 °C).
- Cu preaplin - util atunci cand apa in exces ajunge peste perii.
- Prevazut cu 4 picioruse de aspiratie din PVC, care asigura stabilitatea.
- Conform cu standardele HACCP.
- Nu sunt necesare proceduri de intretinere/service in afara intretinerii de baza pentru igiena.
- Inclus in set: furtun de alimentare cu apa de 3/8" cu lungimea de 70 cm.

cod	mm	lei
696064	370x200x(H)360	524,99

596500



NOU

### SUPORT SUSPENDAT PENTRU PAHARE

- Fabricat din otel inoxidabil.
- Cu posibilitate de agatare pe un perete.
- Livrat cu suruburi si prize de perete

cod	mm	lei
596500	350x293x(H)50	150,99





696002

**PERIE SPALARE PAHARE**

- Polipropilena cu 3 perii din nailon
- Placa de baza dotata cu 4 ventuze



cod	mm	lei
696002	190x100x(H)180	49,09



696040

**PERIE SPALARE PAHARE**

- Polipropilena cu 3 perii din nailon
- Placa de baza dotata cu 4 ventuze



cod	mm	lei
696040	190x100x(H)250	52,69



552681

**PERIE SPALARE PAHARE**

- Aluminiu cu perie din nailon
- Placa de baza dotata cu 4 ventuze



cod	mm	lei
552681	ø150x(H)190	89,99



597972

597989

**SUPTOR ANTI-ALUNECARE BAR**

cod	mm	lei
597989	300x150x(H)9	23,99
597965	610x85x(H)15	28,79
597972	453x305x(H)15	50,99

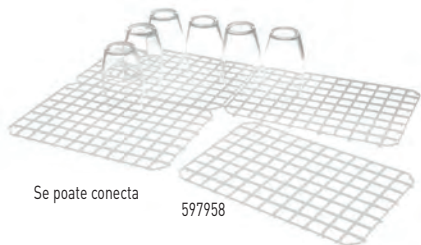

Se poate conecta

597958

**SUPTOR PENTRU SCURGERE PAHARE - 5 BUCATI**

- Se pot prinde intre ele
- Polipropilena alba
- Conforme HACCP



cod	ambalat pe	mm	lei
597958	5	313x209	49,99

BARUP



Vezi filmul



### STORCATOR HIDRAULIC PENTRU CITRICE

- Model cu maneta, placat cu crom
- Aliaj zinc de inalta calitate
- Cu maner pentru stabilitate crescuta
- Maneta se ridica in pozitia initiala cu usurinta cu ajutorul unui arc
- Con presare si container suc din otel inoxidabil

cod	mm	lei
695906	225x180x(H)510	296,99

695906

BAR



NOU



### STORCATOR DE CITRICE

- Multifunctional: pentru lamaie, lime, mandarine si portocale mici.
- Fabricat din otel inoxidabil.
- Manerele mari ofera un grad mare de parghie pentru a apasare usoara.
- Balamaua puternica si durabila nu se rupe usor.
- Diametrul bolului: 75 mm.
- Poate fi spalat in masina de spalat vase.

cod	mm	lei
596470	215x70x(H)55	115,99

NOU



### STORCATOR DE CITRICE

- Fabricat din aliaj de aluminiu gros acoperit cu pulbere.
- Design cu doua boluri (pentru citrice mai mici si mai mari): ø55 mm si ø70 mm.
- Nu poate fi spalat in masina de spalat vase.

cod	mm	lei
592076	225x80x(H)55	79,99

592069

592052

592045



### STORCATOARE MANUALE PENTRU CITRICE

- Aliaj de aluminiu cu strat vopsea

cod	-	mm	lei
592045	verde (pentru lime)	203x60x(H)40	34,99
592052	galben (pentru lamaie)	223x75x(H)45	49,99
592069	oranj (pentru portocale)	232x91x(H)60	59,99



## BLENDERE PENTRU BAR

- Adecvat pentru: mixarea fructelor și legumelor, prepararea cocktailurilor, smoothie-urilor și chiar zdrobirea ghetii.
- Carcasa fabricata din plastic ABS.
- Vas cu o capacitate de 2,5 l, realizat din policarbonat transparent durabil, rezistent la temperaturi cuprinse între -40 și 90 °C.
- Capac realizat din policarbonat.



- Lama detasabila fabricata din otel inoxidabil AISI 420, cu invelis de titan.
- Functie puls.
- Protectie la suprasarcina si supraincalzire.
- Sistem de blocare de siguranta: previne activarea accidentala a aparatului fara vas.



230688



230695



Vezi filmul

Capacul antifonat reduce semnificativ sunetul

Baza anti-alunecare

### BLENDER CU PROTECTIE FONICA PENTRU BAR

- Carcasa pentru izolare fonica este fabricata din policarbonat.
- Reglare manuala, fara trepte a vitezei, cu un buton rotativ.
- Motor cu viteza variabila: 16000 RPM - 24800 RPM (fara incarcatura).
- Caracteristica suplimentara de siguranta: blenderul functioneaza numai atunci cand capacul este complet inchis.

cod	V	W	mm	lei
230688	230	1680	250x300x(H)540	1559,00

### BLENDER DIGITAL PENTRU BAR CU PROTECTIE FONICA

- Carcasa pentru protectie fonica este fabricata din policarbonat.
- Panou de comanda cu ecran tactil digital cu LED.
- 3 trepte de viteza: SCAZUT ca. 8350 RPM, MEDIU ca. 13.500 RPM, RIDICAT ca. 24.800 RPM (fara incarcatura).
- 3 setari cronometru: 30, 45, 90 de secunde.
- Functie suplimentara de siguranta: blenderul functioneaza numai atunci cand capacul este complet inchis.

cod	V	W	mm	lei
230695	230	1680	250x300x(H)546	1649,00

BAR







221105

### STORCATOR CENTRIFUGAL FRUCTE

- Pentru prepararea sucului de fructe si legume tari.
- Cu un recipient mare, de 7 litri, pentru celuloza.
- Foarte puternic, poate procesa pana la 120 kg pe ora.
- Carcasa, cos pentru storcator si disc de taiere din otel inoxidabil.
- Tub de alimentare si impingator din ABS, recipient pentru reziduuri si capac din polipropilena.

- Motorul roteste discul de taiere la 3000 rpm.
- Functionare sigura, functioneaza numai daca capacul si bratul de siguranta sunt blocate la locul lor.
- Foarte usor de demontat si curatat.
- Nu este potrivit pentru gheata sau fructe / legume congelate.

cod	V	W	mm	lei
221105	230	700	246x439x(H)525	2999,00

BAR



**NOU**



Vezi filmul



221228



221204



221099



### STORCATOR DE CITRICE ELECTRIC

- Fabricat din otel inoxidabil AISI 304, aluminiu, PC (polycarbonat).
- 3 conuri de presare incluse in set: mic, mediu, mare (mediul este implicit).
- Se poate opera continuu pana la 10 minute.
- Duza este plasata la inaltimea de 250 mm, oferind posibilitatea de a pune pahare inalte sau o cana direct sub ea.
- Cu protectie la supraincalzire.
- Clasificare impermeabilitate: IPX1.
- NOTA: fara tava de picurare.

cod	V	W	mm	lei
221228	230	180	213x207 x(H)417	999,99



### STORCATOR ELECTRIC CITRICE

- Fabricat din material rezistent la rugina
- Cu bol de stoarcere din otel inoxidabil
- Include 3 conuri interschimbabile din plastic, pentru citrice mici si mari
- Sita ABS
- Viteza 1500 rpm
- Actionat manual prin intermediul unui comutator ON/OFF
- Include capac anti-stropire din polycarbonat
- Toate elementele, exceptand corpul, se pot spala in masina de spalat vase

cod	V	W	mm	lei
221204	230	180	218x307 x(H)466	649,99



### STORCATOR ELECTRIC CITRICE CU PRESA

- Partea superioara cu maneta, cu operare usoara si sigura
- Cuva detasabila si con din otel inoxidabil
- Cu protectie anti stropire
- 980 rpm

cod	V	W	mm	lei
221099	230	230	210x330 x(H)585	1299,00



3 recipiente pentru fructe de diferite dimensiuni



Varf de stoarcere din inox



Manerul cu parghie asigura o operare usoara si sigura

Pret catalog fara TVA

**HENDI**

587





design by  
Robert Bronwasser



Motor puternic cu doua viteze.  
15.000 si 19.000 rpm

2 seturi de  
agitatoare din  
policarbonat  
intocubile (cate  
2 bucati fiecare)



2 pahare: fabricate din  
otel inoxidabil (capacitate:  
0,95 l) si din policarbonat  
(capacitate: 0,9 l)

221631



221600

221617

221624

221631

221648

221655

### MILKSHAKER - DESIGN BY BRONWASSER

- Proiectat de designerul olandez Robert Bronwasser si disponibil in 6 culori atractive.
- Preparati cappuccino Freddo, Frappés si, desigur, milkshake-uri fara efort.
- Carcasa este fabricata din plastic ABS.
- Baza este cantarita pentru o stabilitate suplimentara si este prevazuta cu picioare din cauciuc.
- Motorul poate roti discul agitatorului la doua viteze, 15.000 si 19.000 RPM.
- Controlati milkshaker-ul cu ajutorul unui comutator in doua trepte din partea de sus, care este usor accesibil.
- Agitatorul este prevazut cu un microinterruptor, astfel incat sa poata functiona numai atunci cand cupa este asezata corect.
- Alegeți între două agitatoare diferite pentru a controla nivelul de aerare.
- Setul complet include 2 pahare de amestecare - din otel inoxidabil (0,95 l) si policarbonat (0,9 l) si 2 seturi de agitatoare.
- Cupele si agitatorii sunt sigure pentru masina de spalat vase.

cod	culoare	V	W	mm	lei
221617	Alb	230	400	170x210x(H)485	<b>549,99</b>
221600	Negru	230	400	170x210x(H)485	<b>549,99</b>
221624	Caramel	230	400	170x210x(H)485	<b>549,99</b>
221631	Galben	230	400	170x210x(H)485	<b>549,99</b>
221648	Rosu	230	400	170x210x(H)485	<b>549,99</b>
221655	Albastru	230	400	170x210x(H)485	<b>549,99</b>

BAR



PREPARA  
FREDDO  
CAPPUCCINO,  
FRAPPÉS  
SI MILKSHAKE  
FARA EFORT



221617



221600



221624



961124



961117



961131

### PAHAR DE AMESTECARE DIN POLICARBONAT PENTRU MILKSHAKER - ROBERT BRONWASSER DESIGN

- Fabricat din otel inoxidabil
- Proiectat pentru milkshakerle: 221600, 221617, 221624, 221631, 221648, 221655.
- Potrivit pentru spalare in masina de spalat vase

cod	mm	lei
961124	ø116x(H)161	39,99

### PAHAR DE AMESTECARE DIN OTEL INOXIDABIL PENTRU MILKSHAKE - ROBERT BRONWASSER DESIGN

- Fabricat din otel inoxidabil
- Proiectat pentru milkshakerle: 221600, 221617, 221624, 221631, 221648, 221655.
- Potrivit pentru spalare in masina de spalat vase

cod	mm	lei
961117	ø113x(H)160	64,99

### AGITATOR PENTRU MILKSHAKER - ROBERT BRONWASSER DESIGN

- Fabricat din policarbonat.
- Setul include 2 bucati: un agitator simplu si dublu.
- Creat special pentru milkshakerle: 221600, 221617, 221624, 221631, 221648, 221655, 221495.
- Poate fi spalat in masina de spalat vase.

cod	mm	lei
961131	32x27x(H)50	39,99





271520



### ZDROBITOR GHEATA

- Carcasa din otel inoxidabil si palnie introducere gheata din plastic ABS
- Lame din otel inoxidabil si mecanism rezistent de macinare
- Vas transparent si rezistent cu capacitatea de 12 cupe de gheata macinata
- Macina pana la 12 kg de gheata pe ora
- Nu pentru uz continuu

cod	V	W	mm	lei
271520	230	70	170x290x(H)462	379,99



Vezi filmul

SENZOR DE SIGURANTA  
Aparatul nu porneste  
cu capacul deschis

### INTRERUPATOR ORIZONTAL

Lamele din otel inoxidabil  
fixate pe placi de actionare  
orizontale - procesare  
rapida si eficienta de pana  
la 120 kg/h



DURATA LUNGA DE  
FUNCTIONARE  
A UNITATII DE ACTIONARE  
Racire eficienta cu ajutorul  
unui ventilator performant

271599

AMORTIZOARE  
Acestea elimina vibratiile  
si previn miscarea spontana  
a dispozitivului.

18/8

stainless steel

### ZDROBITOR GHEATA

- Cupa si lame fabricate din otel inoxidabil.
- Carcasa motor fabricata din aluminiu turnat.
- Motor ventilat puternic - poate face fata unei cupe de gheata pline, fara supraincalzire.
- Capac articulata, echipat cu un microintrerupator de siguranta.
- Capacitate cupa: 3 l.
- Grosimea peretelui capsulei: 0,8 mm.
- Viteza cutit: 1000 RPM.
- Zdrobirea unei cupepline de gheata dureaza ≈30 s.
- Iesire: 160 kg/h.
- Clasificare de protectie impotriva apei: IP23.

cod	V	W	mm	lei
271599	230	200	189x344x(H)525	1599,00



## ZDROBITOR GHEATA

- Aliaj de zinc cromat cu lame din otel inoxidabil
- Include lingura gheata din plastic
- Container detasabil

cod	mm	lei
695708	160x140x(H)270	179,99



695708



Vezi filmul



arktic



NOU

- Noua masina Arktik pentru cuburi de gheata tip glont - un echipament extrem de eficient care functioneaza fara racord la apa
- Produce pana la 12kg de gheata in 24h
- Usor de transportat oriunde aveti nevoie
- Intretinere usoara: indicatorii luminosi avertizeaza asupra nivelului apei din bazin
- Racire cu ajutorul unui compresor care functioneaza cu agent de racire R600a
- Fabricat din otel inoxidabil si ABS
- Setul include scafa pentru gheata

## APARAT DE FACUT GHEATA GLAZURATA

- Fabricat din otel inoxidabil si ABS.
- Produce cuburi tip glont
- Racire statica cu un compresor.
- Indicatori pentru nivelul scazut al apei si pentru recipientul plin cu gheata.
- Durata ciclului: ≈ 8-13 min.
- Capacitate recipient gheata: 0,7 kg.
- Capacitate de productie: 12 kg / 24 h.
- Cupa pentru gheata inclusa in set.
- Agent frigorific: R600a .

cod	V	W	mm	lei
271292	230	100	242x358x(H)328	817,99



271292



ABS  
plastic

18/0  
stainless steel



271568



271551



Sunt posibile  
3 dimensiuni de  
cuburi de gheata



Sunt posibile  
3 dimensiuni de  
cuburi de gheata

### MASINA CUBURI GHEATA - 12 KG

- Model de masa
- Corp din otel inoxidabil, capac din ABS negru.
- Productivitate 12 kg/24 ore, stoc de rezerva 3,2 kg - 9 cuburi/ciclu
- Fara racord la retea de apa - lichid de racire R600A
- 3 dimensiuni cuburi gheata, cuburile de gheata se formeaza in jurul tijeii de racire
- Capacitate depozitare 100 cuburi gheata

cod	V	W	mm	lei
271568	230	120	320x400x(H)575	899,99

### MASINA CUBURI GHEATA - KITCHEN LINE 15

- Model de masa
- Carcasa din otel inoxidabil
- Productivitate 15 kg/24 ore, stoc de rezerva de 4,5 kg - 12 cuburi/ciclu
- Fara conexiune fixa apa - lichid de racire R290
- 3 dimensiuni cuburi gheata, cuburile de gheata se formeaza in jurul tijeii de racire
- Capacitate 150 cuburi gheata

cod	V	W	mm	lei
271551	230	130	390x455x(H)699	1249,00

Recipient  
pentru gheata



Cuburi realizate  
prin picurare

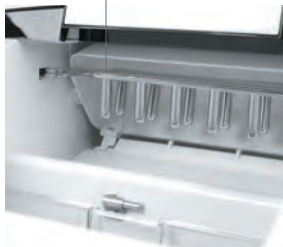

Compressor  
racire (271551)



Comanda electronica

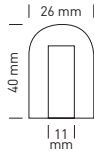

Cuburi de gheata  
in forma de bulb

271773

### MASINA CUBURI DE GHEATA IN FORMA DE GLONT

- Creeaza cuburi de gheata in forma de gloante care sunt partial goale.
- Carcasa complet realizata din otel inoxidabil.
- Poate depozita pana la 7 kg de gheata.
- Furtunurile de admisie si evacuare incluse.
- Clasa climatica: ST.
- Agent de racire: R290.
- Echipat cu LED albastru.

cod	-	V	W	mm	lei
271773	~26 kg/zi	230	241	400x600x(H)675	2629,00
271780	~50 kg/zi	230	293	400x600x(H)675	3069,00



271797



### APARAT DE FACUT FULGI DE GHEATA

- Creeaza fulgi de gheata, ideali pentru cocktail-uri, etc
- Carcasa complet realizata din otel inoxidabil.
- Poate depozita pana la 20 kg de gheata.
- Furtunurile de admisie si evacuare incluse.
- Clasa climatica: ST.
- Agent de racire: R290.
- Echipat cu LED albastru.

cod	-	V	W	mm	lei
271797	~85 kg/zi	230	430	557x650x(H)840	8999,00

Cuburile trebuie  
separate unul  
de celalalt



### MASINA CUBURI DE GHEATA

- Carcasa din otel inoxidabil adecvata pentru instalare sub tejghea
- Poate produce pana la 35 kg de gheata pe zi si poate stoca 15 kg
- Produce 45 de cuburi patrate de gheata intr-un ciclu de 13-16 minute, cuburile trebuie separate unele de celelalte
- Se livreaza cu furtun de alimentare si lingura gheata
- Racire cu sistem de injectie aer, agent racire R290

cod	V	W	mm	lei
271575	230	300	448x400x(H)795	2629,00

271575



## APARAT DE FACUT GHEATA

- Aparatul este conceput pentru a fi utilizat in baruri, pub-uri, cafelele si restaurante.
- Carcasa robusta fabricata din otel inoxidabil AISI 304.
- Interior din plastic.
- Orificiile de aerisire din partea frontala a carcasei pentru a permite instalarea sub blat a aparatului de facut gheata.
- Aparatul utilizeaza metoda de pulverizare pentru a turna perfect cuburile cu orificii hexagonale care are o suprafata de racire mai mare si asigura un timp de racire mai lung, reducand la minimum dilutia bauturilor.



- Performanta si durata de viata extinse ale compresorului.
- Functionare eficienta la o temperatura ambianta de pana la 42°C. Consum redus de energie.
- Reglarea nivelului de umplere a recipientului pentru gheata.
- Picioare reglabile.
- Curatare usoara grazie componentelor detasabile.
- Furtunurile de admisie si evacuare si paleta pentru gheata incluse.

**SISTEM  
HIBRID - CONSUM  
REDUS  
DE ENERGIE**

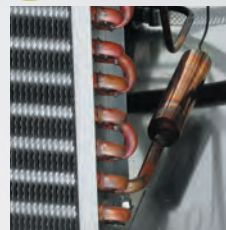

### INTERCOOLING

- metoda inovatoare de transfer a caldurii prin intermediul unui condensator suplimentar
- recuperarea caldurii compresorului utilizata pentru dezghetarea placii de pulverizare.

Cuburi transparente cu forma hexagonala - suprafata mai mare de racire, timp de racire mai mare timp, reducand in acelasi timp diluarea



cod	C-180	C-250 FA	C-400	C-660	C-1200
eficienta	18 kg/24 h	28 kg/24 h	40 kg/24 h	65 kg/24 h	120 kg/24 h
capacitatea buncarului	10-11 kg	12-13 kg	16-18 kg	30-35 kg	45-50 kg
dimensiuni	400x400x(H)650 mm	400x460x(H)670 mm	480x580x(H)750 mm	600x580x(H)820 mm	820x580x(H)940 mm
refrigerant	R134	R454c	R454c	R454c	R454c
putere/tensiune	180 W/230 V	295 W/230 V	455 W/230 V	720 W/230 V	844 W/230 V
greutate	28 kg	32 kg	44 kg	55 kg	83 kg
lei	<b>4299,00</b>	<b>5849,00</b>	<b>5999,00</b>	<b>7509,00</b>	<b>13199,00</b>





271353

#### APARAT PENTRU CUBURI DE GHEATA

- Carcasa fabricata din otel inoxidabil.
- Produce cuburi de gheata transparente care se topesc mai lent decat alte tipuri de gheata.
- Racit cu aer - racire statica asistata de ventilator.
- Indicatori pentru nivelul scazut al apei si pentru recipientul plin cu gheata.
- Functiile de decongelare automata si de curatare automata.
- Capacitate recipient gheata: 6 kg.
- Capacitate de productie: 22 kg/24 h.
- Agent frigorific: R290.

cod	V	W	mm	lei
271353	220	260	380x520x(H)637	4329,00



271360

NOU

#### APARAT PENTRU CUBURI DE GHEATA

- Carcasa fabricata din otel inoxidabil.
- Produce cuburi de gheata transparente care se topesc mai lent decat alte tipuri de gheata.
- Racit cu aer - racire statica asistata de ventilator.
- Indicatori pentru nivelul scazut al apei si pentru recipientul plin cu gheata.
- Functiile de decongelare automata si de curatare automata.
- Capacitate recipient gheata: 42 kg.
- Capacitate de productie: 90 kg/24 h.
- Agent frigorific: R290.

cod	V	W	mm	lei
271360	220	900	730x600x(H)1136	10549,00







209073



### ESPRESSOR AUTOMAT COFFEEMATIC CU ECRAN TACTIL

- Carcasa si unitatea de preparare detasabila sunt fabricate din otel inoxidabil.
- Rasnita plata, ceramica.
- Rezervor de apa cu o capacitate de 4 L care poate fi conectat la un sistem extern de alimentare cu apa.
- 2 palnii de boabe cu capacitate de aproximativ 1,2 kg de boabe de cafea fiecare - posibilitatea de a servi 2 tipuri diferite de cafea (separat).
- Separati dozatorul de apa calda. Sistem de incalzire cu 2 boilere.
- Zona spatiuasa de dozare cu inaltime optima a dozatorului.
- Sistem automat de auto-curatare si clatire.
- Pompe duble.
- Fixati dispozitivul de protectie al interiorului aparatului.
- Panou de comanda tactil de 10 inch. Meniu multilingvistic.
- 30 de programe pentru prepararea diferitelor tipuri de cafea - inclusiv cafea neagra (espresso, ristretto etc.), cafea cu lapte (cappuccino, latte etc.), cafea cu gheata - si, de asemenea, posibilitatea de a turna doar apa fierbinte sau lapte fierbinte.
- Personalizarea suplimentara a fiecarui program: gramajul cafelei, cantitatea de apa, dimensiunea spumei de lapte etc.
- Posibilitatea de conectare la un recipient extern pentru lapte (aflat si intr-un frigider separat pentru lapte).
- Iesire estimata zilnica: pana la 300 de cesti de espresso.
- Presiunea apei: 0,8-6 bari.
- Greutate: 45 kg.

cod	V	W	mm	lei
209073	230	2500-2900	340x540x(H)830	5589,00



209080



### FRIGIDER PENTRU LAPTE CU INCALZITOR PENTRU CESTI

- 2 rafturi incalzite pentru cesti si un cadru din otel inoxidabil AISI 430.
- Recipient pentru lapte de 3,5 l realizat din SAN.
- Usa vitrata cu sticla calita dubla.
- Carcasa frigider fabricata din ABS, cu panouri din sticla calita.
- 4 picioare stabile din aluminiu (H: 60 mm).
- O mica deschidere laterala pentru conectarea directa a unui tub de lapte la fiecare espresso automat.
- Lumina LED in 7 culori.
- 3 comutatoare independente pentru: Lumina LED, frigider, mai calda.
- Agent frigorific: R600A ecologic.
- Racire statica.
- Interval de temperatura: 0-10°C
- Dimensiuni raft: 260x380 mm

cod	V	W	mm	lei
209080	230	168	313x442x(H)613	5589,00





Distribuitor pentru  
ceasca de apa proaspata  
cu capacitate mare. 6 L



Recipient de apa iluminat



Posibilitate de conectare  
la alimentarea cu apa



Vezi filmul

## EXPRESOR CAFEA AUTOMAT - PANOU DE COMANDA TOUCHSCREEN

- Masina de cafea moderna si complet automatizata conceputa pentru cafenele mici, mijlocii, hoteluri, moteluri, camine, stati de distributie a carburantilor, birouri, cantine, unitati de catering si oriunde doriti cafea delicioasa si rapida.
- Datorita unui panou de selectie simplu si usor de citit, masina este ideala pentru autoservire.
- Preparati cafea cu o singura atingere.
- Control digital, ecran mare, tactil de 7 inci.
- Pana la 14 bauturi programabile: espresso, americano, cappuccino, latte, latte macchiato, lapte fierbinte, spuma de lapte, apa fierbinte, espresso dubla, cappuccino dublu, latte dublu, latte macchiato dublu.
- Parametrii fiecaruia dintre programele de bauturi pot fi ajustate individual pentru fiecare client. Parametri ajustabili:
  - taria cafelei de la slaba la foarte puternica, ajustata prin reducerea sau cresterea cantitatii de cafea macinata pe cana de la 8 la 14 g
  - volumul de cafea, prin reducerea sau cresterea cantitatii de apa fierbinte adaugata.
  - temperatura cafelei, prin reglarea temperaturii apei.
  - optiunea „PRE-BREW”, care sporeste suplimentar concentratia si aroma cafelei
  - cantitatea de apa fierbinte pentru prepararea altor bauturi calde, de ex. ceai, ciocolata
  - temperatura apei calde, importanta atunci cand sunt preparate, de ex. ceaiuri verzi care necesita temperaturi mai scazute
  - timpul de distribuire a laptelui fierbinte, de ex. pentru cacao

Recipientul XXL de boabe de cafea poate contine 1 kg

Potrivit si pentru cafea macinata



Capte degresat si functia de reglare a temperaturii laptelui spumat

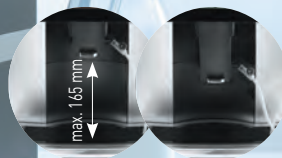

Funcție de reglare a temperaturii apei pentru ceasca de pana la 165 mm in inaltime

208540

- timpul de distribuire a laptelui spumos fierbinte, de ex. pentru a pregati un cappuccino delicios
- Sistemul dublu de incalzire cu doua pompe face posibila distribuirea cafelei preparate si a laptelui fierbinte la doua cesti in mai putin de 50 de secunde, ceea ce faciliteaza un serviciu eficient si rapid.
- Laptele cald si functia de reglare a temperaturii laptelui spumos cald va ofera posibilitatea de a servi chiar si cele mai rafinate bauturi.
- Posibilitatea de a prepara pana la 2 cesti in acelasi timp creste eficienta dispozitivului.
- Dispenser mobil de cafea pentru ceasca de inaltime de pana la 165 mm.

- Containerul mare de 1 kg de boabe de cafea asigura realizarea a peste 140 de esprese fara a se completa.
- Containerul mare de 6 litri de apa dulce face posibila distribuirea a pana la 240 de esprese fara a se completa.
- Masina de cafea poate fi conectata la alimentarea cu apa, ceea ce asigura o functionare continua fara turnarea apei.
- Pompa de vibratii care ofera o presiune de presiune de 19 bar.
- Portbagajul pentru cafea: pana la 35 de portii, in functie de tipul de cafea.
- Rezervor de condens: 2 L.
- Puterea cablului de alimentare: 1,5 m.
- Greutate: 21 kg.

cod	V	W	mm	lei
208540	230	2700	390x511x(H)582	8249,00





reddot design award



Vezi filmul

Panoul de control digital si afisajul fac acest aparat usor de folosit

Recipient boabe cafea 250 g



208984

Panoul de control digital si afisajul fac acest aparat usor de folosit

Recipient boabe cafea 750 g



208953



### ESPRESSO CAFEA AUTOMAT - ONE TOUCH

- Bauturi programabile: espresso, cafea lunga, cappuccino, latte, lapte cald, spuma de lapte, apa fierbinte
- One touch pentru cappuccino si latte macchiato
- Panou digital si afisaj de functii, comenzi si erori
- Rasnita inclusa, cu reglare tip rasnire
- Recipient cafea inclus: 250 g
- De asemenea potrivit pentru cafea macinata
- Rezervor de apa: 1,8 lt
- Tava scurgere
- Dozator de cafea reglabil, 80-140 mm
- Tarie cafea reglabila: 7-14 g / portie
- Volumul reglabil de bautura: 25-240 ml
- Volum reglabil de apa fierbinte 25-450 ml
- Timp abur reglabil: 3-120 s
- Recipientul pentru cafea macinata: 15 portii
- Contor bauturi, individual si total
- Program de curatare automata

cod	V	W	mm	lei
208984	230	1400	302x450x(H)370	3649,00

### ESPRESSO CAFEA AUTOMAT PROFI LINE

- Poate fi programat pentru: espresso, cafea, cappuccino, latte, spuma de lapte, apafierbinte.
- Cappuccino si latte macchiato cu o singura atingere.
- Cu un recipient mare cu zat si deseuri -rezervor de apa.
- Panou de control digital si afisare a functiilor, comenzi si erori.
- Polizor incorporat cu optiuni de polizare reglabile.
- Recipient incorporat boabe de cafea: 750 g.
- Potrivit si pentru cafea macinata.
- Rezervor de apa: 1,8 L (rezervor extern mai mare poate fii conectat).
- Tava de scurgere: 2 L.
- Distribuitor de cafea reglabil cu ambalaj de 80-140 mm.
- Putere de cafea reglabila: 7-14 g/portie.
- Volumul reglabil al bauturii: 25-240 ml.
- Volumul reglabil de apa fierbinte: 25-450 ml.
- Timp de abur reglabil: 3-120 s.
- Recipient pentru zat de cafea: 50 de portii.
- Contor de bauturi individuale si totale.
- Program de curatare automata.

cod	V	W	mm	lei
208953	230	1400	302x450x(H)590	4829,00



## ESPRESSOR DE CAFEA AUTOMAT PROFI LINE XXL

- Bauturi programabile: espresso, cafea lunga, cappuccino, latte, lapte cald, spuma de lapte, apa fierbinte
- Cu recipient mare pentru cafea si rezervor de apa
- Panou digital si afisaj de functii, comenzi si erori
- Rasnita inclusa, cu reglare tip rasnire
- Recipient cafea inclus: 1000 g
- De asemenea potrivit pentru cafea macinata
- Rezervor de apa: 6 lt
- Un rezervor mai mare, extern, poate fi conectat
- Dispenser de cafea reglabil, 100-160 mm
- Tarie cafea reglabila: 7-14 g / portie
- Volumul reglabil de bautura: 15-240 ml
- Volum reglabil de apa fierbinte 25-450 ml
- Timp abur reglabil: 3-120 s
- Contor bauturi, individual si total
- Program de curatare automata

cod	V	W	mm	lei
208991	230	1400	391x506x(H)581	<b>6049,00</b>



Razuiitor incorporat cu  
optiuni reglabile de macinare



## FRIGIDER PENTRU LAPTE

- Aparat electrocasnic compact, economic si eficient pentru racirea si depozitarea laptelui.
- Ideal pentru acasa si birou.
- Raceste pana la 12-15 °C sub temperatura ambianta.
- Deschiderea tubului care conecteaza laptele din frigider cu spuma de lapte integrata intr-un espresso.
- Termostat integrat care previne inghetarea laptelui.
- Frigiderul contine un recipient pentru lapte de 2 litri.
- Dimensiuni camera 163x140x(H)283 mm.
- Capacitate bruta: 6 litri.
- Interior izolat cu poliuretana.
- Nota: puneti numai laptele racit in prealabil in frigider.

cod	V	W	mm	lei
943434	230	50	213x275x(H)343	<b>599,99</b>

## HENDI TOP LINE BY WEGA - ESPRESSOARE PROFESIONALE PROGRAMABILE

- Espressor cu pompa profesionala, realizat din otel inoxidabil cu lacuit de inalta calitate.
- Controlul electronic.
- Programarea a pana la 4 cafele per grup intr-un sistem volumetric.
- Tastatura de selectare a cafelei ergonomica orizontala.
- Duze din spuma izolata cu un manson din cauciuc pentru a proteja impotriva arsurilor.
- Pompa rotativa incastrata.
- Incarcarea automata a boilerului cu apa indicata de un incalzitor de mare temperatura a boilerului.
- Comutator de alimentare cu functie de incalzire simpla.



Vezi filmul



cod	208915	208922	208939	208946
tip	electronic	electronic	electronic	electronic
numarul de grupuri	1	1	2	2
culoare	alb	negru	alb	negru
dimensiuni	530x555x(H)515 mm	530x555x(H)515 mm	740x555x(H)515 mm	740x555x(H)515 mm
numar de duze	1	1	1	1
pentru apa fierbinte	1	1	2	2
numar de duze cu abur	85 mm	85 mm	140 mm	140 mm
inaltimea maxima a cestii	-	-	DA	DA
manometru presiune apa boiler	-	-	DA	DA
manometru de preparare a pompei	2900 W/230 V	2900 W/230 V	3700 W/400 V	3700 W/400 V
putere/tensiune	48 kg	48 kg	62 kg	62 kg
greutate	10999,00	10999,00	13999,00	13999,00
lei				



## ESPRESSOARE PROFESIONALE VERONA

- Masini de espresso profesionale din otel inoxidabil.
- Directie automata (model 207499, 207642), directie semi-automata (model 207598).
- Dozarea manuala a dimensiunii cafelei.
- Umplere automata a apei.
- Spalare automata (model 207499).
- Incalzitor integrat pentru pahare (model 207499).

**VERONA**  
MACCHINE PER CAFFÈ



cod	207598	207642	207499
model	Romeo Easy	Romeo	Julia Compact
tip	semiautomat	automat	automat
numarul de grupuri	1	1	2
dimensiuni	375x530x(H)485 mm	375x530x(H)485 mm	475x563x(H)530 mm
numar de duze pentru apa fierbinte	1	1	1
numar de duze cu abur	1	1	1
capacitatea cazanului	3 l	3	
inaltimea maxima a cestii	80 mm	80 mm	140 mm
functii	Boilerul este umplut automat cu apa Pompa de anti-vibratii incorporata Controlul mecanic al temperaturii apei	Boilerul este umplut automat cu apa Controlul mecanic al temperaturii apei	Usor de utilizat, rezistent la zgarieturi si panouri de control iluminate
putere/tensiune	1800 W/230 V	1800 W/230 V	2700 W/230 V
greutate	30,5 kg	30,5 kg	53 kg
lei	<b>7209,00</b>	<b>8279,00</b>	<b>12299,00</b>





207659



207581

## ESPRESSOR VERONA ROMEO PRO, 1 GRUP, AUTOMAT, CU POMPA ROTATIVA

- Espresso manual mic si elegant, ideal pentru cafelele, baruri, restaurante si companii care apreciaza cafeaua proaspata preparata de inalta calitate.
- Masina complet echipata va permite sa serviti o gama larga de bauturi moderne pe baza de espresso.
- Carcasa compacta din otel inoxidabil gazduieste un boiler de 3 litri.
- Masina dispune de un control mecanic usor de utilizat al temperaturii apei, de o reumplere automata cu apa in boiler si de o pompa de vibratii incorporata.
- Inaltimea maxima a cestii/sticlei: 80 mm.
- Greutate neta: 33,5 kg.

cod	V	W	mm	lei
207659	230	1950	375x530x(H)485	9039,00

## ESPRESSOR VERONA JULIA, 2 GRUPURI, AUTOMAT

- Un espresso manual fiabil si eficient, conceput pentru a face o cafea perfecta.
- Construit cu componente si materiale de inalta calitate pentru a asigura durabilitatea.
- Mecanismul integrat produce o cafea cu gust echilibrat de fiecare data.
- Grupurile individuale pot fi controlate independent cu panouri de comanda iluminate, rezistente la uzura, usor de utilizat.
- Espresso profesional, manual, fabricat din otel inoxidabil.
- Control automat.
- Dozare manuala.
- Reumplere automata cu apa.
- Curatarea automata a grupului.
- Inaltimea maxima a cestii/sticlei: 140 mm.
- Capacitate boiler: 11 L.
- Numarul de grupuri: 2.
- Numar de duze pentru apa clocotita: 1.
- Numar de duze de abur: 2.
- Greutate neta: 59 kg.

cod	V	W	mm	lei
207581	230	3700	665x563x(H)530	13399,00



**RASNITA DE CAFEA ELECTRICA VERONA, CU AFISAJ DIGITAL**

- Destinat tuturor unitatilor care apreciaza timpul, calitatea si precizia in prepararea cafelei ideale.
- Panou tactil sensibil din sticla securizata.
- Recipient mare de boabe pentru pana la 1,65 kg de cafea.
- Cap de slefuire cu lame plate din otel inoxidabil.
- Scoaterea si curatarea usoara a capului permit pastrarea dispozitivului curat.
- Viteza mare de macinare a boabelor - viteza a capului: 1.120 rpm. 4 metode de macinare: standard, automat, folosind o presetare, cu selectare directa.
- Orificiu pentru cafea macinata cu iluminare din spate.
- Inregistrarea automata a cantitatilor de cafea macinata (portiuini).
- Functia anti-electrostatica imbunatateste eficienta macinarii.

cod	V	mm	lei
207451	230	230x400x(H)600	2769,00



207451



Supapa de ventilare dedicata previne aspirarea mirosurilor din exterior si prelungeste durata de valabilitate a cafelei.



992500



**BOABE DE CAFEA LA CREMA 1 KG**

- Amestec atent selectat de boabe Arabica si Robusta de calitate superioara pentru a-i multumi chiar si pe cei mai exigenti iubitori de cafea.
- Aroma intensa cu o usoara aroma de ciocolata.
- Pentru profesionisti.

cod	-	lei
992500	1 kg	69,99



998953

**BISCUITE CU CAMEL LA CREMA**

- 300 de biscuiti per ambalaj.

cod	lei
998953	79,99





208632

**PRE-TAMPER PENTRU PALMA**

- Potrivit pentru majoritatea portafiltrelor.
- Pre-tamper din otel inoxidabil, maner din aluminiu negru.
- Adancimea este reglabila.

cod	mm	lei
208632	ø58x(H)35	<b>98,99</b>



208625

**TAMPER PENTRU CAFEA CU ARC**

- Folosit pentru cafea compacta, potrivit pentru majoritatea portafiltrelor.
- Tamper din otel inoxidabil cu arc.
- Maner din aluminiu negru.

cod	mm	lei
208625	ø58x(H)100	<b>95,99</b>



208731

**PRESA CAFEA**

- Folosita pentru presarea cafelei, potrivita pentru majoritatea aparatelor espresso
- Fabricata din otel inoxidabil
- Maner din lemn vopsit
- Greutate: 380 g

cod	mm	lei
208731	ø58x(H)95	<b>76,99</b>



208670

**SUPORT TAMPER**

- Fabricat din silicon, cu spatiu pentru introducerea unui portafiltru in timpul umplerii.
- Cu o priza pentru plasarea tamperului.

cod	mm	lei
208670	125x140x(H)30	<b>39,99</b>



208649

**SUPORT DUBLU PENTRU TAMPER**

- Fabricat din silicon, cu spatiu pentru introducerea a 2 portafiltre in timpul umplerii.
- Cu doua prize pentru a plasa tamperele.

cod	mm	lei
208649	205x150x(H)45	<b>49,59</b>



208687

**STAND TAMPARE**

- Cu locas pentru introducerea unui portafiltru in timpul presarii.
- Cu o priza pentru plasarea tamperului.

cod	mm	lei
208687	93x142x(H)60	<b>64,99</b>



208724

**PERIE CURATARE**

- Curatare usoara a reziduurilor de cafea din aparatul pentru espresso
- Perie rezistenta din nylon
- Lingurita dozatoare pentru agenti de curatare
- Protectie anti-stropire pentru a mentine manerul uscat
- Set de 2 bucati

cod	mm	lei
208724	(L)225	<b>34,99</b>



208618

**RECIPIENT ROTUND PENTRU ZAT**

- Fabricat din otel inoxidabil.
- Montat cu bara detasabila.

cod	mm	lei
208618	153x185x(H)165	<b>139,99</b>







Vezi filmul

S.S.  
stainless steel

208304

**APARAT CAFEA**

- Placa de incalzire superioara si inferioara, indicatoare luminoase
- Sistem rapid de filtrare cu element de curgere - 1,8 litri in 5 minute
- Temperatura continua de 93 - 96 ° C
- Carcasa si suportul pentru filtre din otel inoxidabil
- Sunt incluse decantoarele de 2 x 1,8 l si filtrele de 25 (90/250)

cod	V	W	mm	lei
208304	230	2100	195x370x(H)598	1219,00

PP  
polipropilena  
S.S.  
stainless steel

208533

**APARAT CAFEA**

- Timp preparare de aprox. 6 minute
- Carcasa din polipropilena cu strat din cauciuc negru
- Vas sticla cu capacitate 1.8 lt, suport filtru si capac din polipropilena
- Cu 2 zone de incalzire ce functioneaza separat
- Cu indicator luminos care semnalizeaza cand este pregatita cafeaua
- Potrivit pentru filtre 110/250

cod	V	W	mm	lei
208533	230	2020	204x400x(H)590	614,99



445907

**CANA APARAT CAFEA**

- Sticla rezistenta cu capac si maner din polipropilena

cod	litri	mm	lei
445907	1.8	ø160x(H)185	64,99

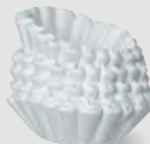
PP  
polipropilena

208656

**FILTRE CAFEA Ø 25 CM - 1000 BUCATI**

- Potrivite pentru aparate de cafea HENDI, Animo si Bravilor
- Diametrul intregului filtru - 250 mm
- Diametrul de jos al filtrului - 110 mm

cod	ambalat pe	mm	lei
208656	1000	ø250x(H)70	169,99



PP 18/8  
polipropilena stainless steel



Indicator interior pentru nivelul maxim al apei



Vezi filmul



209998

### FIERBATOR ELECTRIC - 4.2 LT

- Carcasa si elementul de incalzire din otel inoxidabil
- Maner, capac si baza din polipropilena
- Element de incalzire incorporat, protejat impotriva depunerii de calcar, fapt ce prelungeste durata de viata a incalzitoului si a intregului fierbator
- Indicator luminos ce arata faptul ca incalzitoul este pornit
- Indicator intern de nivel maxim al apei
- Oprire automata dupa fierbere
- Protectie dubla la fierbere uscata
- Potrivit doar pentru fierbere apa, fierberea altui lichid va deteriora produsul

cod	litri	V	W	mm	lei
209998	4.2	230	2000	341x226x(H)305	159,99

PP 18/8  
polipropilena stainless steel



Indicator pentru nivelul apei externe



Vezi filmul



209981

### FIERBATOR ELECTRIC - 1.8 LT

- Carcasa si elementul de incalzire din otel inoxidabil
- Maner, capac si baza din polipropilena
- Ceainicul se poate roti 360 de grade pe baza acestuia
- Element de incalzire ascuns, protejat impotriva depunerii de calcar, fapt ce prelungeste durata de viata a incalzitoului si a intregului fierbator
- Indicator luminos ce arata faptul ca incalzitoul este pornit
- Indicator extern de nivel al apei
- Indicator intern de nivel maxim al apei
- Oprire automata dupa fierbere
- Protectie dubla la fierbere uscata
- Potrivit doar pentru fierbere apa, fierberea altui lichid va deteriora produsul

cod	litri	V	W	mm	lei
209981	1.8	230	2150	226x165x(H)310	94,99



624302

S.S. gas  
stainless steel

### CEAINIC - CU CAPAC

cod	litri	mm	lei
624302	6	ø245x(H)290	149,99



Panou de comanda cu afisaj digital



209936

### FIERBATOR ELECTRIC - 2.5 LT

- Perfect pentru utilizare indelungata si frecventa.
- Cu fierbere rapida.
- Baza separata pentru o manipulare mai usoara a fierbatorului, permitand rotatia completa a fierbatorului la 360°.
- Dotat cu maner ergonomic din polipropilena.
- Cu indicator luminos de incalzire.
- Element de incalzire incorporat, protejat impotriva calcarului.
- Oprire automata cand apa fierbe.
- Cu protectie impotriva fierberii uscate, nu functioneaza fara apa.
- Carcasa si baza din otel inoxidabil AISI 304.
- Greutate: 1,12 kg.

cod	litri	V	W	mm	lei
209936	2.5	230	2150	242x172x(H)294	<b>104,99</b>



209943

### FIERBATOR ELECTRIC FARA FIR CU CONTROL AL TEMPERATURII

- Pentru prepararea bauturilor cu conditii de preparare indicate, cum ar fi ceaiul verde, ceaiul alb sau yerba mate.
- Carcasa si incalzitor din otel inoxidabil AISI304.
- Maner, capac si baza din polipropilena.
- Reglarea si mentinerea temperaturii - apa poate fi incalzita la una dintre aceste temperaturi: 40°C, 60°C, 80°C, 100°C.
- De incalzire incorporat in carcasa, protejat impotriva calcarului.
- Panou de control cu afisaj digital.
- Indicator luminos al termostatului.
- Indicator intern de nivel maxim al apei.
- Functie de oprire automata dupa ce apa a fiert.
- Protectie dubla impotriva pornirii unui ceainic gol.
- Ceainic care poate fi rotit - baza de 360°.
- ATENTIE: destinat numai pentru fierberea apei, fierberea altor lichide poate deteriora ceainicul.

cod	litri	V	W	mm	lei
209943	1.8	230	1800	230x165x(H)255	<b>144,99</b>



425336

**NOU****DOZATOR DE APA**

- Strat exterior realizat din otel inoxidabil AISI 410, strat interior realizat din otel inoxidabil AISI 304, cu izolatie PU (spuma poliuretanică).
- Adecvat atat pentru apa calda, cat si pentru cea rece.
- Rezistent la temperatura in intervalul -10 - 100°C.
- 1 duza cu robinet pentru o turnare convenabila.
- Capacitate: 10 l.
- NOTA: pentru bauturi reci, cuburile de gheata trebuie puse foarte incet in recipient.

cod	litri	mm	lei
425336	10	ø226x(H)360	209,99

240700

**BOILER PENTRU BAUTURI FIERBINTI - 25 LT**

- Fierbator din otel inoxidabil.
- Montat cu manere izolate din polipropilena si robinet fara picurare.
- Termostat reglabil pana la 110 ° C.
- Ideal pentru vin fiert sau apa fierbinte.
- Timp necesar pentru fierbere ≈ 75 min.
- Nu este potrivit pentru laptele de ciocolata.

cod	litri	V	W	mm	lei
240700	25	230	2500	442x426x(H)491	549,99

240601

**BOILER PENTRU BAUTURI FIERBINTI - 25 LT**

- Fierbator din otel inoxidabil vopsit.
- Montat cu manere izolate din polipropilena si robinet fara picurare.
- Termostat reglabil pana la 110 ° C.
- Ideal pentru vin fiert sau apa fierbinte.
- Timp necesar pentru fierbere ≈ 75 min.
- Nu este potrivit pentru laptele de ciocolata.

cod	litri	V	W	mm	lei
240601	25	230	2500	435x441x(H)500	499,99

## DISTRIBUITOR AUTOMAT DE BAUTURI CALDE

- Fabricat din oțel inoxidabil periat, cu capac și maneră din polipropilenă.
- Designul cu pereți dubli al ceainicului crește puterea căldurii și izolarea.
- Când este conectat la sursa de apă, dispozitivul se umple întotdeauna automat.
- Echipat cu doi senzori de nivel al apei.
- Panou de control cu afișaj digital și lumini de control pentru încălzire și tineră cald.
- Temperatura poate fi setată de la 30 la 100°C.
- Cu funcție de menținere la cald, oprire automată și senzor de protecție la depășire.



- Robinetul fără picurare este din oțel inoxidabil, are un maner cool-touch și este poziționat la un nivel mai înalt pentru a putea așeza sub acesta recipientul mai mare.
- Capacul este echipat cu un blocare prin răsucire și un maner cu atingere rece.
- Cu tava de picurare detașabilă.
- Disponibil în două dimensiuni: 240717 pentru 8,5-23 litri/oră, 240724 pentru 17,5-33 litri/oră.



240717



240724

cod	litri	V	W	mm	lei
240717	8.5	230	2000	277x363x(H)505	<b>1399,00</b>
240724	17.5	230	2600	405x330x(H)600	<b>1549,00</b>

Conectarea la sursa de alimentare cu apă



Panou de comandă cu afișaj digital



Robinetul este fabricat din oțel inoxidabil cu un maner ușor de atins



## BOILER PENTRU BAUTURI CALDE CU PERETI DUBLI



- Ideal pentru vin fierț și apa fierbinte pentru ceai.
- Funcționează automat și păstrează băuturile la temperatura de servire.
- Pierderile de căldură și consumul de energie sunt reduse de carcasa izolată din oțel inoxidabil lustruit cu pereți dubli.
- Capac cu sistem de siguranță „twist-lock”.
- Element de încălzire protejat la scara sub rezervor cu protecție la supraîncălzire.
- Prevăzută cu manere care nu se încălzesc, maner de acoperire și duză anti-picurare, toate confecționate din polipropilenă.
- Curățați indicatorul de nivel în litri.
- Înălțimea maximă a cestii: 130 mm (fără tavă de picurare).
- Cu comutator de alimentare și indicatoare luminoase pentru încălzire și depanare.
- Temperatura poate fi setată de la 30°C la 100°C.
- Tava de picurare inclusă.
- Se prepară ± 60 de cani în 40 min.
- Nu este potrivit pentru laptele cu ciocolată.

PANA LA  
**20%**  
ECONOMIE  
DE ENERGIE



Vezi filmul

Tava de scurgere  
inclusă



211168



211175

cod	capacitate (l)	V	W	mm	tiimp de fierbere (min)	lei
211168	9	230	1300	310x330x(H)490	40 ±5	<b>429,99</b>
211175	18	230	2250	360x380x(H)598	37 ±5	<b>518,99</b>

EXPRESOARE SI ACCESORII



Cu pereți dubli - consum de energie mai mic cu până la 20%



Element de încălzire fără întreținere sub rezervor



Capac cu sistem de siguranță cu blocare cu rasucire, prevăzută cu maneră din polipropilenă cu atingere rece



## BOILER PENTRU BAUTURI CALDE CU UN SINGUR PERETE



- Ideal pentru vin fierț și apa fierbinte pentru ceai.
- Funcționează automat și păstrează băuturile la temperatura de servire.
- Carcasa și capac din oțel inoxidabil cu un singur perete cu sistem sigur de blocare prin răsucire.
- Element de încălzire protejat la scara sub rezervor cu protecție la supraîncălzire.
- Prevăzută cu maneră care nu se încălzește, capac cu maneră și duza anti-picurare, toate confecționate din polipropilena.
- Curățați indicatorul nivelului apei în litri.
- Înălțimea maximă a cestii: 130 mm (fără tavă de picurare).
- Cu un comutator de alimentare și indicatoare luminoase pentru încălzire și depanare.
- Temperatura poate fi setată între 30° și 100°C.
- Pregătește ± 65 de cesti în 40 de minute.
- Nu este potrivit pentru laptele de ciocolată.



Vezi filmul



211137



211144



211151

cod	capacitate (l)	V	W	mm	țimp de fierbere (min)	lei
211137	10	230	1300	340x315x(H)430	40 ± 5	<b>335,99</b>
211144	20	230	2250	415x382x(H)480	42 ± 5	<b>458,99</b>
211151	30	230	2600	415x382x(H)620	65 ± 2	<b>639,99</b>
211298	tava picurare					<b>35,09</b>



Tava pentru stropire - se va comanda separat

211298

Indicator interior pentru nivelul maxim al apei



Cu robinet de blocare



Capac cu sistem de siguranță cu blocare cu răsucire, prevăzută cu maneră din polipropilena cu atingere rece



## BOILERE BY ROBERT BRONWASSER



- Concepute de renumitul designer olandez Robert Bronwasser.
- Designul unic si atentia la detalii scot in evidenta aceste echipamente.
- Disponibile in 2 versiuni: otel inoxidabil argintiu sau negru cu finisaj mat
- Manere elegante fabricate din polipropilena
- Robinet anti picurare
- Indicator nivel apa din sticla

- Tava picurare cu magnet, usor de curatat
- Indicator termostat
- Gradatie nivel maxim de apa, localizata in interiorul vasului.
- Buton de reset - in caz de supraincalzire
- Avertizor luminos pentru supraincalzire si decalcifiere
- Numai pentru fierberea apei sau incalzirea vinului - nu este potrivit pentru alte lichide precum laptele sau ciocolata calda



211410

### BOILER PENTRU BAUTURI CALDE - BY ROBERT BRONWASSER

- Carcasa fabricata din otel inoxidabil satinat.

cod	capacitate (l)	V	W	mm	temp de fierbere (min)	lei
211410	9	230	950	303x360 x(H)450	58	369,99
211427	16	230	1650	352x397 x(H)500	63	449,99



211458

### BOILERUL DE BAUTURI CALDE NEGRU MAT - BY ROBERT BRONWASSER

- Carcasa fabricata din otel inoxidabil, neagra, cu finisaj mat.

cod	capacitate (l)	V	W	mm	temp de fierbere (min)	lei
211458	9	230	950	309x333 x(H)450	58	459,99
211465	16	230	1650	356x400 x(H)510	63	549,99



Design unic cu robinet anti-picurare, cu sticla gradata integrata



Tava de picurare este magnetica



Boilerul pastreaza bautura la temperatura de servire dupa incalzire



## PERCOLATOARE CAFEA BY ROBERT BRONWASSER

- Concepute de renumitul designer olandez Robert Bronwasser.
- Designul unic si atentia la detalii scot in evidenta aceste echipamente.
- Disponibile in 2 versiuni: otel inoxidabil argintiu sau negru cu finisaj mat
- Manere elegante fabricate din polipropilena
- Robinet anti picurare
- Indicator nivel apa din sticla



- Tava picurare cu magnet, usor de curatat
- Indicator nivel lichid fabricat din sticla
- Cos de filtrare a zaturii
- Indicator luminos pentru supraincalzire si decalcifiere
- Indicator luminos la la atingerea temperaturii optime
- Inaltimea maxima a cestii: 100mm
- Percolatoarele retin caldura automat dupa fierberea lichidului



211434



211472

### PERCOLATOR - BY ROBERT BRONWASSER

- Carcasa fabricata din otel inoxidabil satinat.

cod	capacitate (l)	V	W	mm	timp de fierbere (min)	lei
211434	7	230	1050	303x353 x(H)450	57	<b>349,99</b>
211441	14	230	1750	354x418 x(H)500	52	<b>429,99</b>

Design unic cu robinet anti-picurare, cu sticla gradata integrata



Tava de picurare este magnetica



Cos de filtrare



### PERCOLATOR NEGRU MAT - BY ROBERT BRONWASSER

- Carcasa fabricata din otel inoxidabil, neagra, cu finisaj mat.

cod	capacitate (l)	V	W	mm	timp de fierbere (min)	lei
211472	7	230	1050	305x350 x(H)451	52	<b>499,99</b>
211489	14	230	1750	352x420 x(H)500	57	<b>549,99</b>



## PERCOLATOR

- Corp cu un singur perete din otel inoxidabil
- Cuva de filtrare are un filtru incorporat pentru cafeaua macinata grosier, filtrul din hartie nu mai este necesar
- Percolatorul pastreaza cafeaua la temperatura de servire dupa incheierea procesului de preparare



208007

## PERCOLATOR

- Corp cu un singur perete din otel inoxidabil
- Cuva de filtrare are un filtru incorporat pentru cafeaua macinata grosier, filtrul din hartie nu mai este necesar
- Percolatorul pastreaza cafeaua la temperatura de servire dupa incheierea procesului de preparare
- Cu sticla gradata, robinet anti-picurare si functie de resetare automata
- Indicatorul luminos semnalizeaza incheierea procesului de preparare si daca este necesara decalcifierea

cod	litri	V	W	mm	lei
208007	6	230	1500	355x355x(H)470	<b>419,99</b>
208106	10	230	1500	406x390x(H)522	<b>579,99</b>
208205	16	230	1500	407x382x(H)595	<b>629,99</b>

S.S.  
stainless steel

- Cu sticla gradata, robinet anti-picurare si functie de resetare automata
- Indicatorul luminos semnalizeaza incheierea procesului de preparare si daca este necesara decalcifierea



209882

## BOILER BAUTURI CALDE

- Cu un singur perete
- Ideal pentru vin fierdt si apa fiarta pentru ceai
- Timp de fierbere aprox. 50 min
- Temperatura maxima 94-99°C
- Protectie impotriva fierberii uscate
- Nu se poate folosi pentru ciocolata calda

cod	litri	V	W	mm	lei
209899	18	230	2200	385x385x(H)595	<b>529,99</b>
209882	9	230	2200	370x332x(H)472	<b>359,99</b>



## PERCOLATOR CU PERETI DUBLI

- Structura peretilor dubli, stefuiti, izolati, din otel inoxidabil, reduce pierderile de caldura prin conductie, convecție și radiatie.
- Consum de energie cu pana la 20% mai mic fata de cele cu un singur perete.
- Carcasa și rezervorul din otel inoxidabil.

- Manere sudate din otel inoxidabil cu mansoa de silicon.
- Robinet anti-picurare.
- Vizor.
- Indicator decalcifiere.
- Tava picurare cu grilaj din otel inoxidabil.



211205



211403

## PERCOLATOR CU PERETI DUBLI

cod	litri	V	W	mm	lei
211106	6	230	1500	316x350x(H)480	<b>499,99</b>
211205	10	230	1500	370x390x(H)525	<b>699,99</b>
211304	16	230	1500	360x401x(H)647	<b>759,99</b>

## PERCOLATOR CU PERETI DUBLI

- Termostat de temperatura, ajustabila pana la 110°C
- A nu se folosi pentru ciocolata calda

cod	litri	V	W	mm	lei
211403	9	230	2200	322x390x(H)522	<b>449,99</b>
211502	18	230	2200	386x393x(H)666	<b>599,99</b>



## PERCOLATOARE CU PERETI DUBLI

- Filtru interior pentru cafea macinata grosier din otel inoxidabil, nu este necesara utilizarea filtrelor.
- Carcasa izolata dubla reduce costul energiei si impiedica racirea rapida.
- Capac cu sistem de siguranta „Twist-lock”.
- Prevazut cu manere cool-touch, maner de acoperire si gura anti-picurare, toate din polipropilena.
- Indicator clar de nivel in litri, cu indicarea numarului de cesti ramase.
- Inaltime maxima cupa: 110 mm.
- Atinge pana la 90°C in timpul prepararii cafelei, mentine apoi temperatura la 70°C ( $\pm 5^\circ\text{C}$ ).
- Cu intrerupator de alimentare protejat cu silicon si lumini indicatoare pentru incalzire si mentinerea calda.
- Element de incalzire protejat impotriva calmului sub rezervor cu protectie impotriva supraincalzirii.
- Tava de scurgere inclusa.



PANA LA  
**20%**  
ECONOMIE  
DE ENERGIE



SISTEM INOVATOR  
DE PREPARARE  
apa curge incet pe  
liniile de picurare,  
ceea ce imbunatatesta  
si aroma cafelei



211366

cod	capacitate (l)	V	W	mm	temp de fierbere (min)	diametru filtru (mm)	lei
211366	13	230	1650	360x380x(H)532	37 $\pm$ 5	$\varnothing$ 254	919,99



Cu pereti dubli - consum de energie mai mic de pana la 20%



Filtru incorporat pentru cafea macinata grosier



Capac filtru cu orificii



Tava de scurgere usor demontabila



Vezi filmul



## DISPENSER CIOCOLATA FIERBINTE

- Sistemul de incalzire bain-marie previne lipirea ciocolatei de partea inferioara a vasului
- Partea de jos a recipientului este construita din otel inoxidabil
- Pereti din policarbonat
- Tava scurgere cu indicator de avertizare cand este plina
- Protectie supraincalzire
- Amestecarea continua garanteaza o consistenta omogena ciocolatei
- Robinet special anti-picurare
- Interval temperatura: de la 65° pana la 85°C
- Temperatura ambientala necesara: de la 10°C pana la 32°C

cod	litri	V	W	mm	lei
274125	5	230	1006	440x360x(H)471	<b>2049,00</b>
274149	10	230	1006	415x300x(H)580	<b>2299,00</b>

Sistemul de incalzire  
Bain-Marie previne  
arderea ciocolatei calde



274149

274125



797938

797945

## CEASCA SI FARFURIE PENTRU CAFEA SI CAPPUCINO

- Vandut numai la set

code	-	packed per	litry	mm	lei
797938	ceasca	6	0.185		<b>139,99</b>
797945	farfurie	6		ø150	<b>74,99</b>



797952

797969

## CEASCA SI FARFURIE PENTRU ESPRESSO

- Comercializat numai la set

code	-	packed per	mm	lei
797952	ceasca	6		<b>69,99</b>
797969	farfurie	6	ø110	<b>44,99</b>





15x GN 1/1

15x 600x400



7x GN 1/1

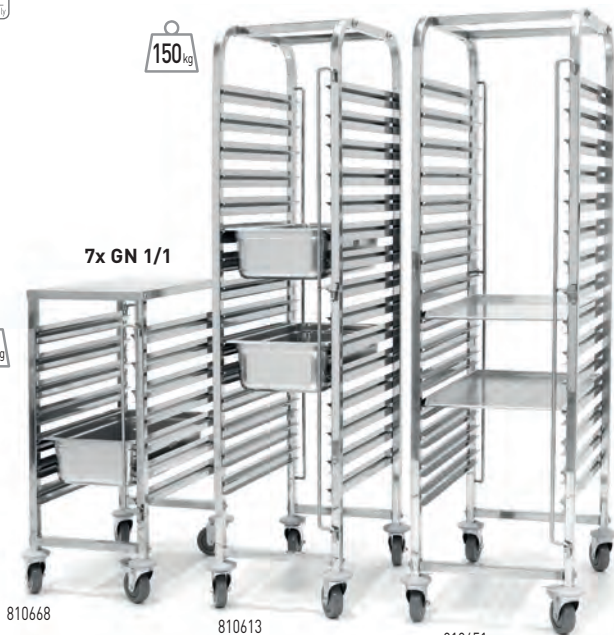

810668

810613

810651



Doua  
cu frane



Echipat cu  
un sistem  
simplu de  
blocare



THERMOBOX, RAFTURI, CARUCIOARE

### CARUCIOR DEBARASARE TAVI 7 X GN 1/1

- Pentru tavi servite GN 1/1 - spatiu intre niveluri 80 mm.
- Cu masa de lucru
- Tavile se blocheaza in ambele parti
- Echipat cu 4 roti dintre care 2 dotate cu frana
- Se livreaza demontat

cod	mm	lei
810668	445x615x(H)945	749,99

### CARUCIOR COMPACT DEBARASARE TAVI 15 X GN 1/1

- GN 1/1 cu 15 niveluri - spatiu intre niveluri 80 mm
- Tavile se blocheaza in ambele parti
- Echipat cu 4 roti dintre care 2 dotate cu frana
- Se livreaza demontat

cod	mm	lei
810613	440x610x(H)1710	849,99

### CARUCIOR DEBARASARE TAVI 15 X 600X400 MM

- 600x400 mm cu 15 niveluri - spatiu intre niveluri 80 mm
- Tavile se blocheaza in ambele parti
- Echipat cu 4 roti dintre care 2 dotate cu frana
- Se livreaza demontat

cod	mm	lei
810651	515x680x(H)1710	899,99

15x GN 1/1

15x 600x400



813270



813287

### CARUCIOR KITCHEN LINE PENTRU 15 TAVI GN 1/1

- Destinat utilizării în restaurante, hoteluri, baruri fast-food, precum și în companii de catering sau firme pentru evenimente
- O construcție solidă, ușor de asamblat, realizată din oțel inoxidabil AISI 201, ușor de curățat
- Sistemul de ghidaje de profil permite transportul diferitelor configurații de containere GN 1/1, GN 1/2, GN 1/3 în același timp
- Capacitatea maximă a unui anumit tip de containere: 15x GN 1/1, 30x GN 1/2, 45x GN 1/3
- Protecție împotriva alunecării de ghidaje la capetele ghidajelor
- 80 mm distanță între ghidaje pentru o încărcare optimă a caruciorului
- 4 roți din cauciuc Ø 100 mm (inclusiv 2 cu frâne) absorb vibrațiile și asigură manevrarea ușoară și sigură a caruciorului
- 4 bare de protecție din cauciuc pentru a proteja împotriva impacturilor accidentale asupra mobilierului sau peretilor
- Sarcina admisibilă a caruciorului cu o greutate distribuită uniform de 100 kg

cod	mm	lei
813270	380x550x(H)1705	769,99

### CARUCIOR KITCHEN LINE PENTRU 15 TAVI 600X400

- Destinat utilizării în brutării, precum și în restaurante, hoteluri, baruri de fast-food sau companii de catering sau firme de evenimente
- O construcție solidă, ușor de asamblat, realizată din oțel inoxidabil AISI 201, ușor de curățat
- Sistemul de ghidaje profilate va permite să transportați 15 tavi cu dimensiuni 600x400 mm în același timp
- Protecție împotriva alunecării de pe foi la capetele ghidajelor
- 80 mm distanță între ghidaje pentru o încărcare optimă a caruciorului
- 4 roți din cauciuc Ø 100 mm (inclusiv 2 cu frâne) absorb vibrațiile și asigură manevrarea ușoară și sigură a caruciorului
- 4 bare de protecție din cauciuc pentru a proteja împotriva impacturilor accidentale asupra mobilierului sau peretilor
- Sarcina admisibilă a caruciorului cu o greutate distribuită uniform de 100 kg

cod	mm	lei
813287	470x620x(H)1735	899,99



150kg

30x GN 1/1



810576

**CARUCIOR MOBIL DUBLU - 30 X GN 1/1**

- GN 1/1 cu 30 perechi de ghidaje - spatiul dintre acestea este de 80 mm.
- Blocaje tavi pe ambele parti.
- Echipat cu patru roti, dintre care doua au frane.
- Livrare in ambalaj plat.
- Sarcina maxima este de 150 kg. cand sarcina este distribuita uniform.

cod	mm	lei
810576	740x550x(H)1730	1299,00



150kg

15x GN 1/1



810606



Pentru a economisi spatiu in timpul depozitarii, carucioarele pot fi impinse unul in celalalt

**CARUCIOR COMPACT DEBARASARE TAVI 15 X GN 1/1**

- Pentru a economisi spatiu in timpul depozitarii carucioarele pot fi imbinat
- GN 1/1 cu 15 niveluri - spatiu intre niveluri 80 mm
- Blocare tavi in ambele parti
- Echipat cu 4 roti dintre care 2 dotate cu frana
- Se livreaza demontat
- Sarcina maxima este de 150 kg. cand sarcina este distribuita uniform.

cod	mm	lei
810606	445x610x(H)1710	797,99



### CARUCIOR MOBIL DUBLU - 12 X GN 1/1

- GN 1/1 cu 12 rafturi - spatiul dintre acestea este de 80 mm
- Blocaje tavi pe ambele parti
- Echipat cu patru roti, dintre care doua au frane
- Se livreaza demontat

cod	mm	lei
810569	740x550x(H)940	879,99



810569

**MODEL NOU**

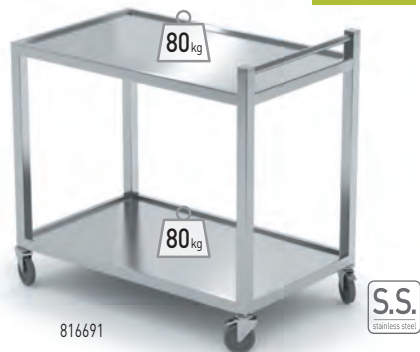

816691

**MODEL NOU**

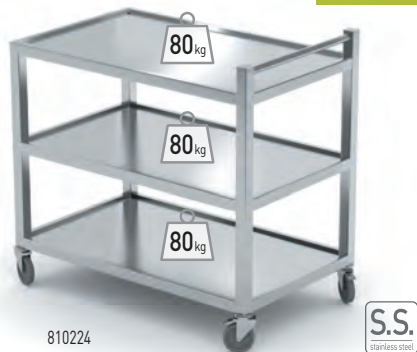

810224

### CARUCIOR CU 2 RAFTURI, SUDAT.

- Fabricat din otel inoxidabil AISI 430.
- Sudate pentru durabilitate si stabilitate ridicate. 2 rafturi H=10 mm imprimate in relief pentru a proteja vasele impotriva caderii.
- Dimensiunile totale ale raftului: 700x500 mm.
- Dimensiunile raftului fara imprimare in relief: 650x450 mm.
- Distaanta dintre rafturi: aprox. 600 mm.
- Incarcatura maxima per raft (cu conditia ca incarcatura sa fie distribuita uniform): 50 kg.
- Maner orizontal din otel inoxidabil cu proiectie de 100 mm.
- 4 rotite pivotante de  $\varnothing 100$  mm cu bare de protectie, dintre care doua cu frane.

cod	mm	lei
816691	800x500x(H)850	1249,00

### CARUCIOR DE SERVIRE HEAVY DUTY

- Fabricat din otel inoxidabil, ranforsat pentru rezistenta mai mare.
- Cu 3 rafturi.
- Incarcare maxima pe raft 80 kg.
- Cu 4 rotii, din care 2 cu frana.

cod	mm	lei
810224	800x500x(H)850	1499,00





810101

### CARUCIOR SERVIRE CU 3 RAFTURI

- Fabricat din otel inoxidabil
- Echipat cu 3 rafturi si material cu izolare fonica dedesubt
- Sarcina maxima pe raft este de 50 kg
- Include 4 roti pivotante din care doua cu frane, rotile sunt echipate cu protectie colt
- Distanța între rafturi este de 270 mm
- Se livreaza demontat

cod	mm	lei
810101	905x585x(H)945	549,99



811320

### CARUCIOR DE SERVIRE NEGRU MAT.

- Fabricat din otel inoxidabil cu un finisaj negru mat
- 3 rafturi captusite cu material fonoabsorbant in partea de jos
- Sarcina uniforma la raft: 50 kg
- Echipat cu 4 roti pivotante cu bare de protectie, 2 cu frane
- Margini rotunjite
- Distanța dintre rafturi: 270 mm

cod	mm	lei
811320	905x585x(H)945	679,99



810002



### CARUCIOR SERVIRE CU 2 RAFTURI

- Fabricat din otel inoxidabil
- Echipat cu doua rafturi si material cu izolare fonica dedesubt
- Sarcina maxima pe raft este de 50 kg
- Include 4 roti pivotante din care doua cu frane, rotile sunt echipate cu protectie colt
- Distanța între rafturi este de 550 mm
- Se livreaza demontat

cod	mm	lei
810002	905x585x(H)945	379,99





810118

### CARUCIOR SERVIRE CU 4 RAFTURI

- Fabricat din otel inoxidabil
- Echipat cu 4 rafturi
- Include 4 roti pivotante din care doua cu frane, roțile sunt echipate cu protectie colt
- Se livreaza demontat



810125

### CARUCIOR SERVIRE CU 5 RAFTURI

- Fabricat din otel inoxidabil
- Echipat cu 5 rafturi
- Include 4 roti pivotante din care doua cu frane, roțile sunt echipate cu protectie colt
- Se livreaza demontat

cod	mm	lei
810118	905x585x(H)1245	699,99

cod	mm	lei
810125	905x585x(H)1545	999,99



### CARUCIOR SERVIRE DIN POLIPROPILENA

- Fabricat din polipropilena
- Echipat cu 3 rafturi
- Sarcina maxima pe raft este de 50 kg
- Include 4 roti pivotante din care doua cu frane, roțile sunt echipate cu protectie colt
- Distanța între rafturi este de 340 mm
- Se livreaza demontat

cod	mm	lei
810200	800x410x(H)950	399,99



810200





MAX.  
98 l



AMER★BOX



877920



cupa



capac  
transparent



patru roti  
de cauciuc

### CARUCIOR PENTRU INGREDIENTE

- Folositor in orice bucatarie pentru depozitare, transport sau masurare rapida a cantitatilor de alimente, cum ar fi: faina, zahar, sare, cereale, orez
- Recipientul poate fi incarcat cu 103 kg zahar sau 68 kg faina
- Structura din polietilena, solida, dintr-o singura bucata
- Colturi rotunjite, pereti interiori netezi, pentru o curatare usoara
- Ghidaje in partea superioara, la interior, pentru scafa
- Capac din polipropilena transparenta, pentru identificare usoara a continutului si cantitatii
- Patru roti laterale de cauciuc,  $\varnothing 75$  mm, doua fiind dotate cu frane cu frane pentru o transportare mai usoara.
- Inaltimea ergonomica de 71 cm este ideala pentru a fi pusa sub o masa de lucru.

cod	litri	mm	lei
877913	81	333x743x(H)711	799,99
877920	98	394x755x(H)735	849,99

MAX.  
110 l



877883



tava de scurgere



2 roti cu frane



scurgere



cupa

### CONTAINER IZOLAT PENTRU GHEATA - 110 LT

- Ideal pentru transportul cuburilor sau a fulgilor de gheata, pe distante lungi
- Carcasa robusta din polietilena, rezistenta la socuri si impact
- Izolatie groasa din spuma, pentru a mentine temperatura ghetii cat mai mult posibil
- Pereti interiori rezistenti la zgarieturi si pete
- Capac etans, gisant, care permite acces usor la gheata
- Maner ergonomic integrat cu carcasa
- Doua roti mari rezistente la terenul neuniform si doua roti pivotante mai mici, cu frana
- Drenaj profilat pentru gheata topita, cu robinet
- Livrat gata de utilizare, nu necesita asamblare
- 4 roti, 2 cu frane ( $\varnothing 20$  mm mare, mic  $\varnothing 10$  mm)
- Robinet, scafa si tava scurgere incluse

cod	litri	mm	lei
877883	110	585x800x(H)745	2219,00



### CARUCIOR FARFURI

- Asigura transportul veselei in siguranta
- Dispozitivele mobile de protectie din polietilena fac posibila incarcarea farfuriilor de diferite dimensiuni
- Designul extrem de robust din polietilena protejeaza vesela de ciobire sau spargere
- Numarul de stive de farfurii: 6
- Numarul de farfurii pe stiva: 50
- Roti rezistente la sol neuniform, fara marcare chiar la sarcina maxima
- Doua roti pivotante cu frane, ø10 mm, roti mari ø20 mm
- Rezistent la socuri si la impact
- Capac din vinil, pentru a indeplini standardele sanitare stricte, inclus
- Pentru farfurii cu diametrul de la ø115 mm la ø330 mm

LDPE  
polyethylene



cod	mm	lei
877906	930x720x(H)785	2699,00



Include o husa de vinil cu fiecare cos pentru depozitare igienica

pana la 50 de farfurii intr-o singura stiva

roti fata cu frane

### Exemplu de seturi



4 coloane - farfurii  
ø230-335 mm



6 coloane - farfurii  
ø118-230 mm



4 coloane - farfurii  
ø115 mm  
2 coloane - farfurii  
ø140 mm  
2 coloane - farfurii  
ø230 mm



5 coloane - farfurii  
ø128 mm  
2 coloane - farfurii  
ø231 mm





Orificiu de aerisire



Usa cu garnitura



**AMER★BOX**



877814



877821



2 rotoare de torsiune cu frane

### CONTAINER TERMIC CATERING 2 X GN 1/1 200

- Izolat cu pereti dubli din polietilena LDPE - polietilena dura rezistenta la impact
- Pastreaza fierbinte si rece
- Cu 2 manere robuste pentru transport
- Ghidaje formate prin presare, montate in carcasa camerei
- Dimensiuni interioare: 335x533x(H)590 mm
- Potrivit pentru tavi Gastronorm 1/1:
  - Tava gastronomică H 10 mm: 12 bucati
  - Tava gastronomică H 65 mm: 6 bucati
  - Tava gastronomică H 100 mm: 4 bucati
  - Tava gastronomică H 150 mm: 3 bucati
  - Tava gastronomică H 200 mm: 2 bucati

cod	mm int.	mm	lei
877814	335x533 x(H)590	477x680 x(H)620	1449,00

#### Mentineria temperaturii

fierbinte

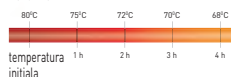

rece

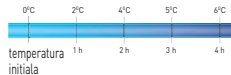

#### Exemplu de seturi

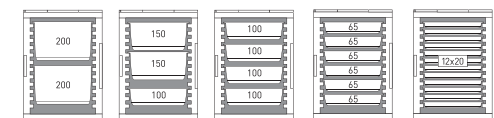

Stivuibil

### CARUCIOR PENTRU CONTAINER TERMIC

cod	mm	lei
877821	530x710x(H)230	579,99

## DISTRIBUITOR DE BAUTURI IZOLAT CU ROBINET

- Ideal pentru depozitarea, transportul și servirea bauturilor calde și reci
- Carcasa robusta din polietilena LDPE
- Izolatie din spuma poliuretanică
- 4 cleme rezistente, de 25 mm latime pentru deschidere/ inchidere usoara și rapida
- Manere de transport confortabile
- Distanța robinet fata de podea: 95 mm
- Robinet incastrat - protecție împotriva deteriorării în timpul transportului
- Livrat cu autocolante pentru identificarea rapida a bauturilor
- Aerisire pentru deschiderea usoara a capacului
- Rezistent la socuri și la impact
- Camera rotunjita cu caneluri care conduc la robinet

cod	litri	mm	lei
877869	9.4	230x420x(H)470	554,99
877876	18	230x420x(H)620	709,99

**AMER★BOX**



4 zavoare

fixare pentru abtibil



877869

Mentineria temperaturii

fierbinte

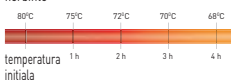

rece

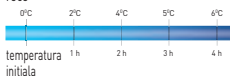

## CONTAINER IZOLAT CATERING GN 1/1, INCARCARE FRONTALA

- Construcție din polietilena HDPE
- Pereti dubli, cu strat interior din spuma poliuretanică de calitate înaltă, asigură o izolare perfectă și pastrare îndelungată a temperaturii alimentelor
- Capac etans cu 4 cleme din nailon rezistent

cod	mm int.	mm	lei
877852	530x325x(H)200	630x460x(H)305	749,99

Mentineria temperaturii

fierbinte

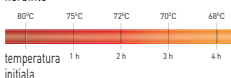

rece

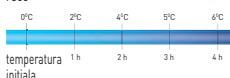

### Exemplu de seturi



1x GN 1/1

2x GN 1/2

2x GN 1/4  
1x GN 1/2

1x GN 2/3  
1x GN 1/3

3x GN 1/3

4x GN 1/4

2x GN 1/6  
2x GN 1/3

6x GN 1/6

Pret catalog fara TVA

**HENDI**

631

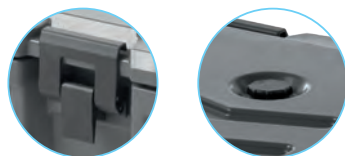

4 zavoare

cupa de aerisire



możliwość  
piętrowania



## CUTII TRANSPORT CU INCARCARE FRONTALA PROFI LINE



5x GN 1/1



707661

### Thermo-BOX PENTRU CATERING PROFI LINE

- Ultra-usoara, rezistenta, cu sistem ce se inchide etans
- Capac detasabil - chiar si in cazul in care cutiile sunt stivuite
- Cu 5 santuri la distanta de 65 mm pentru introducerea containere GN
- Margini cu blocare profil, asigura stivuirea stabila, fara alunecare
- Se potrivesc pe Euro-paleti - 4 cutii pe nivel

cod	litri	mm int.	mm	lei
707661	66	535x310x(H)400	600x400x(H)490	599,99

### Exemplu de seturi



Se potrivește perfect pe paletii euro - patru cutii per strat.



### ELEMENT DE INCALZIRE

- Se poate incalzi pana la 90°C.
- Pentru a incalzi elementul, asezati-l intr-un recipient din otel inoxidabil si plasati-l intr-un cuptor cu convecție, maxim 90°C pentru max. 40 de minute.
- Contine ceara de parafina.

cod	GN	mm	lei
707784	GN 1/2	320x265x(H)30	93,49
707845	GN 1/1	530x325x(H)30	159,99



### ELEMENT DE RACIRE

- Pentru utilizare in termobox, mentine temperatura intre -12 pana la -10 °C timp de 3 pana la 4 ore, datorita placii eutectice.
- Inainte de utilizare: congelati la -18 °C timp de 24 de ore sau pana cand este inghetat.
- Pentru a verifica daca este gata, agitati elementul si cand simtiti si nu auziti nimic care se misca in interior, este gata.
- Contine apa si poliacrilat de sodiu.

cod	GN	mm	lei
707753	GN 1/1	530x325x(H)30	104,99
707760	GN 1/2	320x265x(H)30	69,99





## CUTIE CATERING THERMO PROFI LINE

- Ultra-usoare, rezistente, cu sistem deschidere sigilabil
- Potrivite pentru containere GN 1/1
- Cu 8 ghidaje la distanta de 61 mm pentru introducere containere GN
- Margini cu blocare profil asigura stivuirea stabila, fara alunecare

cod	litri	mm int.	mm	lei
707999	100	550x335x(H)545	635x465x(H)660	999,99



707999

### Exemplu de seturi



### ELEMENT RACIRE

- Pentru utilizare in termobox, mentineti temperatura intre 0 pana la 4 ° C timp de 3 pana la 4 ore datorita placii eutectice.
- Inainte de utilizare: congelati la -18 ° C timp de 24 de ore sau pana cand este inghetat. Pentru a verifica daca este gata, agitati elementul si cand simtiti, iar in momentul in care nu mai auziti niciun sunet, procesul este complet.
- Contine apa si poliacrilat de sodiu.

cod	GN	mm	lei
707777	GN 1/2	320x265x(H)30	61,69
707821	GN 1/1	530x325x(H)30	109,99



Cu manere ergonomice pentru transport



707968



### THERMOBOX PROFI LINE

- Perfect pentru transportarea produselor fierbinti sau reci
- Oferă un nivel ridicat de izolare
- Rezista la temperaturi cuprinse între -20°C și +110°C
- Cu manere îngropate pe ambele părți

cod	litri	mm int.	mm	lei
707906	40	538x338x(H)234	600x400x(H)285	144,99
707968	46	538x338x(H)257	600x400x(H)320	219,99
707951	53	625x425x(H)200	685x485x(H)260	229,99
707944	80	625x425x(H)300	685x485x(H)360	259,99



707814



### ADAPTOR GN 1/1

- Plasati acest adaptor cu element de racire in partea superioara a Thermobox-ului Kitchen Line si pastrati temperatura scazuta pentru perioade indelungate de timp
- Livrat fara element de racire
- Potrivit pentru 707906 si 707968

cod	mm	lei
707814	600x400x(H)85	119,99

707821

707814

707029

707012

707968



Cadrul ajuta la alinierea marginilor superioare ale tavilor GN de diferite inaltimi - ideal atunci cand recipientele sunt utilizate ca unitati de bain-marie sau rezervoare de refrigerare



707012



### RAMA EXTENSIE PENTRU CUTIE TERMOIZOLANTA PROFI LINE GN 1/1

- Pentru a creste capacitatea de 707906 si 707968 container de catering

cod	mm	lei
707012	600x400x(H)85	74,99
707029	600x400x(H)180	119,99





707982



Vezi filmul



Cadru foarte rezistent  
si cu slefuire



Cu manere ergonomice  
pentru transport



Diferenta dedicata pentru  
o deschidere usoara

### THERMOBOX PROFI LINE

- Perfect pentru transportarea produselor fierbinti sau reci
- Captuseala interioara speciala termoizolanta asigura rezistenta, usureaza curatarea si imbunatateste substantial durata de viata
- Cutia termica poate fi folosita pentru recipiente cu dimensiuni de pana la Gastronorm 1/1 - 530x325 mm
- Cutiile din polipropilena expandata [EPP] au o structura etansa care le confera proprietati izolatoare exceptionale, cu pana la 50% mai bune decat cele ale altor cutii termoizolante de la HENDI
- Rezista la temperaturi de la -20°C pana la 110°C
- Manerele practice integrate permit manipularea usoara a produsului
- Cutiile termice pot fi stivuite cu sau fara capace

cod	litri	mm int.	mm	lei
707982	39	538x338x(H)217	674x400x(H)287	334,99



Suprafata internă  
extrem de neteda



**CUTIE TERMOIZOLANTA CATERING PROFI LINE**

- Ideal pentru unitatile de catering care transporta si depoziteaza alimente calde sau reci.
- Pentru transportul produselor alimentare in ambalaje de unica folosinta sau ceramica.
- Datorita peretilor interiori profilati dedicati scoaterea containerelor este mai usoara.
- Structura solida si stabila pentru utilizare pe termen lung.
- Fabricat integral dintr-o singura bucata, fara lipiri sau imbinari.
- Foarte usoara, inchidere cu capac.
- Rezistenta ridicata la temperatura.
- Maner in carcasa.
- Spalarea in masinile de spalat vase este sigura pana la 80 ° C.
- Ajuta la introducerea HACCP in unitatile de catering.
- 100% reciclabila.

cod	litri	mm int.	mm	lei
707043	9	380x250x(H)95	440x310x(H)160	<b>134,99</b>
707050	15.6	380x250x(H)165	440x310x(H)230	<b>139,99</b>



707043

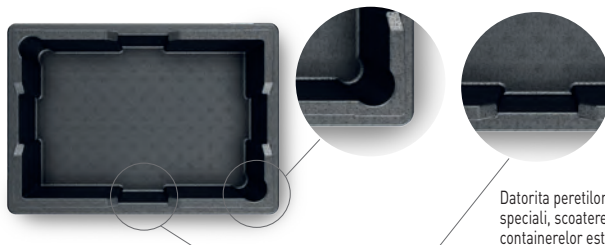

Datorita peretilor interiori speciali, scoaterea containerelor este mai usoara

**CUTIE TERMOIZOLANTA CATERING PROFI LINE SALTO**

- Fara capac, permite stivuirea cutiilor de pizza, ceea ce face posibil transportul mai multor pizza intr-o singura calatorie.
- Dupa eliberare acesta poate fi rotita la 180 de grade si poate fi folosit ca un capac cu alt container Salto.
- Ideal pentru transportul pizza in cutii.
- Manerale laterale integrate in carcasa pentru o transportare mai usoara.
- Structura stabila si stabila destinata utilizarii pe termen lung.
- Container realizat prin turnare, fara suruburi, cusaturi sau imbinari.
- Foarte usoare.
- Rezistenta ridicata la temperatura.
- Spalarea in masina de spalat vase este sigura pana la 80 ° C.
- Ajuta la introducerea HACCP in unitatile de catering.
- 100% reciclabile.

cod	litri	mm int.	mm	lei
707067	5.5	350x350x(H)45	410x410x(H)100	<b>74,99</b>
707074	9.8	350x350x(H)80	410x410x(H)135	<b>89,99</b>

707067



707074



707067 + 707074



Dupa rotirea cu 180 de grade, containerul poate fi utilizat ca un capac cu un alt recipient Salto



## CUTIE TERMOIZOLANTA PENTRU PIZZA PROFI LINE

- Ideal pentru transportul cutiilor de pizza si a produselor de cofetarie, pentru transportul prajiturilor.
- De asemenea, util in unitatile de catering pentru transportul si depozitarea alimentelor calde sau reci.
- Manererele laterale integrate cu carcasa pentru o reincarcare mai usoara.
- Profil special in interior pentru a scoate mai usor tavile.
- Structura stabila si rezistenta destinata utilizarii pe termen lung.
- Container realizat ca un intreg, fara suruburi, cusaturi sau imbinari.
- Ultra usor, inchidere cu capac.
- Rezistenta ridicata la temperatura.
- Maner integrat in carcasa.
- Culturi rotunjite pentru manipularea in siguranta.
- Spalarea la masina de spalat vase este sigura pana la 80 ° C.
- Ajuta la mentinerea normelor HACCP in unitatile de catering.
- Fabricat in intregime din polipropilena.
- 100% reciclabile.



707975

cod	litri	mm int.	mm	lei
707975	21	350x350x(H)175	410x410x(H)240	<b>182,99</b>
707098	21	420x420x(H)117	480x480x(H)165	<b>159,99</b>
707135	35	420x420x(H)200	480x480x(H)260	<b>179,99</b>
707142	33	535x535x(H)117	595x595x(H)165	<b>209,99</b>



707142

3x pizza ø50 cm



707098

3x pizza ø40 cm



707975

5x pizza ø32 cm

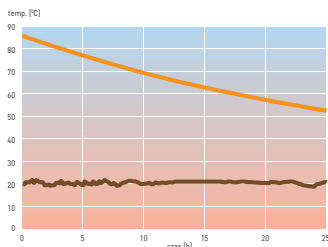

Scaderea/cresterea temperaturii in recipientul termoizolant, la sarcina maxima

— temperatura mediului ambient 85 °C

— temperatura initiala 20 °C



707135

5x pizza ø40 cm





707746

### RECIPIENT DE IZOLARE TERMICA KITCHEN LINE DIN PIOCELAN

- Ambalaje cu izolatie termica adecvate pentru contactul cu orice produs alimentar in conditii de racire sau inghet pe termen lung, inclusiv incalzirea pana la 70 ° timp de pana la 2 ore sau incalzirea pana la 100 ° C timp de pana la 15 minute sau pentru depozitare la temperatura camerei pentru pana la 30 de zile
- Confectionat din piocelan negru LSP EB prin formare
- Dotat cu manere de transport ergonomice
- Indeplineste cerintele legale si de sanatate aplicabile materialelor de ambalare destinate contactului direct cu produsele alimentare.

cod	litri	mm int.	mm	lei
707746	40	540x340x(H)230	600x400x(H)283	<b>119,99</b>
707425	46	538x338x(H)257	600x400x(H)320	<b>129,99</b>
707432	53	625x425x(H)200	685x485x(H)260	<b>177,99</b>
707456	80	625x425x(H)300	685x485x(H)360	<b>199,99</b>

THERMOBOX, RAFTURI, CARUCIOARE



707586



### RECIPIENT DE IZOLARE TERMICA KITCHEN LINE DIN PIOCELAN

- Containere cu izolatie termica cu huse adecvate din Piocelan negru
- Conceput pentru transportul si depozitarea pe termen lung a oricarui tip de alimente in conditii de racire sau inghet
- Se poate spala in masinile de spalat vase din restaurant.

cod	litri	mm	lei
707579	13	400x300x(H)173	<b>44,99</b>
707586	20	500x300x(H)213	<b>62,99</b>
707593	47	600x400x(H)296	<b>99,99</b>



6 incuietori - ideale pentru transportul meselor lichide



Materialul flexibil protejeaza recipientul si podeaua impotriva deteriorarii

## CONTAINER PENTRU TRANSPORT ALIMENTAR, IZOLAT DIN INOX, KITCHEN LINE

- Conceput pentru companiile de catering pentru a mentine calde alimentele si lichidele
- Mentine temperatura timp de pana la 6 ore
- Carcasa si capac termos din otel AISI 201, grosime 0,7 mm, finisaj satinat
- Rezervorul interior si interiorul capacului sunt fabricate din otel AISI 304, grosime 0,7 mm, lustruit
- Doua manere termo ergonomice, fiecare fixat cu sapte suduri pentru transport in siguranta
- Capac izolat cu maner si supapa de aerisire pentru o deschidere usoara
- Garnitura de profil, detasabila pentru o curatare usoara
- Capacul inchis cu 6 cleme
- Baza termosului este echipat cu o rama de cauciuc negru, care faciliteaza stivuirea termosului si, in acelasi timp, protejeaza impotriva deteriorarii termosului sau a suportului

cod	litri	mm	lei
707470	10	ø300x(H)265	404,99
707487	15	ø300x(H)340	459,99
707494	22	ø330x(H)370	519,99
707531	25	ø350x(H)385	589,99
707517	36	ø380x(H)455	699,99
707524	50	ø430x(H)455	749,99

Manere ergonomice

Supapa de aer





Vezi filmul

6 incuietori - ideale pentru transportul lichidelor



710203

Aceleasi diametre le fac mai usor de stivuit si transportat



Spatiu dintre pereti este umplut cu material izolator special, care mentine temperatura calda sau rece a alimentelor timp de pana la 6-8 ore



Vezi filmul

710227

710234

710326



710135

710333

710128

640

 HENDI





710203

- Spatiul dintre pereti este umplut cu un material izolat special, care asigura mentinerea temperaturii alimentelor de la 6 la 8 ore. Robinet din alama cu pipa la o inaltime de aproximativ 45 mm.



710227

- Capac dublu fixat cu o garnitura de etansare.
- Robinet din otel inoxidabil.
- Ventil de aerisire.
- Manere de transport ergonomice.

### CONTAINER TRANSPORT IZOLAT PROFI LINE

cod	litri	mm	lei
710104	10	ø330x(H)220	<b>516,99</b>
710111	15	ø330x(H)280	<b>556,99</b>
710203	20	ø330x(H)360	<b>625,99</b>
710210	25	ø330x(H)430	<b>700,99</b>
710302	35	ø330x(H)570	<b>798,99</b>
710319	50	ø480x(H)380	<b>982,99</b>

### CONTAINER TRANSPORT IZOLAT CU ROBINET PROFI LINE

cod	litri	mm	lei
710128	10	ø330x(H)220	<b>544,99</b>
710135	15	ø330x(H)280	<b>594,99</b>
710227	20	ø330x(H)360	<b>662,99</b>
710234	25	ø330x(H)430	<b>737,99</b>
710326	35	ø330x(H)570	<b>1149,00</b>
710333	50	ø480x(H)380	<b>1199,00</b>

#### Manere ergonomice



Supapa de aer



Capac dublu fixat cu o garnitura de etansare si echipat cu 6 incuietori

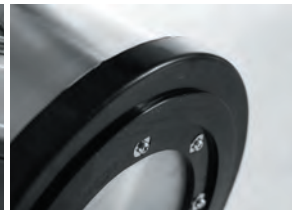

Materialul flexibil protejeaza recipientul si poadea impotriva deteriorarii





150 kg



812266

### RAFT DE DEPOZITARE DIN ALUMINIU PENTRU TAVI GN

- Tavile GN 1/1 se potrivesc intre suporturile din aluminiu (au latimea de 325 mm)
- Cadru din aluminiu anodizat
- Cu rafturi din polipropilena ce se pot spala la masina de spalat vase
- Usor de extins
- Capacitate greutate 150 kg, distribuita pe suprafata

cod	-	mm	lei
812266		1120x355x(H)1685	1169,00
812372	cartlig de extensie	15x42x(H)42	16,99

150 kg



812273

### RAFT DE DEPOZITARE DIN ALUMINIU

- Cadru realizat din aluminiu anodizat rezistent la coroziune.
- Cu 4 rafturi, fiecare raft este format din 3 elemente detasabile din polipropilena, care pot fi spalate in masina de spalat vase.
- Picioare reglabile pentru a asigura amplasarea nivelata.
- Conectati rafturile intre ele sau creati rafturi de colt cu cartligul de conectare disponibil in sortiment (cod: 812280).
- Capacitate maxima de incarcare per raft: 150 kg.

cod	-	mm	lei
812273		1280x405x(H)1685	1199,00
812280	cartlig de extensie	15x42x(H)42	15,99

Usor de extins



Containerele GN 1/1 se potrivesc direct intre suporturile din aluminiu



Rafturile din plastic pot fi curatate intr-o masina de spalat vase



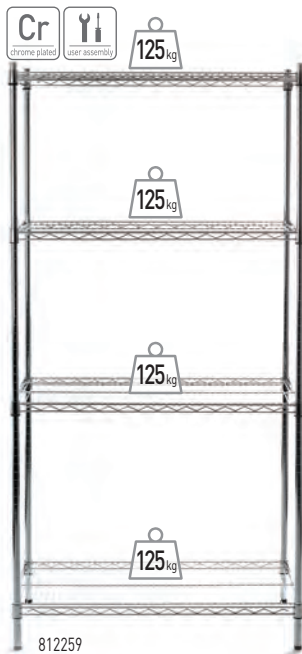

### RAFT DEPOZITARE - HEAVY DUTY

- 4 rafturi reglabile
- Greutate maxima pe raft - 125 kg
- Dotat cu picioare reglabile
- Fier placat cu crom

cod	mm	lei
812259	910x455x(H)1830	479,99



### CARUCIOR PLATFORMA

- In ciuda greutatii sale reduce poate transporta pana la 150 kg
- Pliabil pentru a minimiza dimensiunile la transport
- Cu 2 roti pivotante

cod	mm	lei
810514	730x480x(H)825	389,99

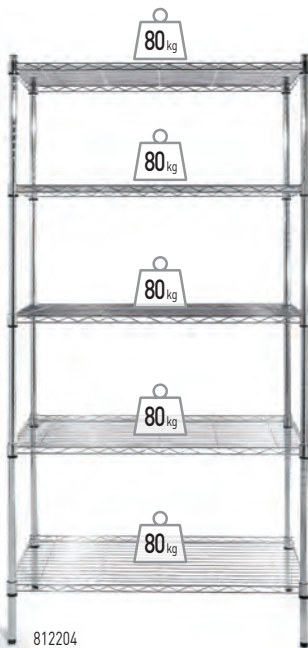

### RAFT DE DEPOZITARE CU 5 RAFTURI

- Fabricat din otel, disponibil cu finisaj placat cu crom sau finisaj acoperit cu pulbere neagra.
- Usor de asamblat, inaltimea rafturilor este usor de reglat.
- Furnizat cu 5 polite de sarma.
- Capacitate de incarcare pentru fiecare raft: 80 kg.
- Prevezut cu picioruse reglabile.

cod	culoare	mm	lei
812990	Negru	910x455	359,99
812204	Crom	x(H)1830	399,00



Se pliază pentru a minimiza dimensiunile de transport



810514



## MASINA DE SPALAT VASE 50X50 - COMANDA ELECTRONICA

- Extrem de usor de utilizat, intretinut si curatat
- Ideal pentru placi de spalat, tacamuri, sticlare, cesti, tavi
- Control electronic, control tactil, panou electronic
- Dozatoarele de detergent si agent de clatire si pompa ca standard
- AISI 304 carcasa din otel inoxidabil
- Se rotesc cu partea inferioara, spalare separata cu plastic si brate de clatire din otel inoxidabil
- Brate de spalare din plastic stationare sus, brate de clatire din otel inoxidabil
- Inchideti usa cu doua gratare cu microintrerupator pentru utilizare la deschidere
- Inaltime maxima de sticla care trebuie curatata: 325 mm
- Inaltimea maxima a placilor de spalat: 335 mm
- Termostat de siguranta pentru boiler/baie: pana la 105°C/ 99°C
- Termometru electronic pentru boilere si apa de baie
- Factor de izolare a pompei: IP 44
- Vertically ±10 mm, ø40 mm

### FUNCTII:

- Trei programe de spalare: 60, 120, 180 s. (Programul de spalare poate fi extins automat cu durata de incalzire a apei de clatire pana la +85°C)
- Programul de spalare a compartimentului masinii de spalat vase
- Poate fi clatit cu apa rece - adecvat in special pentru spalarea paharelor
- Sistem Thermo protector™ pentru a preveni clatirea cu apa rece - garanteaza pornirea clatirii la temperatura de 85°
- Sistem SOFT START - presiunea apei creste treptat protejand astfel vasele delicate
- Sistem de auto-diagnosticare in 8 puncte
- ECO - pentru consum redus de energie

### ACCESORII INCLUSE:

- 1 cos universal din sticla de 500x500x(H)105 mm
- 1 cu pini pentru farfurii adanci si adanci cu 5x8 buc., 500x500x(H)105 mm
- 1 cos pentru tacamuri 110x110x(H)130mm
- Detergent electric si dispozor pentru agentul de clatire
- Furtun de apa 1, 5 m lungime, cu conexiune cu filet mama 3/4"
- Pompa de scurgere
- Furtun de drenare
- Cablu electric fara fisa



max H  
335 mm

Masina de spalat vase 50x50  
- control electronic



Support  
podea



Pre-clatire

Masa de iesire  
pentru masina  
de spalat vase

Masa de intrare  
cu spatol  
pentru masina  
de spalat vase

Container  
rotund

Carucior pentru cosuri  
pentru masina  
de spalat vase

Cos pentru  
masina de spalat vase  
pentru articole din sticla

**DOZATOARE  
SI POMPA DE  
DRENARE  
INCLUDE**



## MASINA DE SPALAT PAHARE 40X40



Control electromecanic



Control electronic

In partea superioara brate de spalare si clatire separate, din otel inoxidabil



In partea inferioara brate de spalare si clatire separate, din otel inoxidabil

## MASINA DE SPALAT VASE 50X50



Control electromecanic



Control electronic

In partea superioara brate de spalare si clatire separate, din otel inoxidabil



In partea inferioara brate de spalare (plastic) si clatire (otel inoxidabil) separate

cod	control	dimensiuni cos	alimentare (V)	dozator clatire	dozator detergent	pompa evacuare	lei
230299	electromecanic	40x40	230	DA			5059,00
233009	electromecanic	40x40	230	DA	DA		5389,00
233016	electromecanic	40x40	230	DA		DA	5389,00
233023	electromecanic	40x40	230	DA	DA	DA	5699,00
230268	electronic	40x40	230	DA	DA	DA	6299,00
230305	electromecanic	50x50	400	DA			6129,00
230220	electromecanic	50x50	230	DA			6099,00
233030	electromecanic	50x50	400	DA	DA		6299,00
230237	electromecanic	50x50	230	DA	DA		6299,00
233047	electromecanic	50x50	400	DA		DA	6389,00
233054	electromecanic	50x50	400	DA	DA	DA	6499,00
230251	electromecanic	50x50	230	DA	DA	DA	6299,00
231753	electronic	50x50	400	DA	DA	DA	8199,00

		MASINA DE SPALAT PAHARE 40X40		MASINA DE SPALAT VASE 50X50	
<b>CONTROL</b>		electromecanic	electronic	electromecanic	electronic
<b>RECOMANDAT PENTRU</b>		cani, cani, pahare, tacamuri, farfurii		farfurii, tacamuri, pahare, cani, tavi	
<b>PARAMETRII SPALARE</b>					
Numaru/durata ciclurilor de spalare	s	1 – 120 <sup>1)</sup>		3/60, 120, 180 <sup>1)</sup>	
Capacitate	cosuri/h	30		60/30/20	
Inaltime maxima	mm	farfurii 290 / pahare 295		farfurii 325 / pahare 335	
Consumul de apa pe ciclu	l	2-2,5		1,7	
Temperatura apei de spalare	°C	62		62	
Temperatura apei de clatire	°C	85		85	
Boiler (capacitate/putere)	l / kW	3,5/2,5		6/6 (400 V) sau 6/3 (230 V)	
Rezervor (capacitate/putere)	l / kW	17/2,5		35/2,8 (400 V) sau 35/3,6 (230 V)	
Termostat de siguranta boiler	°C	105		105	
Termostat de siguranta rezervor	°C	99		99	
<b>ECHIPARE STANDARD</b>					
Termometru de apa in boiler		electronic		analog	
Brate separate de spalare/clatire		brate inox pentru spalare si clatire		brat plastic pentru spalare, brat inox pentru clatire	
Dozator agent de clatire		DA		DA	
Dozator detergent		OPTIONAL	DA	OPTIONAL	DA
Pompa de scurgere		OPTIONAL	DA	OPTIONAL	DA
Accesorii		1x cos universal 400x400x(H)150 mm pentru pahare 1x cos cu tije 400x400x(H)110 mm pentru farfurii 1x cos pentru tacamuri 110x110x(H)130 mm furtun de alimentare cu apa 1,5 m, cu racord filet interior 3/4". furtun de scurgere 2 m, Ø25 mm		1x cos universal 500x500x(H)105 mm pentru pahare 1x cos cu tije 500x500x(H)105 mm pentru farfurii 1x cos pentru tacamuri 110x110x(H)130 mm furtun de alimentare cu apa 1,5 m, cu racord filet interior 3/4". furtun de scurgere 2 m, Ø25 mm	
<b>PARAMETRI TEHNICI</b>					
Dimensiuni (LxAxH)	mm	470x510x(H)710		570x600x(H)830	
Putere	kW	2,8		6 (400 V) sau 3,6 (230 V)	
Putere pompa	KM	0,1	0,3	0,75	
Debit pompa		IP 44		IP 44	
Alimentare	V	230		400 sau 230	
Greutate	kg	39		57	
<b>FUNCTII</b>					
Program de spalare a sticlelor		DA		DA	
Auto-curatare		DA		DA	
„SOFT START” <sup>2)</sup>		DA		DA	
THERMO-PROTECTOR <sup>3)</sup>		DA		DA	
Auto-diagnosticare <sup>4)</sup>		DA		DA, 8-puncte	
ECO				DA	
<b>STRUCTURA</b>					
Corp inox AISI 304		DA		DA	
Usi izolate dublu-strat		DA		DA	
Picioare ajustabile Ø40 mm	mm	±10		±10	
<b>SUPORT PODEA</b>		222980		231050	
Dimensiuni	mm	470x500x(H)500		560x560x(H)500	
Capacitate		2 cosuri 400x400x(H)150 mm		2 cosuri 500x500x(H)105 mm	
lei		759,99		755,99	

<sup>1)</sup> Timpul indicat poate creste din cauza timpului necesar pentru ca apa din boiler sa atinga 85°C

#### FUNCTII MASINA DE SPALAT

<sup>2)</sup> „SOFT START” – activeaza pompa de apa la o presiune mai mica si creste treptat presiunea pentru a evita deteriorarea vaselor delicate

<sup>3)</sup> „THERMO-PROTECTOR” – previne clatirea cu apa rece – garanteaza clatirea la 85°C

<sup>4)</sup> Sistem de autodiagnosticare pentru verificarea rapida a starii masinii de spalare vase



## MASINA DE SPALAT VASE CU CAPOTA - CONTROL ELECTRONIC

- Extrem de usor de utilizat, de curatat si de intretinut
- Ideal pentru spalarea farfurilor, tacamurilor, sticlelor, paharelor, tavilor, recipientelor GN 1/1
- Control electronic
- **Dozatoare de detergent si de lichid de clatire si pompa de scurgere standard**
- Inaltimea maxima a placilor spalate 400 mm
- Inaltimea maxima a sticlei care trebuie curatata 395 mm
- Panou de control electronic tactil
- Carcasa din otel inoxidabil AISI 304
- Brate superioare si inferioare de spalare si clatire din otel inoxidabil
- Ridicarea capotei facilitata de arcuri incorporate
- Temperatura apei de spalare 60°C
- Temperatura apei de clatire, de scaldare 85°C
- Termometre electronice de apa pentru boiler si baie separat
- Termostat de siguranta pentru cazan/baie pana la 105°C / 99°C
- Factor de etansare a pompei: IP 44
- Instalarea in colt a masinii de spalare vase este posibila
- Conexiune apa: ¾"
- Picioare reglabile din otel inoxidabil de la 100 la 150 mm

### CARACTERISTICI:

- Trei programe de spalare: 60, 120, 240 s
- Program de spalare in compartimentul masinii de spalare vase
- Posibilitatea unei clatiri finale cu apa rece - utila in special la spalarea sticlei
- Sistemul „THERMO-PROTECTOR” pentru a preveni clatirea cu apa rece
- Sistem de autodiagnosticare in 8 puncte
- Sistem SOFT START - presiunea apei creste treptat protejand astfel vasele delicate
- Usa cu microcomutator pentru functionare cand hota este ridicata
- Functia ECO - reduce consumul de energie atunci cand dispozitivul nu este utilizat mai mult de 15 minute

### ACCESORII INCLUSE:

- 1 cos universal de sticla 500x500x(H)105 mm
- 1 cos cu ace pentru placi adanci si putin adanci cu 5x8 bucati, 500x500x(H)105 mm
- 1 cos pentru tacamuri 110x110x(H)130 mm
- Dozator de detergent si ajutor de clatire
- Pompa de drenaj
- Furtun pentru apa cu lungimea de 1,5 m, cu racord cu filet interior de ¾".
- Furtun de scurgere
- Cablu electric fara fisa



max H  
400 mm

## Masina de spalare vase cu capota - control electronic

### Masa de iesire pentru masina de spalare vase



Cos pentru  
masina de spalare vase  
pentru sticlărie

Carucior pentru  
cosuri pentru  
masina de spalare  
vase

DOZATOARE  
SI POMPA DE  
DRENARE  
INCLUDE

Pre-clatire

Masa de iesire  
pentru masina  
de spalat vase

Container  
rotund



## MASINA DE SPALAT VASE CU CAPOTA 50X50



230312



max H  
400 mm



231340



In partea superioara brate de spalare si clatire separate, din otel inoxidabil



In partea inferioara brate de spalare si clatire separate, din otel inoxidabil



cod	control	dimensiuni cos	alimentare (V)	dozator clatire	dozator detergent	pompa evacuare	lei
230312	electromecanic	50x50	400	DA			12099,00
233061	electromecanic	50x50	400	DA	DA		13099,00
231340	electronic	50x50	400	DA	DA	DA	13299,00

## MASINA DE SPALAT VASE CU CAPOTA 50X50

CONTROL		electromecanic	electronic
RECOMANDAT PENTRU		farfurii, tacamuri, pahare, cani, tavi, recipiente GN	
<b>PARAMETRII SPALARE</b>			
Numarul/durata ciclurilor de spalare	s	1 – 120 <sup>1)</sup>	3/60, 120, 180 <sup>1)</sup>
Capacitate	cosuri/h	30	60/30/15
Inaltime maxima	mm	farfurii 395 / pahare 400	
Consumul de apa pe ciclu	l	2-2,5	1,7
Temperatura apei de spalare	°C	62	
Temperatura apei de clatire	°C	85	
Boiler (capacitate/putere)	l / kW	7,4/7,5	13,5/7,5
Rezervor (capacitate/putere)	l / kW	68/6	
Termostat de siguranta boiler	°C	105	
Termostat de siguranta rezervor	°C	99	
<b>ECHIPARE STANDARD</b>			
Panoul de control electronic tactil			DA
Termometru de apa in boiler		analog	electronic
Brate separate de spalare/clatire		In partea superioara si inferioara brate de spalare si clatire separate din otel inoxidabil	
Dozator agent de clatire		DA	
Dozator detergent		OPTIONAL	DA
Accesorii		1x cos universal 500x500x(H)105 mm pentru pahare 1x cos cu tije 500x500x(H)105 mm pentru farfurii 1x cos pentru tacamuri 110x110x(H)130 mm	
Filtre de suprafata deasupra nivelului apei din bazin		4 piese	
Ecran suplimentar in fata pompei de admisie		DA	
Furtun de alimentare cu apa, lungime 1,5 m, cu filet interior de 3/4".		DA	
Cablu de alimentare fara priza		DA	
<b>PARAMETRI TEHNICI</b>			
Dimensiuni (LxAxH)	mm	750x880x(H)1390/1830	
Putere	kW	8,6	
Putere pompa	KM	1,5	
Debit pompa		IP 44	
Alimentare	V	400	
Greutate	kg	111	131,5
<b>FUNCTII</b>			
Auto-curatare			DA
„SOFT START” <sup>2)</sup>			DA
THERMO-PROTECTOR <sup>3)</sup>			DA
Auto-diagnosticare <sup>4)</sup>			DA, 8-puncte
ECO			DA
<b>STRUCTURA</b>			
Corp inox AISI 304		DA	
Usi izolate dublu-strat		DA	
Picioare ajustabile	mm	de la 100 la 150 mm	

<sup>1)</sup> Timpul indicat poate creste din cauza timpului necesar pentru ca apa din boiler sa atinga 85°C

### FUNCTII MASINA DE SPALAT

<sup>2)</sup> „SOFT START” – activeaza pompa de apa la o presiune mai mica si creste treptat presiunea pentru a evita deteriorarea vaselor delicate

<sup>3)</sup> „THERMO-PROTECTOR” – previne clatirea cu apa rece – garanteaza ca clatirea va incepe la 85°C

<sup>4)</sup> Sistem de autodiagnosticare pentru verificarea rapida a starii masinii de spalat vase

**MASINA DE SPALAT VASE MARI SI USTENSILE BUCATARIE, 50X60 CM, COMANDA ELECTRONICA, CU DOZATOR DE DETERGENT SI POMPA DE SCURGERE**



236574

MASINI DE SPALAT VASE

- Masina de spalat vase ideala pentru spalarea vaselor mari, recipientelor GN, tavi de cofetarie de 600x400 mm, tavi si tacamuri
- 3 programe de spalare controlate electronic: 3/60 s, 120 s, 180 s
- Temperatura de abur: 82 °C
- Touch, panou electronic
- Sistem automat de curatare
- Factor de scurgere a pompei: IP 44
- Cos mare 500x600 mm
- Carcasa cu doua straturi din otel inoxidabil AISI 304
- Brate de spalare si clatire din otel inoxidabil
- Greutate: 57 kg

**ECHIPAMENT:**

- Distributor de detergent
- Distributor de agent de clatire
- Termometru electronic pentru cazan
- Termometru electronic de baie
- Pompa de spalare de 1,2 kW
- Pompa de scurgere
- cos platou: 500x600x(H)105 mm
- cost universal: 500x600x(H)105 mm
- cos pentru tacamuri: 110x110x(H)130 mm

cod	V	W	mm	capacitate / putere cazan	capacitate / putere baie	lei
236574	400	7100	595x730x(H)1340	7,4 L/6 kW	58 L/6 kW	<b>16599,00</b>



## MASINI DE SPALAT SAMMIC CU CONTROL ELECTRONIC

18/10  
stainless steel

indoor

sammic

- Carcasa fabricata din otel inoxidabil AISI 304
- Filtrare in 3 pasi: suprafata, bazin, extractie - asigura o calitate constanta a apei de clatire
- 4 filtre de suprafata
- Design ergonomic cu culturi rotunjite care previn acumularea murdariei
- Control electronic intuitiv, ecran LCD IP65
- Pompa de clatire si scurgere incorporate
- Optiunea de a selecta un program dedicat tipului de vas spalat
- Program de auto-curatare
- Functie Soft-Start pentru vase delicate - crestere treptata a presiunii

- Functie Thermal Lock - clatirea paharelor are loc la temperatura optima pentru dezinfectare (85 grade)
- Functia wash plus - posibilitatea de extindere a timpului de spalare cu 30 de secunde aditionale
- Temperatura apei de spalare: de la 48 la 65 grade
- Temperatura de clatire: de la 65 la 87 grade
- Termostat al boilerului: intre 85 si 110 grade
- 3 cosuri incluse: universal, pentru farfurii, pentru tacamuri (100x100mm)
- Furtun de scurgere inclus
- NOATA: masina nu vine cu stecher instalat



NOU

1303107

### MASINA DE SPALAT PAHARE 40X40 UX 40B, CONTROL ELECTRONIC

- Masina de spalat pahare pentru cosuri de 40x40mm
- Bratele de spalare superioare si inferioare fabricate din plastic, cu tehnologie Hydroblade, detasabile
- Inaltimea maxima a vaselor 300mm
- Maner ergonomic integrat in carcasa usii
- 4 programe: 90, 120, 150, 180 minute, corespunzatoare dimensiunii cosurilor - 40, 30, 24, 20 pahare
- Puterea pompei de clatire: 250W (0.3 CP)
- Consum de apa pe ciclu de spalare: 1.9 litri
- Picioare ajustabile pana la 1 cm

cod	V	W	mm	lei
1303107	400	3050	470x540x(H)710	13149,00



NOU

1303227

### MASINA DE SPALAT VASE 50X50 50B, CONTROL ELECTRONIC

- Masina de spalat pahare pentru cosuri de 50x50mm
- Bratele de spalare superioare si inferioare fabricate din plastic, cu tehnologie Hydroblade, detasabile
- Inaltimea maxima a vaselor 380mm
- Maner ergonomic integrat in carcasa usii
- 4 programe: 90, 120, 150, 180, 240 minute, corespunzatoare dimensiunii cosurilor - 40, 30, 24, 20, 15 pahare
- Capacitate boiler/ putere: 8U/5kW
- Puterea pompei de clatire: 750W (1 CP)
- Consum de apa pe ciclu de spalare: 2.5 litri
- Picioare ajustabile pana la 1 cm

cod	V	W	mm	lei
1303227	400	5750	580x635x(H)835	17549,00

- Carcasa fabricata din otel inoxidabil AISI 304
- Filtrare in 3 pasi: suprafata, bazin, extractie - asigura o calitate constanta a apei de clatire
- 4 filtre de suprafata
- Design ergonomic cu colturi rotunjite care previn acumularea murdariei
- Control electronic intuitiv, ecran LCD IP65
- Pompa de clatire si scurgere incorporate
- Optiunea de a selecta un program dedicat tipului de vas spalat
- Program de auto-curatare
- Functie Soft-Start pentru vase delicate - crestere treptata a presiunii

- Functie Thermal Lock - clatirea paharelor are loc la temperatura optima pentru dezinfectare (85 grade)
- Functia wash plus - posibilitatea de extindere a timpului de spalare cu 30 de secunde aditionale
- Temperatura apei de spalare: de la 48 la 65 grade
- Temperatura de clatire: de la 65 la 87 grade
- Termostat al boilerului: intre 85 si 110 grade
- 3 cosuri incluse: universal, pentru farfurii, pentru tacamuri (100x100mm)
- Furtun de scurgere inclus
- NOATA: masina nu vine cu stecher instalat



**NOU**



**MASINA DE SPALAT CU CAPOTA 50X50 UX-100B, CONTROL ELECTRONIC**

- Masina de spalat pentru cosuri de 50x50mm
- Bratele de clatire superioare si inferioare sunt fabricate din otel inoxidabil cu tehnologia Hydroblade, detasabile
- Inaltime de admisie: 430mm
- Inaltimea maxima a vaselor: 440mm
- Capota usor de ridicat
- 5 programe selectabile: 60, 90, 100, 150, 210 minute corespunzator pentru fiecare capacitate a cosurilor: 60, 40, 36, 24, 17
- Capacitate boiler/ putere: 8l/7.5kW; capacitate tub 25l/2.5kW
- Pompa de clatire: 750W (1 CP)
- Consum de apa pe ciclu: 2.8l
- Picioare ajustabile intre: 140-190mm
- Inaltime cu capota ridicata: 2000mm

cod	V	W	mm	lei
1303325	400	8250	650x825x(H)1525	<b>26299,00</b>

1303325



### BATERIE CHIUVEȚA CU DUS

- Baterie din oțel inoxidabil lustruit
- Gura pivotantă cu un singur orificiu
- Reglementarea fluxului
- Gaura necesară în masă: 30mm
- Furtunuri de conectare: 3/8", lungime 400 mm
- Gama de scurgere: 190 mm
- Înălțimea bateriei: 370 mm.

cod	lei
810163	1099,00



810163

### BATERIE CHIUVEȚA CU DUS EXTENSIBIL

- Gura pivotantă cu un singur orificiu
- Reglementarea fluxului
- Gaura necesară în masă: 30 mm
- Furtunuri de conectare: 3/8", 350 mm lungime
- Înălțimea bateriei: 445 mm
- Robinetul este fabricat din oțel inoxidabil lustruit.

cod	lei
810170	1219,00



810170

### BATERIE CHIUVEȚA CU DUS EXTENSIBIL

- Fabricat din oțel inoxidabil
- Cu o singură gaură
- Duza pivotantă
- Reglementarea fluxului
- Lungime dus: 120 cm
- Orificiu necesar în tabel: ø 32 mm
- Furtunuri de conectare: 3/8", lungime 350 mm
- Gama gurii: 230 mm
- Înălțimea bateriei: 230 mm

cod	lei
810255	593,99



810255



231142

### DISPENSER REGLABIL PENTRU DETERGENT

- Dispenser electronic pentru detergent, cu cronometru pentru dozare.

cod	V	W	mm	lei
231142	230	8	82x103x(H)92	399,99



235973

### DOZATOR PENTRU DETERGENT LICHID REGLABIL

- Surub pentru reglarea debitului între 0 și 1,5 l/oră

cod	V	W	lei
235973	230	5	219,99



**BATERIE CU DUS CLATIRE**

- Dus rezistent la presiunea ridicata a apei
- Carcasa dus din material plastic
- Suport ajustabil
- Montare pe perete (scurtare optional)
- Conectare 1/2"
- Necesare orificiu montare chiuveta Ø 30 mm
- Distanța robinet 280 mm

cod	lei
970515	999,99

**BATERIE CHIUVEȚA CU DUS SUSPENDATĂ**

- Include: furtun de dus, arc de tensiune și cablu de oțel cu prindere
- Temperatura apei de alimentare: 5-85 °C
- Debit maxim de apă: 12 l/min la 3 bar
- Presiunea de funcționare a apei de alimentare: 0,5-7 bar
- Conexiune la robinetul de alimentare cu apă: 1/2"
- Piese din oțel cromat
- Lungimea furtunului 3 metri

cod	lei
810330	689,99

**BATERIE CHIUVEȚA CU DUS**

- Dusul este rezistent la debitul de apă de înaltă presiune
- Robinet cu o singură gaură, gura pivotantă
- Husă de dus din plastic
- Suport de perete care poate fi scurtat
- Este necesară gaura de masă: N / A
- Furtunuri de conectare: nu se aplică
- Înălțimea bateriei: 1010 mm.

cod	lei
810293	1109,00

**BATERIE CHIUVEȚA CU DUS**

- Dusul este rezistent la debitul de apă de înaltă presiune
- Robinet cu o singură gaură, gura pivotantă
- Husă de dus din plastic
- Suport de perete care poate fi scurtat
- Gaură necesară în masă: diametru 32,5 mm
- Furtunuri de conectare: 3/8", lungime 400 mm
- Înălțimea bateriei: 1060 mm.

cod	lei
810279	1419,00

**BATERIE CHIUVEȚA CU DUS**

- Dusul este rezistent la debitul de apă de înaltă presiune
- Husă de dus din plastic
- Suport de perete care poate fi scurtat
- Gaură necesară în masă: diametru 27 mm
- Furtunuri de conectare: 1/2", lungime 400 mm
- Înălțimea bateriei: 1030 mm.

cod	lei
810262	945,99



970508

### BATERIE CHIUVETA

- O singura gaura, controlata prin buton
- Furtunuri de conectare: 1/2"
- Este necesara o gaura pentru masa: ø30 mm
- Gura pivotanta, controlata prin buton
- Reach 250 mm

cod	lei
970508	314,99



970522

### BATERIE CHIUVETA

- Cu o singura gaura
- Furtun de conectare 3/8
- Diametrul gaurii necesar pentru montare: ø35 mm
- Atinge 215 mm

cod	lei
970522	354,99

### BATERIE PRE-SPALARE

- Robinet tip stalp
- Rezistent la fluxul de apa de inalta presiune
- Debitul maxim al apei: 17 L/min. la o presiune de 4 bari
- Maner de spalare din plastic
- Suport pentru coloane ajustabil
- Montare pe perete (scurtare optionala)
- Furtunuri de conectare: 1/2", cate 400 mm fiecare
- Este nevoie de o gaura in masa: ø 27 mm



cod	lei
970300	779,99



970300

### DUS MANUAL, UNIVERSAL, PENTRU CURATAREA CAMEREI DE CUPTOR

- Ideal pentru orice bucatar-sef pentru a mentine echipamentele.
- Potrivit pentru curatarea oricaror camere de cuptor: conventionale, cuptoare combinate, cuptoare, camere de prajire, placi de taiat, mese de lucru precum si orice dispozitive sau componente care pot fi spalate cu jet de apa.
- Un furtun lung de 2 metri ajunge la orice dispozitiv din gama sa.
- Manerul ergonomic, cu o supapa de golire, este confortabil de tinut.
- O prindere dedicata care poate fi asezata pe carcasa cuptorului (conform indicatiilor tehnicianului) sau pe perete folosind 3 suruburi.
- Jetul este impartit intr-un numar mai mic, utilizand un filtru care mareste suprafata de curatat acoperita.
- Ideal pentru apa la o temperatura de la 5°C la 85°C.
- Debit maxim de apa pana la 11 l/m la o presiune de 3 bari.



810323

- Presiunea recomandata a apei de alimentare: 3 bari.
- Presiunea de lucru a apei de alimentare: 0,5-7 bar.
- PA66 carcasa din nylon, piese din otel acoperite cu crom rezistent la coroziune.
- Racord de supapa de alimentare cu apa: 1/2".

cod	mm	lei
810323	56x42x(H)2000	204,99





979983

### DISPOZITIV DE ELIMINARE A DESEURILOR ALIMENTARE 550 W CU COMUTATOR

- Dispozitiv mic de eliminare a deseurilor.
- Pentru industria de restaurante.
- Element de antifonare.
- Flansa de montaj inox.
- Componente din inox.
- Motor de mare viteza: 4000 RPM.
- Este necesara o gaura de  $\varnothing 90$  mm.
- Cablu de alimentare inclus.
- Rulment auto-lubrificant.
- Asamblare rapida si usoara.
- Protectie detasabila impotriva stropirii si mufa de slefuit inclusa.
- Comutati cu tubul transparent.

cod	V	W	mm	lei
979983	230	550	$\varnothing 210 \times (H) 406$	<b>799,99</b>

Rotoare cu pale pivotante  
din oțel inoxidabil



Cot de evacuare pentru  
dispozitivul de salubritate



Aparatoare anti-stropire detasabila



APARATOARE DETASABILA  
IMPOTRIVA STROPILOR

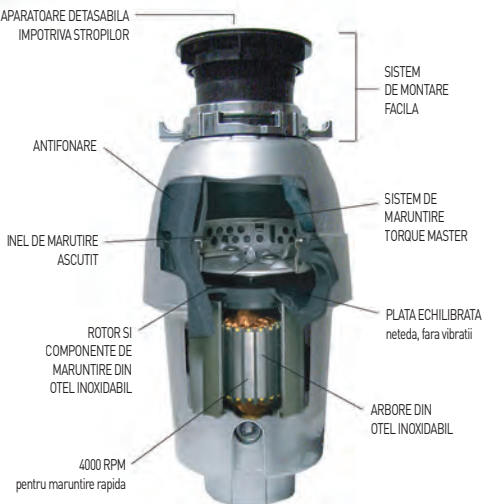



### FILTRU PENTRU GRASIME

- Impiedica grasimea sa blocheze sistemul de scurgere
- Pentru utilizare in interior (spatii de spalat vase, bucatarii)
- Otel inoxidabil
- Capac garnit fixat cu patru cleme
- Conexiuni de intrare/iesire Ø50 mm
- Doua deflectoare interioare verticale care separa grasimea si namolul
- Robinet cu bila pentru indepartarea grasimii
- Dimensiune compacta

cod	- litri	mm	lei
975718	300 l/h	30 650x346x(H)308	1429,00
975725	600 l/h	60 728x416x(H)398	1799,00
979945	1800 l/h	180 903x548x(H)629	2869,00



975718

### USCATOR MAINI

- Electric
- Activare prin senzor miscare
- Echipat cu cablu
- Carcasa alba din metal cu finisaj epoxidic rezistenta la impact

cod	V	W	mm	lei
221808	230	1500	239x208x(H)265	541,99



221808



810316

S.S.  
stainless steel

### SPALATOR CU ACTIONARE LA GENUNCHI

- Constructie din otel inoxidabil
- Cuva are un diametru de 350 mm si adancime de 123 mm
- Usor de actionat cu genunchiul
- Materiale conectare incluse

cod	mm	lei
810316	400x400x(H)450	769,99



Cu robinet operat la nivelul genunchiului

810309

18/10  
stainless steel

### SPALATOR CU ACTIONARE LA GENUNCHI

- Porniti apa intr-un mod igienic prin simpla apasare cu genunchiului pe panoul frontal.
- Echipat cu racord de apa calda si rece, care se afla sub panoul frontal.
- Chiuveata din otel inoxidabil 18/10.
- Dotata cu dispenser de sapun 0,5 l.
- Dimensiuni panou frontal: 285x(H)185 mm.
- Dimensiuni chiuveata: 330x230x(H)120 mm.
- Racord de apa: 1/2", orificiu de golire Ø 52 mm.

cod	mm	lei
810309	400x335x(H)570	799,99





809952



### DOZATOR INDUSTRIAL CU MONTARE PE PERETE PENTRU O ROLA MARE DE PROSOAPE DE HARTIE

- Destinat ca accesoriu la oricare si la pentru orice spatiu cu cerere mare de prosoape de hartie.
- Distributie a hartiei comoda si rapida, datorita limitatorului.
- Cadrul si elementul limitator sunt confectionate din otel inoxidabil AISI 304.
- Dispozitivul de fixare a rolei de hartie din polipropilena galbena.
- Dimensiune maxima a rolei: pana la Ø350x(H)300 mm.
- Greutate neta: 1,1 kg.
- Kitul include un set de montare pe perete.

cod	mm	lei
809952	400x250x(H)280	499,99



809921



### DOZATOR PENTRU SAPUN MONTAT PE PERETE

- Pentru toaletele publice din restaurante, hoteluri, scoli sau cladiri de birouri.
- Carcasa eleganta si durabila fabricata din otel AISI 304.
- Blocati, maneta si pompa confectionate din plastic POM.
- Fereastra transparenta din plastic ABS permite controlul nivelurilor dozatoarelor.
- Blocarea cu cheie protejeaza accesul la lichid.
- Volum: 1,2 L.
- Doza unica de sapun: 1,6 ml.
- Greutate neta: 1,4 kg.
- Un set de montare pe perete inclus in kit.

cod	mm	lei
809921	110x105x(H)320	559,99



663950



### SEMN ATENTIONARE „PODEA UMEDA”

- Atentionare in 5 limbi

cod	mm	lei
663950	300x460x(H)615	44,99



691083



### CARUCIOR PENTRU SPALATORIE

- Structura din otel cu puntea de rufe detasabila.
- 4 roti dintre care doua sunt rotative.

cod	mm	lei
691083	900x650x(H)850	416,99

## MASINI PENTRU LUSTRIRE TACAMURI

- Perfect pentru uscarea si lustruirea tacamurilor.
- Proces complet automatizat.
- Sterilizarea tacamurilor cu o lampa UVC bactericida.
- Forma rotunda a tamburului previne blocarea tacamurilor.
- Frana motor (numai la anumite modele).



1370043

- Ventilator 50 W (numai la anumite modele).
- Carcasa din otel inoxidabil.
- Modele de sine statatoare cu 2 roti si 2 picioare.
- Optional se pot comanda 2 roti.



1370048

### USCATOR / LUSTRUIT PENTRU TACAMURI 3000, BLAT DE MASA CU LAMPA UVC SI RACIRE MOTOR, MONOFAZAT

- Capacitate: 3.000 buc / h
- Cantitate standard de agent de lustruire: 3 kg
- Lampa germicida UVC
- Greutate: 43 kg

cod	V	W	mm	lei
1370043	230	683	484x664x(H)410	19849,00

### USCATOR-LUSTRUIT PENTRU TACAMURI 8000, DE SINE STATATOR CU LAMPA UVC SI RACIRE A MOTORULUI, TRIFAZAT

- Capacitate: pana la 8.000 buc / h
- Cantitate standard de agent de lustruire: 5 kg
- racirea motorului
- Lampa germicida UVC
- Frana motorului
- Greutate: 130 kg

cod	V	W	mm	lei
1370048	230	1208	633x791x(H)778	35349,00

### GRANULE DE LUSTRIRE BIODEGRADABILE PENTRU APARATE DE LUSTRIRE A TACAMURILOR

- Agentul de lustruire complet biodegradabil este derivat din porumb si ofera finisajul perfect pentru tacamurile din otel inoxidabil si argint.
- Calitatea inalta si fara praf absoarbe apa si indeparteaza depunerile de calcar de pe tacamuri.
- Utilizarea regulata previne oxidarea argintului si innoarea tacamurilor din otel.
- Nu indeparteaza zgarieturile mecanice.

cod	greutate (kg)	lei
976562	3	84,99

976562



## COSURI MASINA DE SPALAT VASE PROFI LINE



## COS PAHARE PENTRU MASINA DE SPALAT PAHARE

cod	numarul de compartimente/ dimensiuni	mm	lei
877050	9/150x150 mm	500x500x(H)104	<b>73,99</b>
877043	16/113x113 mm	500x500x(H)104	<b>80,99</b>
877036	25/90x90 mm	500x500x(H)104	<b>84,49</b>
877029	36/75x75 mm	500x500x(H)104	<b>91,99</b>
877012	49/63x63 mm	500x500x(H)104	<b>94,99</b>

## COS PENTRU MASINA DE SPALAT VASE

cod	numarul de compartimente/ dimensiuni	mm	lei
877302	-	500x500x(H)45	<b>34,99</b>
877548	9/150x150 mm	500x500x(H)45	<b>39,99</b>
877531	16/113x113 mm	500x500x(H)45	<b>39,99</b>
877524	25/90x90 mm	500x500x(H)45	<b>39,99</b>
877517	36/75x75 mm	500x500x(H)45	<b>39,99</b>
877500	49/63x63 mm	500x500x(H)45	<b>49,99</b>

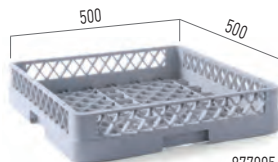

877005

## COS UNIVERSAL PENTRU MASINA DE SPALAT VASE

- Potrivit pentru pahare, oale, boluri, etc
- Structura permite un debit maxim de apa intre vase, in toate directiile

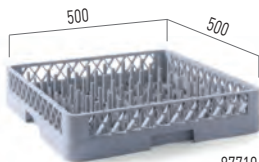

877104

## COS FARFURI PENTRU MASINA DE SPALAT VASE

- Structura permite un debit maxim de apa intre vase, in toate directiile
- Cu varfuri
- Spatiile dintre separatori creeaza o inclinare optima a farfuriilor pentru o spalare eficienta

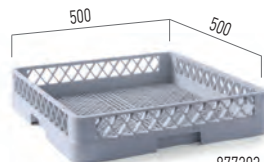

877203

## COS TACAMURI PENTRU MASINA DE SPALAT VASE

- Structura permite un debit maxim de apa intre vase, in toate directiile
- Plasa fina la partea inferioara ce impiedica caderea tacamurilor

cod	mm	lei
877005	500x500x(H)100	<b>68,99</b>

cod	mm	lei
877104	500x500x(H)100	<b>68,99</b>

cod	mm	lei
877203	500x500x(H)100	<b>67,99</b>

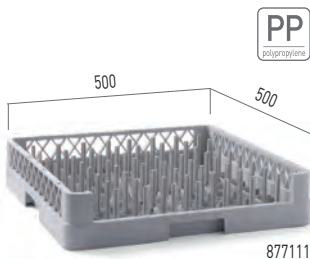

PP  
polypropylene

877111



871331

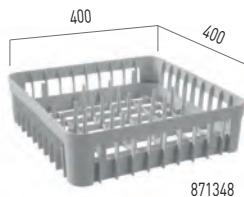

PP  
polypropylene

871348

### COS PENTRU TAVI

- Debit optim de apa intre tavi in toate planurile.
- Tavi de sustinere a posturilor.
- Design deschis pentru o spalare eficienta.

cod	mm	lei
877111	500x500x(H)100	68,99

### COS PAHARE PENTRU MASINA DE SPALAT VASE

- Structura permite fluxul maxim de apa intre pahare in toate directiile.

cod	-	mm	lei
871331		400x400x(H)150	62,99
871348	suportii verticali pt 40 pahare	400x400x(H)110	62,99



871324

PP  
polypropylene

### COS TACAMURI

cod	mm	lei
871324	125x84x(H)135	18,99



871300

PP  
polypropylene

### COS TACAMURI

cod	mm	lei
871300	110x110x(H)140	15,99



871102

PE  
polyethylene

### COS TACAMURI

- 8 sectiuni, cu maner

cod	mm	lei
871102	425x205x(H)150	46,99



552001

PP  
polypropylene

### CUTIE PENTRU DEBARASARE

- Gri, cu manere

cod	mm	lei
552001	555x410x(H)130	50,99

560044



### BONETA BUCATAR - 10 BUC

- Material PP netesut, din panza
- Partea de sus perforata
- Dimensiune reglabila

cod	mm	lei
560044	ø600x(H)230	23,99



877197

### CARUCIOR PENTRU COSURI PENTRU MASINA DE SPALAT VASE CU MANER

- 4 roți, 2 mobile cu frana și 2 fixe,
- maner din oțel inoxidabil.

cod	mm	lei
877197	575x545x(H)920	464,99



877197



877173

### CARUCIOR COSURI PENTRU MASINA DE SPALAT VASE

- 4 roți, 2 mobile cu frana și 2 fixe

cod	mm	lei
877173	575x545x(H)210	311,99



877180

### CAPAC PENTRU COSURI

cod	mm	lei
877180	500x500	54,99

**AMER★BOX®**

877791

### CAPAC PENTRU COSURI AMERBOX 500x500 MM

- Asigura cosurile cu vase spalate impotriva efectelor nedorite
- Igienizare crescuta a depozitarii vaselor prin minimizarea riscul de depuneri de gras și contaminare
- Potrivit pentru spalarea in masina de spalare vase

cod	mm	lei
877791	500x500x(H)35	49,99



### CARUCIOR MOBIL PENTRU COSURILE DE SPALAT VASE - 7 X 500X500 MM

- Pentru cosuri 500x500 mm cu 7 straturi - spatiul dintre acestea este de 200 mm
- Blocaje tavi pe ambele parti.
- Echipat cu patru role, dintre care doua au frane.
- Livrare in ambalaj plat.
- Sarcina maxima este de 100 kg, cand sarcina este distribuita uniform.

cod	mm	lei
810583	615x560x(H)1700	859,99



810583



877807

### CARUCIOR UNIVERSAL CAMRACK® 500X500 MM

- Destinat transportului rackurilor CAMRACK® universale de 500x500 mm
- Materie cu rezistenta la uzura, rugina și coroziune, cu 4 roți pivotante

cod	mm	lei
877807	500x500x(H)180	259,99

**AMER★BOX®**

281208



NUMARUL DE OUA  
**30**



NUMARUL DE OUA  
**10**



281253

S.S.  
stainless steel



Vezi filmul

### STERILIZATOR DE OUA

- Indispensabil pentru fiecare bucatarie din scoala, hotel, restaurant, cantina sau patiserie. Grilaj rezistent la UV situat in sertar.
- Ouale sunt sterilizate intr-un proces de iradiere cu unde de 253,7 nm lungime. Iradierea (sterilizarea) dureaza aproximativ 2,30 minute.

- Ouale pot fi folosite imediat dupa procesul de dezinfectie.
- Lampile se sting automat cand deschideti sertarul.
- Durata de viata a radiatorului UV: 7500 h.

cod	-	V	W	mm	lei
281253	10 oua	230	32	422x228x(H)188	<b>529,99</b>
281208	30 oua	230	78	358x512x(H)255	<b>1069,00</b>

281246



Vezi filmul

PMMA  
plexiglas

S.S.  
stainless steel

### STERILIZATOR UV

- Perfect pentru sterilizarea cutite, capacitate 14 cutite
- Fabricat din otel inoxidabil cu usa din plexiglas
- Echipat cu suport cutite, din otel inoxidabil
- Sterilizeaza prin lumina ultravioleta bactericida
- Echipat cu un intrerupator care previne functionarea cand usa este deschisa
- Timer integrat, reglabil pana la 60 minute

cod	V	W	mm	lei
281246	230	25	510x160x(H)625	<b>779,99</b>



281215

S.S.  
stainless steel

### STERILIZATOR CUTITE HENDI 30

- Perfect pentru sterilizarea cutitelor, capacitate de pana la 30 de cutite
- Dezinfectare cu radiatii UV bactericida
- Captura din otel inoxidabil
- Cronometru incorporat, pana la 120 de minute
- Greutate: 8 kg

cod	V	W	mm	lei
281215	230	15	482x155x(H)613	<b>1349,00</b>

# EXTREME

PROFESSIONAL



231388

## EXTREME OVEN CLEANER DETERGENT PROFESSIONAL PENTRU CUPTOR COMBI

- Concentrat puternic alcalin pentru curatarea periodica si zilnica a cuptoarelor combi.
- Recomandat pentru dispozitive cu optiune CIP.
- Indeparteaza eficient reziduurile uleioase arse, grasimea intarita, precum si depunerile organice si decolorarile care apar in timpul coacerii sau gatirii.
- Contine inhibitori de coroziune, necesita clatire.

cod	litri	lei
231388	10	189,99

## EXTREME BOOSTER CURATA- TOR PROFESIONAL PENTRU GRATAR SI CUPTOR

- Produs gata de utilizare, puternic alcalin pentru indepartarea zilnica a depunerilor uleioase si gudroase, a grasimilor arse si a decolorarilor organice.
- Curata si degreseaza.
- Recomandat pentru spalarea zilnica a gratarului, cuptoarelor, hotei.
- Ajuta la pastrarea stralucirii naturale a suprafetei.
- Fara miros.
- pH 14.

cod	litri	lei
975039	1	25,99



975039



Vezi filmul



## EXTREME STEEL DETERGENT PROFESIONAL PENTRU OTEL INOXIDABIL - 1L

- Potrivit pentru spalarea si intretinerea suprafetelor din otel inoxidabil.
- Elimina eficient murdaria, grasimea, amprentele si praful.
- Face suprafata curatata stralucitoare si lasa un strat protector care impiedica depunerile.

cod	litri	lei
979761	1	35,99



979761



# EXTREME

**PROFESSIONAL**



975046

975053



975015

975022

## EXTREME WASH DETERGENT PROFESIONAL DE VASE PENTRU MASINA DE SPALAT VASE COMERCIALA

- Concentrat puternic alcalin pentru masina de spalat vase in masinile de spalat vase comerciale si industriale.
- Curata indeparteaza in mod eficient reziduurile, depunerile si decolorarile produse de alimente.
- Nu este necesara pre-imbibare.
- Proprietati anticorozive.
- Neutru ca solutie.
- Recomandat pentru toate masinile de spalat vase domestice si industriale.
- pH 14.

cod	litri	lei
975053	10	<b>139,99</b>
975046	20	<b>239,99</b>

## EXTREME SHINE AGENT DE CLATIRE PROFESIONAL PENTRU VESELA SI ECHIPAMENTE DE CATERING

- Agent de clatire foarte concentrat pentru masinile de spalat vase, asigurand vesela stralucitoare.
- Indeparteaza mineralele (compusi de calciu si fier etc.) continute in apa, eliminand astfel urmele care apar pe vase.
- Potrivit pentru toate masinile de spalat vase comerciale si industriale.
- Recomandat pentru vase din sticla, ceramica, faianta, teflon, smalt, metal (argint, aluminiu, otel etc.).
- Sigur pentru vase pictate manual.
- Stralucire perfecta.
- Contine acizi organici.
- Nu este necesara stergerea.
- pH1.

cod	litri	lei
975015	10	<b>129,99</b>
975022	5	<b>89,99</b>



699317

### EXTREME ALU WASH SOLUTIE PROFESIONALA CONCENTRATA PENTRU SPALAREA MANUALA A VASELOR

- Detergent lichid cu efect de indepartare a spumei si protectie impotriva aluminiului
- Folosit in principal pentru orice tip de echipament si piese precum containere, tavi, tigai, vase de servit, aparate de bucatarie si tacamuri din aluminiu sau otel inoxidabil, materiale plastice si portelan
- Indeparteaza eficient grasimile, proteinele, amidonul si aluatul
- Are un efect de indepartare a spumei care garanteaza curatenia totala intr-un ciclu de spalare
- Va rugam sa verificati efectul detergentului pe aluminiu anodizat

cod	litri	lei
699317	20	304,99



975145

### EXTREME PURE SOLUTIE PROFESIONALA CONCENTRATA PENTRU SPALAREA MANUALA A VASELOR - 5L

- Concentrat cu pH neutru pentru spalare manuala.
- Sigur pentru orice fel de material: sticla, ceramica, acoperit cu email, otel, plastic, metale pretioase si neferoase.
- Inmoaie si indeparteaza reziduurile alimentare, grasimile si decolorarile.
- Lasa stralucire naturala.
- Garanteaza o densitate si vascozitate excelente.
- Parfum de lamaie.
- Prietenos cu pielea si mediul eficient si cu apa dura.

cod	litri	lei
975145	5	44,99



975008

### SOLUTIE PROFESIONALA PENTRU DETARTRARE SI CURATARE

- Pentru indepartarea minutioasa, zilnica a depunerilor de minerale si a calcarului din echipamentele profesionale de catering (boilere, sterilizatoare, masini de spalat vase etc.).
- Recomandat pentru toate tipurile de masini de spalat vase - masini de spalat vase cu hota, sub blat, modul, pe sticla si industriale.
- Contine acid fosforic.
- Elimina urmele.
- Fara miros, prietenos cu suprafata, necesita clatire.

cod	litri	lei
975008	1	22,99

### EXTREME WASH & SHINE SET DE CURATARE SI CLATIRE PENTRU MASINILE DE SPALAT VASE COMERCIALE (975053+975022)

- Setul include detergent de spalat vase 975053 si agent de clatire 975022.

cod	lei
979792	184,99



979792

# EXTREME

PROFESSIONAL



976678

976661

## PRODUS DE CURATARE PENTRU SISTEMUL DE CURATARE EXTREME MILK SI PENTRU CAFETIERE AUTOMATE

- Pentru curatarea dispozitivului pentru in toate espressoarele cu sisteme de spumare sau accesorii.
- Indeparteaza proteinele si grasimile vechi, cristalizate.
- Purjeaza continuu liniile.
- O sticla cu un dozator convenabil.

cod	litri	lei
976661	0,25	39,99
976678	1	53,99

MASINI DE SPALAT VASE



231296



## EXTREME MILK FROTHER CLEANER SOLUTIE PROFESIONALA PENTRU CURATARE UNITATE SPUMARE

- Recomandata pentru toate aparatele de cafea standard, cu unitate spumare
- Indeparteaza depunerile de grasime si proteine
- Nu afecteaza gustul cafelei
- Curata si protejeaza
- Indeparteaza reziduurile
- Doar pentru uz profesional

cod	litri	lei
231296	1	27,99

## NOUA FORMULA, AGENT PROFESIONAL DE CURATARE A ESPRESSOARELOR EXTREME COFFEE TABLETS

- Pentru indepartarea diferitelor contaminari acumulate in evacuari, filtre.
- Produsul curata, de asemenea, rezervoarele de apa calda si recipientele de cafea.
- Curatarea trebuie repetata la fiecare 2 saptamani sau 250 de cesti de cafea.
- NOTA: Acest produs nu indeparteaza calcarul.

cod	ambalat pe	lei
976630	25 tablete	33,49
976647	40 blistere a 10 tablete	259,99
976654	1 blister a 10 tablete	12,99



976630



976654



976685

## FORMULA NOUA, EXTREME COFFEE LAB, O PUDRA PROFESIONALA DE CURATARE PENTRU CAFETIERE CU CAFEA BOABE

- Pentru curatarea interiorului espressorului.
- Elimina depunerile de cafea dura, de asemenea, preferabila pentru curatare periodica - indeparteaza petele de pe portelan.

cod	greutate (kg)	lei
976685	0,75	54,99

## EXTREME DECALCIT PUDRA PROFESIONALA PENTRU DECALCFIERE

- Pulbere speciala de decalcifiere pentru toate tipurile de masini de spalat vase comerciale
- Potrivita si pentru recipiente din aluminiu
- Recomandat pentru aparatele de cafea, ceainicele, recipientele, cuptoarele si alte dispozitive susceptibile la calcar.

cod	-	lei
979754	0,5 kg	44,99



976692

## AGENT DE DECALCFIERE EXTREME, UN AGENT PROFESIONAL DE INDEPARTARE A DEPURERILOR - 30 COMPRIMATE INTR-UN AMBALAJ

- Pentru indepartarea depunerilor de calcar din aparatele electrocasnice.
- Recomandat pentru utilizarea in espressoare, fierbatoare, cuptoare si alte dispozitive unde se formeaza depuneri de calcar.

cod	-	lei
976692	30 comprimate	83,99



979754



# UNIQ

Buffet reinvented



design by  
Robert Bronwasser



red dot winner 2024



MASINI DE SPALAT VASE



# EXTREME

PROFESSIONAL

## EXTREME NATURAL GRILL CLEANER SOLUTIE PROFESIONALA DE CURATARE PENTRU GRATARE SI GRILLURI ROLA

- Compozitie 100% naturala.
- Pentru utilizare profesionala in gastronomie si industria alimentara.
- Ideal pentru: restaurante fast-food, benzinarii, camioane alimentare, magazine alimentare, bistro-uri.
- Indepartarea usoara si rapida a impuritatilor organice si non-organice, inclusiv a uleiurilor.
- Pentru indepartarea petelor grase, dar nu si a petelor arse.
- Curatare si degresare neinvaziva - fara niciun risc de deteriorare sau decolorare a stratului antiaderent de pe grilele rulante.
- Inodor, non-toxic - sigur pentru utilizare in incaperi mici.
- Nu contine COV (compusi organici volatili) si solventi pe baza de hidrocarburi.
- Certificat de NSF N8 pentru a atesta siguranta utilizarii echipamentelor de procesare a alimentelor.
- Usor de utilizat: pur si simplu pulverizati suprafata si stergeti cu o laveta.
- Clatiti cu apa dupa utilizare.
- Nu este necesara lasarea petelor sa se inmoaie - aceasta patrunde rapid in murdarie.

cod	litri	lei
976814	1	89,99



976814



Vezi filmul

## EXTREME BOOSTER CURATATOR PROFESIONAL PENTRU GRATAR SI CUPTOR

- Produs gata de utilizare, puternic alcalin pentru indepartarea zilnica a depunerilor uleioase si gudroase, a grasimilor arse si a decolorarilor organice.
- Curata si degreseaza.
- Recomandat pentru spalarea zilnica a gratarului, cuptoarelor, hotei.
- Ajuta la pastrarea stralucirii naturale a suprafetii.
- Fara miros.
- pH 14.

cod	litri	lei
975039	1	25,99



976807





238073

**NOU**

### FILTRU PENTRU MASINA DE GHEATA 3.0

- Filtrare completa a apei, concepute pentru masini de gheata incorporate in blat
- Inlatura impuritatile mai mari de 20 de microni
- Inlatura clorul din apa si derivatele acestuia - imbunatatest gustul si mirosul apei
- Neutralizeaza carbonatul de calciu - previne depunerile de calcar
- Filtrul poate fi montat pe perete sau plasat pe podea dupa conectarea la apa
- Eficienta: 12 luni sau 30.000 litri
- Presiunea maxima admisa: 6 bari
- Flow maxim: 1l/ min
- Duritatea maxima a apei: 500ppm
- Interval de temperatura: 2-38 grade
- Conexiune la apa: 3/4"
- Cartusele se pot achizitiona si separat: cod 238080

cod	lei
238073	665,99



238080

**NOU**

### CARTUS PENTRU FILTRUL DE APA PENTRU MASINA DE GHEATA 3.0

- Rezerva cartus pentru filtru de apa
- Inlatura impuritatile mai mari de 20 de microni
- Inlatura clorul din apa si derivatele acestuia - imbunatatest gustul si mirosul apei
- Neutralizeaza carbonatul de calciu - previne depunerile de calcar
- Eficienta: 12 luni sau 30.000 litri
- Presiunea maxima admisa: 6 bari
- Debit maxim: 1l/ min
- Duritatea maxima a apei: 500ppm
- Interval de temperatura: 2-38 grade
- Compatibil cu filtrul pentru masinile de gheata (cod:238073)

cod	lei
238080	104,99

### FILTRU APA CU MEMBRANA OSMOZA

- Filtre cu membrana de osmoza inversa pentru filtrarea apei
  - rezultatul final este o apa complet pura din punct de vedere chimic, demineralizata.
- Apa purificata prin osmoza inversa se traduce prin:
  - lipsa necesitatii de lustruire manuala a sticlei si a tacamurilor,
  - o actiune detergenta mai puternica, reducand astfel utilizarea agentilor de curatare si a polizoarelor,
  - o durata de viata prelungita si o eficienta energetica sporita a aparatelor conectate la apa.
- Pentru utilizare in gastronomia profesionala - conceput pentru echipamente profesionale de alimentatie publica (nu neaparat pentru purificarea apei potabile din cauza gustului dupa purificare).
- Membrana permite doar trecerea moleculelor de apa - are pori cu un diametru de 0,0001 micrometri.
- Membrana este instalata din fabrica in aparat - nu este nevoie de autoasamblare.
- Design compact - carcasa contine deja filete pentru conectarea prefiltrului.

- Pompa incorporata, controlata de senzori de presiune.
- Diametrul de intrare a apei: 3/4".
- Presiune de functionare: de la 2,2 la 6 bar.
- Duritatea maxima a apei: 1500ppm.
- Concentratie maxima de clor: 0,3ppm. Intervalul de pH al apei de alimentare: 2-11.
- Reducerea impuritatilor si a duritatii pana la 95%.
- Livrat cu un furtun de conectare a apei.
- Principiile de functionare ale osmoziei inverse:
  - apa care trece prin cartusul de prefiltrare este purificata de contaminantii mai mari de 5 microni (nisip, rugina etc., precum si de clor),
  - apoi este trecuta prin membrana osmotica, care actioneaza ca o bariera pentru contaminantii organici si anorganici, metale grele, elemente radioactive si substante cancerigene,
  - apa curata este directionata catre filtrul final,
  - dupa filtrarea moleculara, apa trece printr-un cartus de mineralizare, care o satureaza si mai mult cu ioni de saruri minerale.

**NOU**

238035

**FITRU OSMOZA INVERSA 1.0**

- Carcasa fabricata din material sintetic
- Eficienta maxima pentru apa cu temperatura de 25 grade si presiune de 4 bari, cu duritate de 250ppm: 1.5l/ min
- Echipat cu un pre-filtru cu carbon activat si un filtru final cu sedimentare
- Cartusele sunt disponibile si separat: pre-filtru (cod 238066) si filtru final (cod: 238059)

cod	V	W	mm	lei
238035	230	108	360x130x(H)445	<b>2569,00</b>

**NOU**

238028

**FITRU OSMOZA INVERSA 2.0**

- Carcasa din otel inoxidabil
- Eficienta maxima pentru apa cu temperatura de 25 grade si presiune de 4 bari, cu duritate de 250ppm: 2.9l/ min
- Echipat cu un pre-filtru cu carbon activat
- Filtrul final se achizitioneaza separat, cod 238042

cod	V	W	mm	lei
238028	230	108	420x150x(H)445	<b>6999,00</b>

**NOU****PREFILTRU PENTRU FILTRUL CU OSMOZA INVERSA 1.0**

- Filtru cu carbon - conexiune 3/4"
- Reduce nivelul impuritatilor si clorului prezent in apa - protejeaza membrana osmotica
- Durata de viata: aproximativ 6 luni (11.000 litri) in functie de calitatea apei
- Debit maxim de apa: 3.8l/ min
- Presiune maxima: 6 bari

cod	lei
238066	<b>45,99</b>

**NOU**

238059

**CARTUS PENTRU FILTRUL CU OSMOZA INVERSA 1.0**

- Filtru pentru sedimente - permite conectarea cu un furtun de 3/4"
- Durata de viata: aprox. 6 luni (11.000 litri), in functie de calitatea apei
- Debit maxim: 3.8l/ min
- Presiune maxima: 6 bari
- Conceput pentru filtrul HENDI cu osmoza inversa 1.0 (cod: 238035)

cod	lei
238059	<b>33,99</b>

**NOU**

238042

**PREFILTRU PENTRU FILTRUL CU OSMOZA INVERSA 2.0**

- Filtrul contine carbon activat
- Inlatura eficient impuritatile mai mari de 5 micrometri
- Inlatura clorul si derivatele toxice ale acestuia, imbunatatin gustul si mirosul apei
- Durata de viata: 6 luni (11.000 litri), in functie de duritatea apei
- Debit maxim: 3.8l/ min
- Presiune maxima: 6 bar.
- Conectare rapida cu fitting de 1/4"

cod	lei
238042	<b>53,99</b>



## FILTRE HENDI PENTRU APA

**NOU**



### MAI MULT PROFIT CU FILTRELE HENDI PENTRU APA

- Dedurizeaza si decontamineaza apa
- Reduce nivelul clorului
- Protectie bacteriostatica
- Previne ruginirea echipamentelor

### AVANTAJELE FILTRELOR HENDI PENTRU APA



Instalare rapida



Adaptor pentru bypass: 0-70%



Inel de carbon pentru filtrare eficienta



Kit de instalare inclus - nu necesita ustensile suplimentare pentru montare



Un filtru poate fi utilizat pentru mai multe echipamente simultan



Mentineră optimă a igienei



- Recomandat in special pentru utilizare impreuna cu: cuptoare cu aburi de convecție, espressoare, aparate de cuburi de gheata, automate de vanzare, masini de spalat vase de sub blat.
- Tehnologia de tratare a apei:
  - eliminarea ionilor de calciu si magneziu responsabili pentru duritatea apei (eliminarea depunerilor de calcar - reziduuri de calciu)
  - decarbonizare, ceea ce inseamna indepartarea carbonatului de calciu si a carbonatului de magneziu.
- Efect: eliminarea mirosurilor si aromelor nedorite din apa, reducerea cantitatii de clor, scaderea duritatii, efect bacteriostatic care au toate ca rezultat obtinerea unui gust mai bun al apei/bauturilor/preparatelor si protejarea echipamentelor de catering.
- Filtrul consta din:
  - primul filtru de carbon retine particule mari, clor, materie organica si alte substante care afecteaza negativ mirosul si gustul apei,
  - filtru de rasina care reduce duritatea carbonatilor,
  - al doilea filtru de carbon retine particulele mici,
  - filtru care separa suspensia.
- Cap incorporat cu o setare posibila de bypass intre: 0-70% (nu este nevoie sa achizitionati capul separat).
- Capacitatea de productie: filtrul trebuie inlocuit la 365 de zile de la instalare pentru a mentine siguranta bacteriologica / sau dupa depasirea valorii maxime de iesire.
- Putere maxima: depinde de alcalinitatea apei si de setarea bypass-ului

### Filtrele HENDI sunt potrivite si pentru echipamente de la alti producatori



Masini de spalat vase



Cuptoare cu convecție si abur



Aparate de cafea



Aparate pentru gheata





### POTENTIALUL DE FILTRARE

Numarul mare de pori prezenti in filtrul de carbon retine sedimentele organice, compusii chimici etc.

### Carbon activ

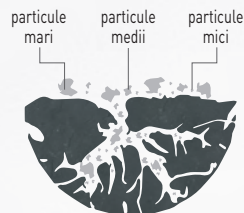

- Debitul maxim al apei - in functie de model:
  - 3 l/min. (cod: 237878),
  - 4 l/min. (cod: 237793),
  - 5 l/min. (cod: 237861).
- Intervalul temperaturii apei la intrare: 5-35°C.
- Presiune de functionare: 2-6 bari.
- Conectori: 3/8" M.

- Instalarea si operarea numai in pozitie verticala.
- Pentru instalarea si functionarea corecta a filtrului, va recomandam sa achizitionati:
  - Set de instalare pentru filtrele de apa HENDI (cod: 237908),
  - Debitmetru electronic de apa pentru filtrele HENDI (cod: 237915).



## ALEGE FILTRUL HENDI CORECT



**NOU**



cod	237892	237885	237878	237793	237861
nume	Filtru de apa XS	Filtru de apa S	Filtru de apa M	Filtru de apa L	Filtru de apa XL
lei	<b>197,99</b>	<b>313,99</b>	<b>468,99</b>	<b>665,99</b>	<b>900,99</b>
tehnologie	decarbonizare				
presiunea de lucru   temperatura apei de intrare	2-6 bar   5-35°C				
debit	1 l/min	2 l/min	3 l/min	4 l/min	5 l/min
dimensiuni	ø87x(H)302 mm	ø87x(H)562 mm	ø135x(H)384 mm	ø173x(H)395 mm	ø173x(H)463 mm
greutate (uscat/ud)	1,0/1,6 kg	1,8/2,8 kg	2,8/4,2 kg	4,6/6,9 kg	7,7/12,5 kg
conector (admisie/iesire)	M 3/8"				
pozitie de lucru   uz	verticale				
10° dH - 10% By-pass	787	1 798	3 370	5 056	6 742
10° dH - 30% By-pass	1 010	2 310	4 334	6 500	8 668
10° dH - 40% By-pass	1 180	2 700	5 050	7 585	10 100
10° dH - 0% By-pass	708	1 618	3 034	4 551	6 067

237915



**NOU**



### MONITOR DEBIT APA PENTRU FILTRE HENDI

- Dupa setarea parametrilor de productie (0-9900 L) - monitorul va numara litri de apa generati
- Monitorul poate fi setat pentru a indica timpul ramas de utilizare a filtrului (0-720 zile)
- Posibilitatea de a urmari numarul debitul de apa in L/min
- Cu 3 tipuri de alarma:
  - cand output-ul filtrului este mai mic de 113L sau mai are mai putin de 7 zile de functionare
  - cand durata de viata a filtrului ajunge la 0
  - baterie joasa
- Pozitie verticala de instalare
- 2 baterii AAA incluse
- Dimensiune conectori: 3/8"

cod	mm	lei
237915	110x53x(H)70	<b>294,99</b>

237908



**NOU**



### KIT INSTALARE FILTRE HENDI PENTRU APA

- Kitul este conceput pentru filtrele HENDI S, M, L si pentru codurile: 237793, 237861, 237878, 237885, 237892
- Setul include
  - furtun pentru apa
  - tub de aerisire
  - 2 conectori
  - 5 valve

cod	mm	lei
237908	ø18	<b>192,99</b>

## FILTRE DE APA



cod	1013637	1002952	1002949	1033041
nume	filtru PURITY C by-pass 0-70% 3/8"	filtru PURITY C by-pass 30% 3/8"	filtru PURITY C by-pass 0% 3/8"	debitmetru electronic de apa
uz	universal	pentru aparatele de cafea	pentru cuptoare si masini de gheata	
lei	249,99	179,99	179,99	449,99

**Cap de filtrare**  
La sfarsitul procesului de filtrare fibra de filtrare opreste particulele fine

**Filtrare cu carbon activ**  
Toata apa, curge printr-un filtru cu carbon activ, care elimina substantele care modifica gustul si aroma

**Reducerea duritatii carbonatului**  
Aceasta parte a filtrului PURISTY C Quell ST reduce duritatea carbonatului din apa si impiedica depunerile de calcar

**Prefiltrare**  
Prefiltrul opreste particulele mari.

cod	1002730	102828	102826	1002045	1012446
nume	PURITY C 50	PURITY C 150	PURITY C 300	PURITY C 500	PURITY C 1100
lei	279,99	409,99	599,99	899,99	1279,00

tehnologie	decarbonizare				
presiunea de lucru   temperatura apei de intrare	8,6 bar   4-30°C				
debit	60 l/h (0.25 bar)	60 l/h (0.25 bar)	60 l/h (0.25 bar)	100 l/h (0.5 bar)	100 l/h (0.5 bar)
dimensiuni (W x D x H)	119/108/268 mm	117/104/419 mm	125/119/466 mm	144/144/557 mm	184/184/557 mm
greutate (uscata/ud)	1,0/1,6 kg	1,8/2,8 kg	2,8/4,2 kg	4,6/6,9 kg	7,7/12,5 kg
conector (admisie/iesire)	3/8"				
pozitie de lucru   uz	orizontala si verticala   poate fi utilizat in legatura cu sistemul de dedurizare a apei				

Performanta depinde de tipul de cap

<b>PURITY C 0-70% filtru cu reglare by-pass</b>					
iesire: masini de gatit cu abur, cuptoare (duritate carbonatata 10 dH/by-pass setata la 40%)	960 l	2 408 l	4 000 l	6 800 l	11 500 l
iesire: masini de gatit cu abur, cuptoare (duritate carbonatata 10 dH/by-pass setata la 10%)	660 l	1 656 l	2 750 l	4 675 l	7 906 l
<b>PURITY C 30 % filtru cu reglare by-pass</b>					
iesire: duritate carbonatata 10 dH	831 l	2 086 l	3 464 l	5 889 l	9 960 l
<b>PURITY C 0 % filtru cu reglare by-pass</b>					
iesire: duritate carbonatata 10 dH	600 l	1 505 l	2 500 l	4 250 l	7 188 l





cod	1023325	1033041
nume	BRITA PURITY C STEAM by pass	debitmetru electronic de apa
uz	reglarea debitului de apa in patru etape	
lei	289,99	449,99

#### Cap de filtrare

La sfarsitul procesului de filtrare fibra de filtrare opreste particulele fine

#### Filtrare cu carbon activ

Toata apa, curge printr-un filtru cu carbon activ, care elimina substantele care modifica gustul si aroma

#### Reducerea duritatii carbonatului

Aceasta parte a filtrului PURISTY C Quell ST reduce duritatea carbonatului din apa si impiedica depunerile de calcar

#### Prefiltrare

Prefiltrul opreste particulele mari.

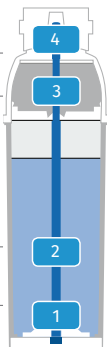

cod	1023320	1023328
nume	BRITA PURITY C 500 STEAM	BRITA PURITY C 1100 STEAM
lei	899,99	1299,00

presiunea de lucru   temperatura apei de intrare	decarbonizare	
debit	2 - 8,6 bars   4-30°C	
dimensiuni (W x D x H)	300 l/h	300 l/h
greutate (uscat/ud)	ø144x(H)557 mm	ø184x(H)557 mm
conector (admisie/iesire)	3/8"	
pozitie de lucru   uz	orizontala si verticala   poate fi utilizat in legatura cu sistemul de dedurizare a apei	

Performanta depinde de tipul de cap

#### EXEMPLU DE PERFORMANTA IN LITRI DE CARTUSE BRITA PURITY C STEAM

Duritatea apei °dH (scara germana)	BRITA PURITY C 500 STEAM			BRITA PURITY C 1100 STEAM		
	Setare de reglare BY-PASS			Setare de reglare BY-PASS		
	0	1-2	3	0	1-2	3
5	7083	7792	8677	11980	13178	14676
10	4250	4675	5206	7188	7907	8697
15	2833	3117	3471	4792	5271	5798
20	2125	2338	2603	3594	3953	4349
25	1700	1870	2083	2875	3653	3479
30	1417	1558	1735	2396	2636	2899



## APARATE DE DEDURIZARE A APEI (SEMI-)AUTOMATIC

- Utilizarea dedurizatoarelor de apa ajuta la extinderea ciclului de viata al echipamentelor de catering
- Dedurizatoarele se bazeaza pe un procedeu de schimb de ioni in care ionii de calciu si magneziu care cauzeaza duritatea apei sunt retinuti de rasina catanonica din interiorul dedurizatorului. Ajuta la reducerea costurilor de intretinere datorita prevenirii eficiente a depozitelor de calcar
- Dispozitivul este echipat cu un cap de control care face posibila configurarea parametrilor de lucru ai sistemului de dedurizare a apei, dupa cum este necesar
- Elementele din interiorul capului sunt realizate din ceramica de inalta calitate, rezistente la abraziune, coroziune si acumulare de impuritati (de exemplu, fier). Aceasta tehnologie asigura o etansare perfecta in interiorul controlerului si, prin urmare, functionarea lunga si fara probleme
- Carcasa de culoare albastru
- Diametrul racordului de apa 3/4"
- Presiune de lucru: 1,5-6,0 Ba
- Temperatura ambientala de lucru: 5 - 38°C
- Max. temperatura apei de alimentare: 38°C
- Timp de regenerare: 37 min
- Iesire pentru 10° dH - 1200 L
- Panza de rasina 4,0 L
- Rezervor de regenerare: 8 kg
- Fluxul maxim de apa: 5 L / min
- Consumul de sare de regenerare pe 1 ciclu: 0,5 kg



230442



230459

### DEDURIZATOR APA, SEMI-AUTOMAT

- Procesul semi-automat de regenerare a patului de rasina, folosind apa salina, este initiat manual
- Greutate: 8 kg

cod	V	W	mm	lei
230442	230	18	216x404x(H)504	1059,00

### DEDURIZATOR APA, AUTOMAT

- Procesul automat de regenerare a patului de rasina, folosind apa salina, este initiat automat.
- Cu ajutorul panoului de control se poate seta timpul de lucru, timpul de regenerare si cantitatea de apa care trebuie tratata.
- Blocarea automata impiedica accesul nedorit.
- Greutate: 7,7 kg.

cod	V	W	mm	lei
230459	230	18	214x417x(H)505	1289,00

## DEDURIZATOARE MANUALE

- Apa dura contine minerale dizolvate - compusi de calciu si magneziu, printre altele. Calciul si ionii de magneziu cauzeaza acumularea de calcar, riscante pentru obiectele si accesoriile care intra in contact cu apa sau aburul. Tratarea apei este un proces in care toti compusii de calciu si magneziu care determina duritatea apei sunt indepartati. Cand apa trece prin rasina catatonica, ionii de calciu si magneziu prezenti in aceasta, sunt retinuti de rasina. Atunci cand capacitatea de schimb ionic a rasinii se diminueaza, aceasta trebuie sa fie restaurata intr-un proces de regenerare adecvat cu utilizarea unei solutii de sare
- Agentul de decalcifiere a apei poate fi utilizat ori de cate ori

- este nevoie temperatura apei este sub 45 ° C, iar presiunea de intrare a apei nu depaseste 2 bari
- Regenerare: numai sare ionidizata
- Numai pentru apa potabila
- Potrivit pentru decalcifierea apei pentru aparatele de cafea, masinile de spalat vase si masinile pentru gheata.
- Datorita dimensiunilor mici, este perfect pentru baruri si restaurante
- Datorita componentelor de cea mai buna calitate utilizate, dispozitivul ramane in siguranta si functioneaza mai multi ani.
- Presiunea optima a apei de lucru: 1-2 bari



### DEDURIZATOR APA

- In timpul regenerarii balsamului, masina nu trebuie sa fie utilizata.
- Presiunea maxima / minima a apei: de la 1 la 8 bari.
- Flux nominal: 1000 L / h.
- Temperatura ambientala: de la 4°C la 35°C.
- temperatura apei de alimentare: de la 4°C la 25°C.
- Dimensiune conexiune: 3/8 .

cod	capacitate (20 °F / 30 °F / 40 °F)	litri	mm	lei
231210	1200/1000/900	8	ø185x(H)400	459,99
231227	2520/1680/1260	12	ø185x(H)500	519,99
231234	3360/2240/1680	16	ø185x(H)600	609,99

### COMPRESATE DE SARE PENTRU DEDURIZAREA APEI

- Confectionata din sare comprimata - compozitia materiei prime este doar clorura de sodiu NaCl.
- Sub forma de tablete - sarea se dizolva uniform
- Destinat pentru:
  - dedurizarea apei si prevenirea depunerilor de calcar,
  - dezinfectarea apei,
  - prelungirea duratei de functionare a aparatelor.
- Excelent pentru aparatele de gatit, spalatoriile auto, instalatiile de apa si multe alte scopuri. Poate fi utilizat impreuna cu toate tipurile de dedurizatoare de apa.

cod	greutate (kg)	lei
231265	25	64,99



231265



## CAPCANE INSECTE PENTRU BUCATARIILE SI RESTAURANTE



270080

### CAPCANA INSECTE CU PLACA ADEZIVA - ACOPERIRE 100 M<sup>2</sup>

- Potrivita pentru a fi folosita in bucatarie si in zone de servire a mesei
- Carcasa metalica ce include prinderea pe perete
- 2 lampi incasabile fluorescente de 15W
- Placa de adeziva la spate pentru prinderea insectelor
- Suprafata acoperire de aprox. 100 m<sup>2</sup>
- Placa adeziva inclusa

cod	V	W	mm	lei
270080	230	30	480x100x(H)285	<b>459,99</b>
270028	230	2x15	Lampa pentru capcanele de insecte. Set 2 lampi.	<b>179,99</b>

## CAPCANE INSECTE - UZ INTERIOR



270097

### CAPCANA DE INSECTE 300 M<sup>2</sup>

- Foloseste lumina LED UV-A durabila, durata medie de viata de 20.000 de ore.
- Corp rezistent la foc.
- ABS pentru siguranta ridicata.
- Insectele sunt electrocutate cu 4000 V.
- Tava de colectare detasabila, usor de curatat.
- Poate fi montat pe tavan cu lant sau poate fi folosit in picioare.

cod	V	W	mm	lei
270097	230	13	470x100x(H)265	<b>279,99</b>



270172

270165

270158



Lant inclus



Tava de colectare detasabila

### CAPCANA INSECTE - VOLTAJ MARE

- Pentru uz interior
- Constructie din aliaj de aluminiu special tratat si ABS rezistent la foc, pentru siguranta ridicata
- 2 lampi UV-A
- Insectele sunt electrocutate cu 2000 - 2500 V
- Tava de colectare extractibila, usor de curatat

cod	V	W	mm	lei
270158	230	26	379x103x(H)265	<b>179,99</b>
270165	230	40	515x104x(H)315	<b>246,99</b>
270172	230	45	655x90x(H)360	<b>283,99</b>



## CAPCANA INSECTE CU PLACA ADEZIVA - ACOPERIRE 120 M<sup>2</sup>

- Potrivita pentru a fi folosita in bucatarie si in zone de servire a mesei
- Carcasa ABS ignifuga, placa posterioara din metal, potrivita pentru prinderea pe perete
- 1 lampa incasabila fluorescenta de 36 W
- Placa de adeziv la spate pentru prinderea insectelor
- Lampa si placa de adeziv sunt usor de inlocuit
- Suprafata acoperire de aprox. 120 m<sup>2</sup>
- Placa adeziva inclusa - 390x270 mm

cod	V	W	mm	lei
270196	230	36	540x80x(H)281	<b>299,99</b>
270233	Placi adezive pentru capcanele de insecte. 10 coli.			<b>149,99</b>
270240	Lampa pentru capcanele de insecte			<b>84,99</b>



270196



## CAPCANE INSECTE - PENTRU EXTERIOR

### CAPCANA INSECTE - REZISTENTA LA APA

- Material din plastic ABS rezistent la foc pentru siguranta ridicata
- 2 lampi UV-A
- Insectele sunt electrocutate cu 2000 V
- Protectie la apa IPX4, poate fi folosita atat in interior cat si in exterior
- Tava de colectare detasabila, usor de curatat
- Lant agatare

cod	-	V	W	mm	lei
270066	100 m <sup>2</sup>	230	40	510x135x(H)305	<b>399,00</b>
270141	150 m <sup>2</sup>	230	45	680x140x(H)305	<b>374,99</b>
935286	Lampi de rezerva pentru capcana electronica insecte - 2 buc.				<b>59,99</b>



270066

Lant  
inclus

Tava de colectare detasabila

### LAMPI DE REZERVA PENTRU CAPCANA INSECTE

- Tub fluorescent UV-A

cod	pentru	V	W	mm	lei
934159	270158	230	8	300x15x(H)115	<b>32,99</b>
934166	270172 - 270141	230	20	602x24x(H)124	<b>29,99</b>



934159





691045

**CAPAC ROTUND**

cod	-	mm	lei
691045	pentru 691038	ø570x(H)35	<b>89,99</b>
691410	pentru 691403	ø505x(H)35	<b>69,99</b>



691052

**CAPAC ROTUND**

cod	-	mm	lei
691052	pentru 691038	ø570x(H)135	<b>129,99</b>
691427	pentru 691403	ø510x(H)120	<b>109,99</b>



691069

**FLIP OPEN COVER**

cod	-	mm	lei
691069	pentru 691038	ø580x(H)190	<b>169,99</b>
691434	pentru 691403	ø505x(H)190	<b>159,99</b>



691076

**CARUCIOR ROTATIV**

cod	-	mm	lei
691076	pentru 691038	ø455x(H)165	<b>169,99</b>
691441	pentru 691403	ø400x(H)165	<b>139,99</b>



691038

**CONTAINER ROTUND**

cod	litri	mm	lei
691038	120	ø550x(H)690	<b>329,99</b>
691403	80	ø490x(H)620	<b>269,99</b>



**AMER★BOX®**

PP  
polipropilene



691151

**CONTAINER CU PEDALA**

cod	litri	mm	lei
691151	68	490x410x(H)660	259,99
691168	87	500x410x(H)815	349,99



Mecanismul de prindere  
actionat cu piciorul  
mentine punga inchisa

S.S.  
stainless steel

**SUPPORT PUNGA GUNOI**

- Rama otel inoxidabil
- Mecanismul cu pedala tine punga inchisa
- 2 roti cu frana

cod	mm	lei
691021	420x580x(H)960	599,99



691021



## COSURI DE GUNOI SI SCRUMIERE



### COS DE GUNOI ROTUND CU PEDALA

- Constructie din otel inoxidabil
- Suprafata finisata
- Deschidere usoara si igienica
- Pedala anti-alunecare
- Sistem inovativ de blocare capac dupa deschidere
- Cos interior din polipropilena - flexibil, cu sistem fixare saci de gunoi

cod	litri	mm	lei
691311	5	ø210x(H)280	<b>74,99</b>
691335	20	ø300x(H)440	<b>149,99</b>
691342	30	ø300x(H)650	<b>197,99</b>



### COS DE GUNOI CU SCRUMIERA

- Constructie din otel inoxidabil
- Suprafata finisata
- Scrumiera detasabila, cu gratar, plasata deasupra cosului pentru o usoara curatare si golire a cosului
- Deschidere cos 135 mm
- Baza din cauciuc anti-alunecare pentru a asigura stabilitate si protectie pardoseala impotriva zgarieturilor

cod	litri	mm	lei
691380	15	ø200x(H)700	<b>197,99</b>
691397	33	ø240x(H)660	<b>387,99</b>

### COS DE GUNOI CU SCRUMIERA

- Constructie din otel inoxidabil
- Suprafata finisata
- Scrumiera detasabila, cu gratar, plasata deasupra cosului pentru o usoara curatare si golire a cosului
- Deschidere cos 135 mm
- Baza din cauciuc anti-alunecare pentru a asigura stabilitate si protectie pardoseala impotriva zgarieturilor

cod	litri	mm	lei
691380	15	ø200x(H)700	<b>197,99</b>
691397	33	ø240x(H)660	<b>387,99</b>



18/8  
stainless steel



### SCRUMIERA CU MONTARE PE PERETE

- Design foarte robust, usor de montat pe pereti si stalpi
- Usor de golit datorita fundului care poate fi deschis si inchis cu o cheie

cod	mm	lei
440216	ø75x(H)460	329,99



440216



18/8  
stainless steel



### SCRUMIERA TIP STALP

- Design foarte robust, poate fi montat pe podea cu prindere fixa sau fara prindere.
- Usor de golit, partea superioara poate fi deblocata cu o cheie.
- Baza este de ø170 mm, iar stalpul este de ø75 mm

cod	mm	lei
440223	ø170x(H)920	499,99



440223



# Mobilier HENDI din otel inoxidabil

## Asamblare usoara, independenta si rapida

### Ambalare compacta - costuri reduse de transport



430  
stainless steel

812525



813041

### RAFT 4 POLITE, PREGATIT PENTRU ASAMBLARE

- Confectionat din otel inoxidabil AISI 430
- Piele realizata din profile de 30x30 mm
- Sarcina maxima aproximativa pe raft - 70 kg/m<sup>2</sup>
- Picioare reglabile - 25 mm in sus sau 5 mm in jos

cod	mm	lei
812501	600x400x(H)1800	<b>1049,00</b>
812518	800x400x(H)1800	<b>1239,00</b>
812525	1000x400x(H)1800	<b>1329,00</b>
812532	1000x500x(H)1800	<b>1479,00</b>
812556	1000x600x(H)1800	<b>1499,00</b>
812549	1200x500x(H)1800	<b>1549,00</b>
812563	1200x600x(H)1800	<b>1679,00</b>

### RAFT CU 5 POLITE, AMBALAT IN CUTIE DE CARTON, PICIOARE PLIABILE

- Pentru uz profesional.
- Fabricat din otel inoxidabil AISI 430 de inalta calitate.
- Constructie robusta, fixe cu suruburi.
- 5 polite fixe.
- Picioare robuste cu profil de 30x30 mm.
- Capacitate de incarcare aproximativa a politelor: aprox. 70 kg/m<sup>2</sup>.
- Picioare reglabile: +25/-5 mm.

cod	mm	lei
813041	900x450x(H)1800	<b>1609,00</b>



## MESE DE LUCRU DIN OTEL INOXIDABIL KITCHEN LINE

- Pentru utilizare in catering profesional.
- Fabricat integral din otel inoxidabil AISI 430.
- Spatiu de lucru ranforsat cu o placa laminata si impermeabila pentru a consolida si a izola unitatea.
- Picioare fabricate din profile de 40x40 mm.
- Constructie cu surub care permite plierea, depozitarea si transportul mobilei.



- Acces la spatiul de lucru din toate partile.
- Capacitate maxima de incarcare a blatului si politei: aprox. 70 kg/m<sup>2</sup>
- Picioare reglabile: +25/-5 mm.



811276



811511

## MASA DE LUCRU HEAVY DUTY, ADANCIME 600 MM, KITCHEN LINE

- Capacitate maxima de incarcare a blatului: aprox. 70 kg/m<sup>2</sup>

cod	mm	lei
<b>FARA RAFT, ADANCIME 600 MM</b>		
816196	800x600x(H)850	809,99
811276	1000x600x(H)850	959,90
811283	1200x600x(H)850	999,99
811290	1400x600x(H)850	1099,00

## MASA DE LUCRU RANFORSATA CU POLITA INFERIOARA

- Capacitate maxima de incarcare a blatului si politei: aprox. 70 kg/m<sup>2</sup>

cod	mm	lei
<b>CU RAFT, ADANCIME 600 MM</b>		
816189	800x600x(H)850	979,99
811511	1000x600x(H)850	999,99
811528	1200x600x(H)850	1099,00
811535	1400x600x(H)850	1219,00
811542	1600x600x(H)850	1279,00
811559	1800x600x(H)850	1409,00

Blat de lucru ranforsat pentru o durabilitate mai mare in timp

### CU RAFT, ADANCIME 700 MM

815830	800x700x(H)850	1209,00
810705	1000x700x(H)850	1259,00
810712	1200x700x(H)850	1369,00
810729	1400x700x(H)850	1499,00
810736	1600x700x(H)850	1599,00
810743	1800x700x(H)850	1749,00



## TABELE DE LUCRU CU AUTO-ASAMBLARE KITCHEN LINE

- Pentru utilizare in catering profesional.
- Fabricat integral din otel inoxidabil AISI 430.
- Spatiu de lucru ranforsat cu o placa laminata si impermeabila pentru a consolida si a izola unitatea.
- Picioare fabricate din profile de 40x40 mm.
- Constructie cu surub care permite plierea, depozitarea si transportul mobilei.



- Acces la spatiul de lucru din toate partile.
- Capacitate maxima de incarcare a blatului si politei: aprox. 70 kg/m<sup>2</sup>
- Picioare reglabile: +25/-5 mm.



811245



811467

### MASA DE LUCRU CU REBORD, PREGATITA PENTRU ASAMBLARE

- Capacitate maxima de incarcare a blatului: aprox. 70 kg/m<sup>2</sup>

cod	mm	lei
<b>ADANCIME 600 MM</b>		
811238	800x600x(H)850	<b>749,99</b>
811245	1000x600x(H)850	<b>959,99</b>
811252	1200x600x(H)850	<b>999,00</b>
811269	1400x600x(H)850	<b>1099,00</b>
<b>ADANCIME 700 MM</b>		
812679	1000x700x(H)850	<b>999,00</b>
812686	1200x700x(H)850	<b>1099,00</b>
812693	1400x700x(H)850	<b>1199,00</b>

### MASA DE LUCRU CU REBORD SI POLITA, PREGATITA PENTRU ASAMBLARE

- Capacitate maxima de incarcare a blatului si politei: aprox. 70 kg/m<sup>2</sup>

cod	mm	lei
<b>ADANCIME 600 MM</b>		
811450	800x600x(H)850	<b>999,00</b>
811467	1000x600x(H)850	<b>1099,00</b>
811474	1200x600x(H)850	<b>1179,00</b>
811481	1400x600x(H)850	<b>1329,00</b>
811498	1600x600x(H)850	<b>1399,00</b>
811504	1800x600x(H)850	<b>1499,00</b>
<b>ADANCIME 700 MM</b>		
812716	800x700x(H)850	<b>1299,00</b>
812723	1000x700x(H)850	<b>1399,00</b>
812730	1200x700x(H)850	<b>1449,00</b>
812747	1400x700x(H)850	<b>1499,00</b>
812754	1600x700x(H)850	<b>1599,00</b>
812761	1800x700x(H)850	<b>1629,00</b>



## SPALATOARE CU 1 CUVA DIN OTEL INOXIDABIL KITCHEN LINE

430  
stainless steel



- Bazinele chiuvetelor sunt presate dintr-o singura bucata de otel inoxidabil caracterizata de rezistenta ridicata la acizi alimentari si substante chimice
- Volumul chiuvetei sudat perfect in blatul de lucru
- Dimensiunile chiuvetei: 400x400x(H)250 mm
- Comparativ cu sisteme de prindere standard: Ø50 mm
- Deschidere Ø30 mm
- Computer cu adancitura de 10 mm pentru a impiedica apa sa iasa
- Fetusa impletita
- Feetita confectionata din profiluri de 40x40 mm
- Inchiderea 40 mm previne colorarea peretilor
- Picioare picioare deplasate din perete cu 50 mm pentru a asigura montarea usoara in perete
- Picioare reglabile - 25 mm in sus sau 5 mm in jos



811573



811870

## SPALATOR CU 1 CUVA DIN OTEL INOXIDABIL

- Capacitate maxima de incarcare a blatului: aprox. 70 kg/m<sup>2</sup>

cod	mm	amplasarea cuvei	lei
<b>ADANCIME 600 MM</b>			
811849	600x600x(H)850	mijloc	1229,00
811573	1000x600x(H)850	dreapta	1619,00
812648	1000x600x(H)850	stanga	1619,00

<b>ADANCIME 700 MM</b>			
cod	mm	amplasarea cuvei	lei
812877	600x700x(H)850	mijloc	1499,00
812884	1000x700x(H)850	dreapta	1799,00

## SPALATOR CU 1 CUVA CU POLITA INFERIOARA DIN OTEL INOXIDABIL

- Capacitate maxima de incarcare a blatului si politei: aprox. 70 kg/m<sup>2</sup>

cod	mm	amplasarea cuvei	lei
<b>ADANCIME 600 MM</b>			
811856	600x600x(H)850	mijloc	1399,00
811863	800x600x(H)850	dreapta	1539,00
812495	800x600x(H)850	stanga	1539,00
811870	1000x600x(H)850	dreapta	1749,00
812631	1000x600x(H)850	stanga	1749,00

<b>ADANCIME 700 MM</b>			
cod	mm	amplasarea cuvei	lei
812938	1000x700x(H)850	dreapta	1799,00
812945	1000x700x(H)850	stanga	1799,00

Rebordul de 10 mm de pe partea superioara impiedica scurgerea apei



## TABELE PENTRU CHIUVEVE – INSURUBATE KITCHEN LINE

- Bolurile chiuvetelor sunt presate dintr-o singura bucata de otel inoxidabil caracterizata de rezistenta ridicata la acizi alimentari si substante chimice
- Volumul chiuvetei sudat perfect in blatul de lucru
- Dimensiunile chiuvetei: 400x400x(H)250 mm
- Comparativ cu sisteme de prindere standard: Ø50 mm
- Deschidere Ø30 mm
- Computer cu adancitura de 10 mm pentru a impiedica apa sa iasa

430  
stainless steel



- Fetusa impletita
- Feetita confectionata din profiluri de 40x40 mm
- Inchiderea 40 mm previne colorarea peretilor
- Picioare picioare deplasate din perete cu 50 mm pentru a asigura montarea usoara in perete
- Picioare reglabile – 25 mm in sus sau 5 mm in jos



811580



811887

### SPALATOR CU 2 CUVE, PREGATIT PENTRU ASAMBLARE

- Capacitate maxima de incarcare a blatului: aprox. 70 kg/m<sup>2</sup>

cod	mm	amplasarea cuvei	lei
<b>ADANCIME 600 MM</b>			
811580	1000x600x(H)850	mijloc	1899,00

cod	mm	amplasarea cuvei	lei
<b>ADANCIME 700 MM</b>			
812952	1000x700x(H)850	mijloc	2099,00

### SPALATOR CU 2 CUVE CU POLITA INFERIOARA, PREGATIT PENTRU ASAMBLARE

- Capacitate maxima de incarcare a blatului si politei: aprox. 70 kg/m<sup>2</sup>

cod	mm	amplasarea cuvei	lei
<b>ADANCIME 600 MM</b>			
811887	1000x600x(H)850	mijloc	1999,00

cod	mm	amplasarea cuvei	lei
<b>ADANCIME 700 MM</b>			
812969	1000x700x(H)850	mijloc	2299,00



811818

430  
stainless steel



### SPALATOR

- Cua din otel inoxidabil AISI 304.
- Dimensiuni cua: 350x250x(H)100 mm.
- Gaura ø35 mm pentru HENDI 970522.
- Iesire ø52 mm adaptata la sifoane standard.

cod	mm	lei
811818	400x295x(H)145	559,99

## MESE DE LUCRU DIN OTEL INOXIDABIL BUDGET LINE

- Constructie robusta realizata in intregime din otel inoxidabil AISI 430.
- Blat ranforsat cu profil longitudinal.
- Picioare din profile de 40x40 mm.
- Structura cu suruburi permite plierea, depozitarea si transportul echipamentului.



- Un echipament practic - blatul poate fi accesat din toate partile mesei.
- Articoul este rezistent, poate fi folosit intens.
- Pe blatul de lucru se pot pune si echipamente de mici dimensiuni.
- Sarcina maxima aproximativa pe blat si pe polita inferioara: 70 kg/m<sup>2</sup>.
- Picioare reglabile: +25/-5 mm.



811276



811511

## MASA DE LUCRU BUDGET LINE, ADANCIME 600 MM

cod	mm	lei
817056	600x600x(H)850	719,99
817063	800x600x(H)850	749,99
817070	1000x600x(H)850	799,99
817087	1200x600x(H)850	859,99

## MASA DE LUCRU CU POLITA INFERIOARA BUDGET LINE, ADANCIME 600 MM

cod	mm	lei
817094	600x600x(H)850	949,99
817100	800x600x(H)850	979,99
817162	1000x600x(H)850	999,99
817179	1200x600x(H)850	1099,00



811245



811467

## MASA DE LUCRU CU REBORD BUDGET LINE, ADANCIME 600 MM

cod	mm	lei
817186	600x600x(H)850	749,99
817193	800x600x(H)850	799,99
817209	1000x600x(H)850	849,99
817216	1200x600x(H)850	879,99

## MASA DE LUCRU CU REBORD SI POLITA INFERIOARA BUDGET LINE, ADANCIME 600 MM

cod	mm	lei
817223	600x600x(H)850	899,99
817261	800x600x(H)850	999,99
817278	1000x600x(H)850	1049,00
817285	1200x600x(H)850	1099,00

## SPALATOR CU 1 CUVA BUDGET LINE DIN OTEL INOXIDABIL

- Structura din oțel inoxidabil.
- Cuvă spalator presată si fabricată dintr-o singură foaie de oțel inoxidabil.
- Rezistență ridicată la acizii alimentari și chimicale.
- Gofrare standard în partea inferioară pentru sifon: Ø50 mm
- Orificiu pentru robinet Ø30 mm
- Rebordul de 10 mm pe partea de sus previne scurgerea apei

430  
stainless steel



- Structura oțel inoxidabil
- Picioare din profile de 40x40 mm
- Rebordul din spatele spalatorului este de 40 mm și previne murdărirea peretelui
- Picioarele din spate ale mesei setate la 50 mm de perete pentru ușurința în utilizare și montaj la perete
- Picioare reglabile - 25 mm în sus sau 5 mm în jos



816790



817025

## SPALATOR CU 1 CUVA BUDGET LINE DIN OTEL INOXIDABIL, ADANCIME 600 MM

cod	mm	amplasarea cuvei	lei
816752	600x600x(H)850	mijloc	1249,00
816769	800x600x(H)850	dreapta	1299,00
816776	800x600x(H)850	stanga	1299,00
816783	1000x600x(H)850	dreapta	1349,00
816790	1000x600x(H)850	stanga	1349,00

## SPALATOR CU 1 CUVA BUDGET LINE CU POLITA INFERIOARA DIN OTEL INOXIDABIL, ADANCIME 600 MM

cod	mm	amplasarea cuvei	lei
816806	600x600x(H)850	mijloc	1399,00
816998	800x600x(H)850	dreapta	1549,00
817001	800x600x(H)850	stanga	1549,00
817018	1000x600x(H)850	dreapta	1599,00
817025	1000x600x(H)850	stanga	1599,00



817049



817032

## SPALATOR CU 2 CUVE BUDGET LINE DIN OTEL INOXIDABIL, ADANCIME 600 MM

cod	mm	lei
817049	1000x600x(H)850	1629,00

## SPALATOR CU 1 CUVA BUDGET LINE CU POLITA INFERIOARA DIN OTEL INOXIDABIL, ADANCIME 600 MM

cod	mm	lei
817032	1000x600x(H)850	1999,00



## MASA PENTRU CHIUVEȚA – SUDATA, 2 CHIUVEȚE

- Bazele chiuvețelor sunt presate dintr-o singură bucată de oțel inoxidabil caracterizată de rezistență ridicată la acizii alimentari și substanțe chimice
- Bolul chiuveței sudat perfect în blatul de lucru
- Dimensiunile chiuveței: 400x400x(H)250 mm
- Comparativ cu sisteme de prindere standard: Ø50 mm
- Deschidere prin atingere Ø30 mm
- Computer cu adăugarea de 10 mm pentru a împiedica apa să iasă
- Feetusa sudată
- Realizată din profiluri de 40x40 mm închiderea de 40 mm previne colorarea peretilor
- Picioare picioare deplasate din perete cu 50 mm pentru a asigura montarea ușoară pe perete
- Picioare reglabile – 25 mm în sus sau 5 mm în jos



815007

430  
stainless steel

## DULAPURI PENTRU MASA DE LUCRU DE PERETE – SUDATE

- Fabricat din oțel inoxidabil AISI 430
- Sudate pentru durabilitate și stabilitate ridicată
- Blat inferior cu placă laminată impermeabilă care întărește și izolează fonic articolul
- Sarcină maximă aproximativă per blat – 70 kg/m<sup>2</sup>
- Spatarul de 40 mm previne patarea peretilor
- Maneralele ușilor din plastic
- Corpul dulapului a fost mutat de pe perete cu 100 mm pentru a asigura montarea ușoară pe perete
- Înălțimea picioarelor: 160 mm, picioare reglabile – 25 mm în sus sau 5 mm în jos
- Raft detașabil, nedepășabil



811658

430  
stainless steel

## SPALATOR DIN OTEL INOXIDABIL - SUDATA, 2 CUVE, ADANCIME:600 MM

- Sarcină maximă aproximativă pe blatul de lucru – 70 kg/m<sup>2</sup>.

cod	mm	lei
815007	1000x600x(H)850	2119,00

## CABINET MONTAT PE PERETE SUDAT CU USI GLISANTE

- Fabricat din oțel inoxidabil durabil (AISI 430).
- Prevăzute cu usi glisante, acces foarte eficient și sigur la dulap.
- Cu manere de plastic confortabile pentru deschidere/închidere și curățare ușoare.
- Suprafața internă netedă ușurează curățarea.
- Capacitate maximă de încărcare prin răspândire pe raft: 70 kg/m<sup>2</sup>.
- Sudat pentru durabilitate și stabilitate ridicată.
- Livrat cu suporturi speciale pentru montaj pe perete.

cod	mm	lei
<b>ADANCIME 300 MM</b>		
814154	800x300x(H)600	1299,00
811207	1000x300x(H)600	1529,00
<b>ADANCIME 400 MM</b>		
814178	800x400x(H)600	1569,00
814185	1000x400x(H)600	1699,00
811214	1200x400x(H)600	1699,00

## MASA DULAP CU USI GLISANTE, SUDATA

- Dulap închis cu usi glisante

cod	mm	lei
811641	800x600x(H)850	2199,00
811658	1000x600x(H)850	2299,00
811665	1200x600x(H)850	2499,00
811672	1400x600x(H)850	2799,00
811689	1600x600x(H)850	2879,00



811207

## MASA PENTRU CHIUVEȚA CU DULAP – SUDATA

- Bolurile chiuvetelor sunt presate dintr-o singura bucată de oțel inoxidabil caracterizată prin rezistență ridicată la acizi și substanțe chimice alimentare.
- Bolul chiuvetei este sudat perfect pe blatul de lucru.
- Dimensiuni chiuveta: 400x400x(H)250 mm.
- Scurgere compatibilă cu capcanele standard: Ø50 mm.
- Deschidere tarod Ø 30 mm.
- Suprafața de lucru cu adâncitură de 10 mm pentru a preveni scurgerea apei.

- Sudat pentru durabilitate și stabilitate ridicată.
- Sarcină maximă aproximativă pe blatul de lucru – 70 kg/m<sup>2</sup>, 40 mm pot împiedica patarea peretilor.
- Manere de usă din plastic.
- Corpul dulapului s-a deplasat de pe perete cu 100 mm, fără perete posterior, pentru a asigura accesul la racordul de apă și canalizare.
- Înălțimea picioarelor: 160 mm, picioare reglabile – 25 mm în sus sau 5 mm în jos.



430  
stainless steel



430  
stainless steel

## MASA PENTRU CHIUVEȚE CU DULAP CU BALAMALE PENTRU USĂ – SUDATA, 1 BAZIN PENTRU CHIUVEȚA

- Dulap cu balamale al ușii, balamaua din stânga.
- Încuietori magnetice inovatoare.

cod	mm	lei
<b>ADÂNCIME 600 MM</b>		
813492	500x600x(H)850	2049,00
813522	600x600x(H)850	2199,00

### ADÂNCIME 700 MM

813539	500x700x(H)850	2099,00
813546	600x700x(H)850	2399,00

## DOUA MESE DE CHIUVEȚA CU DULAP CU USĂ GLISANTĂ – SUDATE.

- Dulapul ușii culisante.

cod	mm	lei
813690	1000x600x(H)850	3399,00

## EXTREME STEEL DETERGENT PROFESIONAL PENTRU OȚEL INOXIDABIL - 1L

cod	litri	lei
979761	1	35,99



979761



304  
stainless steel430  
stainless steel

813423



816707

### SPALATOR CU 1 CUVA MARE

- Sudata in bazin, fabricata din otel inoxidabil AISI 304, pentru rezistenta ridicata la acizi si substante chimice alimentare.
- Zona imprimata in relief - scapati spre capcana, in forma de ptic.
- Evacuare compatibila cu capcanele standard:  $\phi$ 50 mm.40 mm pentru a preveni scurgerea apei.
- Cadru si corp fabricate din standard AISI 430, dimensiuni 40x40 mm.
- Capac frontal pentru masa - fabricat din otel AISI 430.
- Sudat pentru durabilitate si stabilitate ridicate.
- Picioare reglabile: +25/-5 mm.
- Deschidere conica:  $\phi$ 30 mm.

cod	mm	dimensiunea cuva [mm]	lei
<b>SPALATOR CU 1 CUVA MARE - SUDATA, ADANCIME: 600 MM, CUVA: 300 MM</b>			
813294	600x600x(H)850	486x443x(H)300	1299,00
811825	800x600x(H)850	686x443x(H)300	1499,00
811832	1000x600x(H)850	886x443x(H)300	1649,00

### SPALATOR CU 1 CUVA MARE - SUDATA, ADANCIME: 600 MM, CUVA: 400 MM

813423	1000x600x(H)850	886x443x(H)400	2099,00
813430	1200x600x(H)850	886x443x(H)400	2259,00

### SPALATOR CU 1 CUVA MARE - SUDATA, ADANCIME: 700 MM, CUVA: 300 MM

812853	800x700x(H)850	686x540x(H)300	1749,00
812860	1000x700x(H)850	886x540x(H)300	1799,00

### SPALATOR CU 2 CUVE MARI - SUDATE, ADANCIME: 600 MM, CUVA: 300 MM

813485	1200x600x(H)850	2x 541x443x(H)300	2799,00
--------	-----------------	-------------------	---------

### SPALATOR CU 1 CUVA MARE BUDGET LINE

- Constructie robusta realizata in intregime din otel inoxidabil.
- Cuva din AISI 304.
- Cadru si corp din otel inoxidabil AISI 430.
- Inaltimea cuvei: 300 mm.
- Sifon scurgere:  $\phi$ 50 mm.
- O deschidere speciala, situata central, pentru instalarea unui robinet de  $\phi$ 30 mm.
- Rebord de 40 mm pe o parte a mesei protejeaza peretii de pete si umezeala.
- Dista de la rebord la cuva: 100 mm.
- Picioare din profile inox AISI 430 de 40x40 mm.
- Cadru sudat.
- Picioare reglabile: +25/-5 mm.
- Versiune fara inchiderile exterioare frontale si laterale.

cod	mm	lei
816707	800x600x(H)850	1499,00
816714	1000x600x(H)850	1599,00

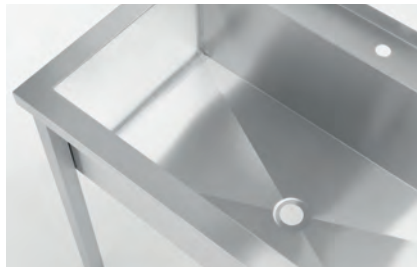



811009



### SPALATOR CU 1 CUVA MARE BUDGET LINE, ADANCIME: 600 MM

- Bazin fabricat integral din otel inoxidabil AISI 304.
- Inaltime bazin: 300 mm.
- Scurgere compatibila cu capcane standard:  $\varnothing$ 50 mm.
- Zona imprimata in relief - curgerea apei spre sifon, in forma de plic.
- O deschidere speciala, amplasata central, pentru instalarea unui tarod cu  $\varnothing$  30 mm.
- Un rebord de 40 mm pe o parte a mesei protejeaza peretii de pete si umezeala.
- Picioare confectionate din profiluri din otel inoxidabil AISI 430 40x40 mm.
- Distanta de la jocul de intoarcere la bazin: 100 mm.
- Structura insurubata permite plierea, depozitarea si transportul piesei de echipament.
- Picioare reglabile: +25/-5 mm.
- Versiuni fara capace exterioare fata si laterala.
- Livrarea ambalajului plat pentru auto-asamblare (sistem de blocare inclus).

cod	mm	lei
811009	800x600x(H)850	1549,00
811023	1000x600x(H)850	1699,00



979761

### EXTREME STEEL DETERGENT PROFESIONAL PENTRU OTEL INOXIDABIL - 1L

cod	litri	lei
979761	1	35,99





811719

### RAFT DE PERETE SIMPLU REGLABIL

- Fabricat din otel inoxidabil AISI 430
- Constructie sudata care asigura rezistenta si stabilitate ridicata
- Sarcina maxima admisa la raft este de 25 kg/m<sup>2</sup>
- Rebord la perete de 30 mm protejeaza marfurile impotriva caderii
- Posibilitatea de demontare si suprafata neteda a raftului il fac usor de spalat

cod	mm	lei
811719	800x300x(H)600	299,99
811788	1000x300x(H)600	339,99
811795	1200x300x(H)600	369,99
811801	1400x300x(H)600	379,99



811726

### RAFT DE PERETE DUBLU REGLABIL

- Fabricat din otel inoxidabil AISI 430
- Constructie sudata care asigura rezistenta si stabilitate ridicata
- Sarcina maxima admisa la raft este de 25 kg/m<sup>2</sup>
- Rebord la perete de 30 mm protejeaza marfurile impotriva caderii
- Posibilitatea de demontare si suprafata neteda a raftului il fac usor de spalat

cod	mm	lei
<b>ADANCIME 300 MM</b>		
811771	800x300x(H)600	602,99
811726	1000x300x(H)600	658,99
811733	1200x300x(H)600	799,99
811740	1400x300x(H)600	759,99
<b>ADANCIME 400 MM</b>		
816592	1000x400x(H)600	899,99



812044

### STATIV PENTRU VASE

- Fabricat integral din otel inoxidabil AISI 430 de calitate superioara.
- Constructia sudata robusta garanteaza stabilitatea si durabilitatea ridicata a suportului.
- Suprafata de lucru intarita cu un profil din otel.
- Picioare fabricate din profiluri de 40x40 mm.
- Picioare reglabile: +25/-5 mm.
- Sarcina maxima aproximativa per blat de lucru (cand este distribuita uniform): 100 kg/m<sup>2</sup>.

cod	mm	lei
812044	550x550x(H)450	659,99



816486

### RAFT DE PERETE

- Fabricat din otel inoxidabil AISI 430.
- Sudat pentru durabilitate si stabilitate ridicate.
- Sarcina maxima aproximativa pe raft - 25 kg/m<sup>2</sup>, 30 mm joc de intoarcere previne caderea bunurilor.
- Livrat cu doua suporturi din otel pentru montare aparenta.

cod	mm	lei
816486	800x300x(H)250	329,99
816493	1000x300x(H)250	369,99
816509	1200x300x(H)250	389,99
816516	1400x300x(H)250	429,99

## TABLOURI CU USI GLISANTE, CU TRECERE

- Fabricat din otel inoxidabil AISI 430
- Incarcarea maxima admisa a raftului este de 70 kg/m<sup>2</sup>
- Manere din plastic
- Picioare reglabile - 25 mm in sus sau 5 mm

430  
stainless steel



811108



812402

### DULAP DE TRECERE CU USI GLISANTE, PREGATIT PENTRU ASAMBLARE

- Fabricat din otel inoxidabil AISI 430, auto-asamblare, 2 rafturi detasabile, nereglabile 2 rafturi fixe (raftul inferior si mijloc).
- 8 usi glisante pe rulmenti.
- Maner vertical al usii
- Picioare reglabile pe profil patrat

cod	mm	lei
811634	800x500x(H)1800	4999,00
811108	1000x600x(H)1800	5309,00

### DULAP DE TRECERE CU USI GLISANTE, PREGATIT PENTRU ASAMBLARE

- Fabricat din otel inoxidabil AISI 430, auto-asamblare, 2 rafturi detasabile, nereglabile 2 rafturi fixe (raftul inferior si mijloc).
- 4 usi glisante pe rulmenti.
- Maner vertical al usii.
- Picioare reglabile pe profil patrat.

cod	mm	lei
812402	800x700x(H)1800	4499,00

### HOTA TIP SNACK - DE PERETE

- Indispensabil in fiecare bucatarie pentru captarea si degajarea caldurii, aburului si a poluantilor de pe dispozitivele de incalzire
- Fabricat in intregime din otel inoxidabil AISI 430 de inalta calitate
- Cu priza pentru conectarea la ventilatie: 1x ø200 mm
- Un set de filtre labirint, realizate din otel inoxidabil, astfel incat sa poata fi spalate in masini de spalat vase
- Depunerile si grasimile de pe filtrele labirintului curg pana la un jgheab special
- Cu sau fara iluminare cu LED in functie de model
- Sistem de gauri si curele care permit asamblarea
- Hota trebuie conectata la un ventilator sau la un sistem de ventilatie din cladire

430  
stainless steel

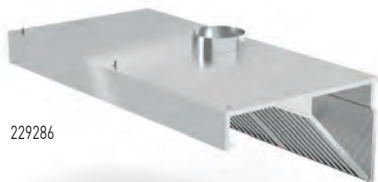

229286

cod	mm	lei	
229286	-	1000x700x(H)450	2359,00
229293	-	1200x700x(H)450	2599,00
229309	DA	1000x700x(H)450	2799,00
229316	DA	1200x700x(H)450	2899,00





23766

### MASA DE IESIRE PENTRU MASINA DE SPALAT VASE

- Fabricat integral din otel inoxidabil AISI 430 de calitate superioara.
- Suprafata de lucru este intarita din partea de jos.
- Profilurile de pe marginile mai lungi ale blatului de lucru fixeaza ferm suportul masinii de spalat vase si servesc drept ghidaje pentru deplasarea usoara pe masa.
- Concept pentru suporturi pentru masina de spalat vase de 500x500 mm.
- Picioare fabricate din profilurile de 40x40 mm.
- Incuietoarea conecteaza cu usurinta blatul de lucru la masina de spalat vase a hoteli, facilitand transportul fara probleme al suporturilor pentru masina de spalat vase (specificati modelul masinii de spalat vase atunci cand plasati o comanda).
- Model versatil - este posibila conectarea la masina de spalat vase pe partea din fata, stanga sau dreapta - trebuie doar sa intoarceti masa de descarcare!
- Picioare reglabile: +25/-5 mm permit inclinarea blatului de lucru spre masina de spalat vase - aceasta pozitie a mesei cauzeaza scurgerea apei inapoi in masina de spalat vase.
- Sarcina maxima aproximativa per blat de lucru (cand este distribuita uniform): 70 kg/m<sup>2</sup>.

cod	mm	lei
23766	1100x600x(H)850	1599,00



811924

### MASA INTRARE PENTRU MASINA DE SPALAT VASE, PREGATITA PENTRU ASAMBLARE

- Cuva si blatul de lucru din otel inoxidabil rezistent la acid AISI 304.
- Blatul mesei cu un cos de coborare si latime de 510 mm pentru masini de spalat vase.
- Are cartile pentru masini de spalat vase (la comanda, specificati modelul masinii de spalat vase).
- Alegerea versiunii din dreapta sau din stanga.
- Chiuveata 400x400x(H)250 mm.
- Picioare reglabile pe inaltime din profil patrat.
- Cu o margine de 40 mm - va permite sa mentineti igiena.
- Blatul mesei este intarit cu un profil din otel.
- Iesire ø52 mm adaptata la sifoane standard.

cod	tip	mm	lei
811917	Dreapta	1000x600x(H)850	1749,00
811924	Stanga	1000x600x(H)850	1749,00



815786

### MASA MOBILA CU RAFT - INSURUBATA

- Fabricat din otel inoxidabil AISI 430.
- Picioare confectionate din profilurile de 40x40 mm.
- Suprafata de lucru este umpluta. Antifonata cu o placa de lucru laminata si impermeabila, care reduce zgomotele din timpul procesului de gatire.
- Raft din otel montat la 200 mm, nereglabil.
- Incarcatura maxima aproximativa per blat de lucru si per raft - 70 kg/m<sup>2</sup>.
- Suprafata de lucru fara joc de intoarcere permite utilizatorului sa utilizeze masa indiferent de pozitia in care se afla.
- 4 roti pivotante cu zgomot scazut Ø125 mm, dintre care doua sunt echipate cu frana

cod	mm	lei
815793	1200x600x(H)850	1759,00

# EXTREME

**PROFESSIONAL**



## EXTREME STEEL DETERGENT PROFESIONAL PENTRU OTEL INOXIDABIL - 1L

- Potrivit pentru spalarea si intretinerea suprafetelor din otel inoxidabil.
- Elimina eficient murdaria, grasimea, amprentele si praful.
- Ofera stralucire si lasa un strat protector care impiedica depunerile.

cod	litri	lei
979761	1	35,99



979761





### GREEN FIRE

- Mai puțin sensibil la vânt datorită îmbunătățirii alimentării cu aer
- Usor de curățat datorită arzătoarelor detașabile și a tavii de scurgere GN 2/1 detașabile
- Arzătoarele îmbunătățite garantează încălzirea suprafeței de lucru în proporție de 90%
- Partile tehnice montate la loc ferit
- Ardere foarte curată, emisii scăzute de CO<sub>2</sub>
- Picioare detașabile



149508

### GRILL BARBECUE GREEN FIRE CU 2 ARZATOARE

- Echiptat cu panou anti-vânt
- Grilaj suspendat pentru păstrare la cald alimente
- Furtun gaz cu conectare ușoară, furtunul și regulatorul se atasează recipientului de gaz - portabilitate îmbunătățită

cod		kW[HS]	mm	lei
149621	2 gratare barbecue GN 1/1 din oțel inoxidabil	11.6	740x612x(H)825	3499,00
149508	Tava emailată GN 1/1 din fontă și grilaj	11.6	740x615x(H)825	3699,00



149591

### GRILL BARBECUE GREEN FIRE CU 3 ARZATOARE

- Tava emailată de fontă și 2 grilaje GN 1/1 incluse
- Echiptat cu panou anti-vânt
- Grilaj suspendat pentru păstrare la cald alimente
- Furtun gaz cu conectare ușoară, furtunul și regulatorul se atasează recipientului de gaz - portabilitate îmbunătățită

cod	kW[HS]	mm	lei
149591	17.4	1078x612x(H)825	5789,00





149614

### GRILL BARBECUE GREEN FIRE CU 4 ARZATOARE

- 2 tavi emailate din fonta si grilaje GN 1/1 incluse
- Echipat cu panou anti-vent
- Grilaj suspendat pentru pastrare la cald alimente
- Furtun gaz cu conectare usoara. Furtunul si regulatorul se ataseaza recipientului de gaz - portabilitate imbunatatita

cod	-	kW[HS]	mm	lei
149614	pe suport cu roti	22	1400x612x(H)825	7299,00



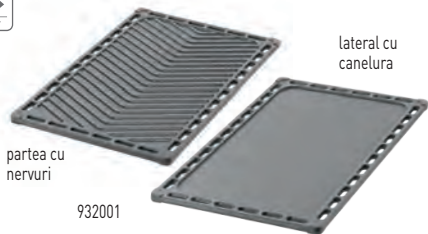

partea cu nervuri

932001

lateral cu canelura

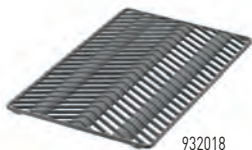

932018

### GRATAR FONTA

- Potrivit pentru toate gratarele Green Fire Profi Line.
- Ambele fete sunt usor de folosit, o parte neteda, o parte striata.

cod	GN	mm	lei
932001	GN 1/1	325x530	229,99

### GRATAR FONTA STRIAT

- Potrivit pentru toate gratarele Green Fire Profi Line

cod	GN	mm	lei
932018	GN 1/1	325x530	199,99



939949

939956

### DIFUZOR FLACARA

- Pozitionati difuzorul pentru flacara deasupra arzatorului pentru ca grasimea sa nu curga direct pe arzator
- Difuzor pentru flacara din otel inoxidabil
- Potrivit pentru toate aparatele barbecue Green Fire Profi Line

cod	mm	lei
939956	650x530	132,99



170045



170328

170120



### TEPUSE FRIGARUI - 24 BUCATI

cod	ambalat pe	mm	lei
170045	24	(L)210	29,99

### TEPUSE FRIGARUI - 6 BUCATI

cod	ambalat pe	mm	lei
170120	6	(L)250	19,99
170328	6	(L)350	26,99





152706

152805



152904

### ROCA VULCANICA - FINA

- Potrivita pentru diferite tipuri de gratare pe gaz
- Bucati relativ mici

cod	-	greutate (kg)	lei
152706	cutie	3	<b>36,99</b>

### ROCA VULCANICA - MARE

- Potrivita pentru diferite tipuri de gratare pe gaz.
- Bucati relativ mari.

cod	-	greutate (kg)	lei
152904	sac	9	<b>59,99</b>
152805	cutie	5	<b>49,99</b>

### GRATARE PE GAZ GRILL-MASTER PRO

- Disponibil in 2 versiuni: autonom sau de banc.
- 2 arzatoare independente pe gaz cu aprindere piezo.
- 2 difuzoare de flacara fabricate din otel inoxidabil AISI 430.
- 2 grile din otel cromat cu dimensiuni de 470x320 mm.
- O tava de picurare mare care ajuta, de asemenea, la retinerea caldurii in interiorul carcasei.
- Supape din cupru cu sistem automat de inchidere a gazului - opreste fluxul de gaz la stingerea flacarii.
- Furtun de gaz cu regulator de presiune inclus.
- Adekvat pentru gaz propan si butan.

### FRIPTURA-MASTER PRO NEGRU

- Carcasa fabricata din otel inoxidabil AISI 430 finisata cu email negru.
- Partea frontala si cele 4 picioare fabricate din otel inoxidabil AISI 201 finisate cu un strat de pudra neagra.

cod	KW[HS]	mm	lei
148822	11.6	790x560x(H)900	<b>1869,00</b>



**NOU**

18/10  
stainless steel

Cr  
chrome plated

outdoor



148822

## BAKE- & GRILL-MASTER



154601



### BAKE-MASTER MINI

- Cadru din otel inoxidabil 18/0
- Cu tava emailata
- Dimensiunile interioare ale tigaii sunt 290x480x(H)55 mm
- Aprindere electronica si termocuplu
- Furtun de gaz si regulator de presiune incluse
- Poate fi folosit cu butelie de propan sau butan
- Consum 0,215 m<sup>3</sup>/h

cod	kW[HS]	mm	lei
154601	5.8	340x540x(H)300	699,99

154618



### BAKE-MASTER MAXI

- Cadru din otel inoxidabil 18/0
- Cu tava emailata
- Dimensiunile interioare ale tigaii sunt 590x480x(H)55 mm
- Aprindere electronica si termocuplu
- Furtun de gaz si regulator de presiune incluse
- Poate fi folosit cu butelie de propan sau butan
- Consum 0,430 m<sup>3</sup>/h

cod	kW[HS]	mm	lei
154618	11.6	650x540x(H)300	1099,00

154700



Tigaie emailata inclusa

### GRILL-MASTER MINI

- Cadru din otel inoxidabil 18/0
- Cu gratar cromat si tigaie emailata
- Dimensiunile interioare ale tigaii sunt 290x480x(H)55 mm
- Aprindere electronica si termocuplu
- Furtun de gaz si regulator de presiune incluse
- Poate fi folosit cu butelie de propan sau butan
- Consum 0,215 m<sup>3</sup>/h

cod	kW[HS]	mm	lei
154700	5.8	340x540x(H)840	899,99

154717



### GRILL-MASTER MAXI

- Cadru din otel inoxidabil 18/0
- Cu gratar cromat si tigaie emailata
- Dimensiunile interioare ale tigaii sunt 590x480x(H)55 mm
- Aprindere electronica si termocuplu
- Furtun de gaz si regulator de presiune incluse
- Poate fi folosit cu butelie de propan sau butan
- Consum 0,430 m<sup>3</sup>/h

cod	kW[HS]	mm	lei
154717	11.6	650x540x(H)840	1399,00





### ROAST-MASTER MAXI

- Cu gratar cromat si difuzor flacara
- Cadru si difuzor din otel inoxidabil 18/0
- Aprindere electronica si termocuplu
- Furtun de gaz si regulator de presiune incluse
- Poate fi folosit cu butelie de propan sau butan
- Consum 0,430 m<sup>3</sup>/h

cod	kW(H/S)	mm	lei
154878	11	650x540x(H)840	1049,00

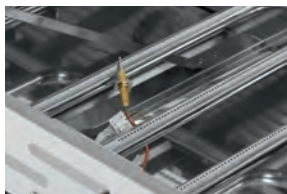
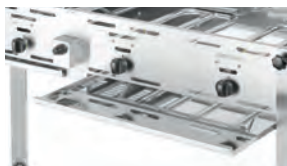

### GRILL-MASTER QUATTRO

- Cadru in intregime din otel inoxidabil si 2 tavi de picurare
- Potrivit pentru propan si butan gaz, echipat cu 4 arzatoare ce pot fi reglate independent
- Contine 2 grilaje nichelate si 1 grilaj emailat [590x480x(H)55 mm dimensiuni interne]
- Termocuplu, aprindere electrica
- Furtunul de gaz si regulatorul de presiune sunt incluse
- Consum 0,8 m<sup>3</sup>/h
- Cu polita inferioara si 4 roti pentru deplasare usoara

cod	kW(H/S)	mm	lei
154908	22	1330x600x(H)920	2499,00



### TAVA EMAILATA

- Dimensiuni interioare 590x480 mm

cod	mm	lei
154656	590x480x(H)55	369,99



## PAELLA

18/0  
stainless steel



146002



Arzatorul poate fi scos  
pentru o curatare usoara



146804

### FIESTA 600

- Baza din otel inoxidabil si tigaie paella cu diametru 600 mm din tabla de otel
- Contine furtun de gaz, aprindere electronica si regulator de presiune
- Cu termocuplu si un arzator rotund
- Unitatea de ardere poate fi indepartata pentru o curatare usoara
- Spatiul de sub arzator este potrivit pentru butelii de gaz de 5 sau 6 kg
- Potrivit pentru propan gaz, consum 334 g/h

cod	kW(HS)	mm	lei
146002	4.8	600x600x(H)870	3749,00

### FIESTA 800

- Baza din otel cinoxidabil si tigaie paella cu diametru 800 mm din tabla de otel
- Contine furtun de gaz, aprindere electronica si regulator de presiune
- Cu termocuplu si un arzator rotund
- Unitatea de ardere poate fi indepartata pentru o curatare usoara
- Spatiul de sub arzator este potrivit pentru butelii de gaz de 5 sau 11 kg
- Potrivit pentru propan gaz, consum 489 g/h

cod	kW(HS)	mm	lei
146804	7	800x800x(H)900	4399,00

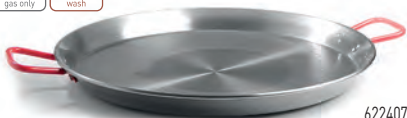

622407

### TIGAIIE PAELLA

- Tigaie din tabla de otel de inalta calitate
- Cu doua manere

cod	potrivita pentru grill gaz	mm	lei
622100		ø340x(H)40	49,99
622308		ø460x(H)40	88,99
622407	Fiesta 146002	ø600x(H)40	174,99
622605	Fiesta 146804	ø800x(H)50	394,99

### SORT PENTRU GRATAR

- Panza 280 gr/m<sup>2</sup>
- Strat ignifug

cod	mm	lei
556696	810x660	63,99

556696





700044

## GRATAR PE GAZ TAMPA NEGRU, 10 KW

- Gratarul Tampa are proprietati excelente de gatire, datorita proprietatilor sale de distributie eficienta a caldurii si circulatiei aerului cald in interiorul camerei de ardere
- Temperatura ridicata gateste carnea in mod uniform si rapid, reducand riscul lipirii carnii de suprafata de gatire
- Ansamblul arzatorului este fabricat in intregime din otel inoxidabil si poate fi dezasamblat complet pentru o curatare usoara.
- Arzatorul unic pe lungime este reglabil, are termocuplu de securitate si aprindere piezoelectrica.
- Inferno are un cadru acoperit in intregime cu vopsea epoxidica neagra, si dispune de patru roti, dintre care doua sunt roti pivotante, dar si de un sistem de siguranta pentru gaz
- Grasimea care se scurge din carne in timpul gatirii este colectata si directionata spre un recipient pentru grasime.
- Datorita suportului adanc pentru butelia de gaz, puteti plasa butelia de gaz in siguranta sub gratar.
- Suprafata gratarului: 1022 x 500 mm.

cod	kW[HS]	mm	lei
700044	10	1260x580x(H)900	8999,00



## XENON PRO

- Acest powergrill din otel inoxidabil cu baza pliabila din crom este usor de transportat datorita rotilor sale si poate fi ambalat intr-o unitate compacta in timpul transportului
- Arzatorul dezvolta o temperatura ridicata in unitatea superioara si, prin urmare, acest gratar este destinat unui volum mare de lucru
- Unitatea in sine este usor de curatat datorita acestor temperaturi ridicate
- Gratarul este echipat cu termocuplu si aprindere electronica, furtunul de gaz si regulatorul de presiune sunt incluse
- Potrivit pentru propan gaz
- Dimensiuni gratar 860x260 mm (2 x 430x260 mm)
- Baza rabatabila si mobila
- Consum 536 g/h

cod	kW[HS]	mm	lei
148105	7.5	1120x410x(H)900	2309,00



148105



**NOU**

148624

**XANTOS GRATAR PE GAZ**

- Acest gratar din otel inoxidabil are 4 picioare detasabile care pot fi impachetate intr-o unitate compacta pentru transport.
- Arzatoarele dezvolta o temperatura ridicata in unitatea rezistenta la vant si de aceea acest gratar este potrivit pentru productie de volum mare.
- Unitatea in sine este usor de curatat datorita acestor temperaturi ridicate.
- Cele doua arzatoare pot fi actionate independent.
- Echipat cu termocuplu si aprindere electrica, furtun de gaz si regulator de presiune sunt incluse.
- Potrivit pentru gaz propan.
- Suprafata grilei 540x540 mm (2 grile de 540x270 mm).

cod	kW[HS]	mm	lei
148624	9.5	770x710x(H)870	2809,00

**NOU**

148631

**XANTOS BLACK GRATAR PE GAZ**

- Acest gratar din otel inoxidabil are 4 picioare detasabile care pot fi impachetate intr-o unitate compacta pentru transport.
- Arzatoarele dezvolta o temperatura ridicata in unitatea rezistenta la vant si de aceea acest gratar este potrivit pentru productie de volum mare.
- Unitatea in sine este usor de curatat datorita acestor temperaturi ridicate.
- Cele doua arzatoare pot fi actionate independent.
- Echipat cu termocuplu si aprindere electrica, furtun de gaz si regulator de presiune sunt incluse.
- Potrivit pentru gaz propan.
- Suprafata grilei 540x540 mm (2 grile de 540x270 mm).
- Carcasa principala a arzatoarelor este emailata in negru.
- Panoul frontal si picioare vopsite cu pulbere neagra.
- Carcasa principala a arzatoarelor este emailata in negru.
- Panoul frontal si picioare vopsite cu pulbere neagra.

cod	kW[HS]	mm	lei
148631	9.5	770x710x(H)870	2459,00



## MANUSI

- Manusile de protecție HENDI sunt echipamente de protecție personală certificate și sunt conforme cu cerințele REGULAMENTULUI PARLAMENTULUI EUROPEAN ȘI ale CONSILIILUI (UE) 2016/425 din 9 martie 2016 privind echipamentul personal de protecție și abrogând Directiva Consiliului 89/686/CEE. Regulamentul specifică categoriile de pericole de la I la III. Pentru fiecare categorie au fost specificate metode și cerințe legate de certificare. Manusile de protecție HENDI sunt echipamente de protecție de categoria II.
- Acestea poartă marcajul CE ca echipament de protecție personală certificat.
- Toate manusile noastre îndeplinesc cerințele standardului general EN 420 Cerințe generale pentru manusi
- Acestea asigură:
  - protecție termică în conformitate cu EN 407 Manusi de protecție și alte echipamente de protecție a mâinilor împotriva riscurilor termice (caldura și/sau foc) și

- protecție împotriva pericolelor mecanice în conformitate cu EN 388 Manusi de protecție împotriva riscurilor mecanice și în conformitate cu EN 13997 Îmbracaminte de protecție - Proprietăți mecanice
- Determinarea rezistenței la tăiere cu un obiect ascuțit ascuțit.



11 XXXX

Protecție împotriva pericolelor termice au o pictogramă și cifre care specifică gradul de protecție asigurat, de ex.:

- primul număr descrie rezistența la foc, al doilea este rezistența la căldura de contact, al treilea este rezistența la căldura de convecție și a patra rezistența la căldura rezistentă la radiații, a cincea rezistență minoră la stropire cu metal topit, a șasea rezistență la cantități mari de metal topit.



### MANUSI PENTRU BARBECUE REZISTENTE LA CALDURA - 2 BUC.

- Rezistente la căldura până la 250 °C.
- Confortabile.

cod	ambalat pe	mm	lei
556634	2	(L)300	74,99



556634

### MANUSI PENTRU BARBECUE DIN PIELE REZISTENTE LA CALDURA - 2 BUC.

- Rezistente la temperaturi până la 250 °C timp de 10 secunde.
- Fabricat din piele de vacă.
- Lungi, pentru a proteja antebrațul.

cod	ambalat pe	mm	lei
556689	2	(L)460	119,99



556689

### MANUSI DIN PIELE REZISTENTE LA CALDURA PENTRU GRATAR - 2 BUC.

- Rezistente la căldura până la 250 °C.
- Fabricat din piele de vacă.
- Lungi, pentru a proteja antebrațul.

cod	ambalat pe	mm	lei
556658	2	(L)460	105,99



556658



## GRATARE CARBUNI

- Otel inoxidabil 18/10 cu suport detasabil



150603



150801

## GRATAR CU CARBUNI PATIO

- Echipat cu 2 gratare de 345x345 mm fiecare.
- Dimensiuni interioare: 710x350x(H)max.110 mm
- Recipient de cenusa cu baza dubla

cod	mm	lei
150603	770x380x(H)760	759,99

## GRATAR CARBUNI RESTO

- Echipat cu 3 gratare de 345x345 mm fiecare

cod	mm	lei
150801	1145x380x(H)770	949,99

## CARBUNE MARABU

- Destinat utilizarii in unitati profesionale de catering.
- Pentru prepararea la gratar a carnilor, pestelui, fructelor de mare, legumelor si aperitivelor.
- Produs prin carbonizarea lemnului de esenta tare la temperaturi cuprinse intre 400 si 700°C, fara aer.
- Realizat din planta invaziva de marabou, care creste in Cuba - align prima procurata responsabil, pentru productie ecologica. 100% natural.
- Fumul provenit din arderea acestui tip de lemn ofera preparatelor o aroma unica.
- Utere calorica mare, nivel scazut de scantei.
- Timp de ardere dublu, in comparatie cu tipurile de carbune moale utilizate in mod obisnuit.

cod	kg	lei
199541	10	143,99



199541



## BUCATI LEMN

- Destinate utilizării la temperaturi medii și mari.
- Ideal pentru cuptoare de pizza, cuptoare de exterior și gratare - plasare direct pe carbunele încins.
- Aroma unică
- Amplifică gustul preparatelor dvs.
- Fabricat din lemn natural de cea mai bună calitate sau din lemnul provenit de la butoaie de maturare. Oferta noastră include aschii realizate din lemn provenit de la butoaie în care s-a maturat vin, whisky sau coniac. - lemn de fag, maslin, citrice, migdal sau lemn de piersic



PIERSICA

cod 199503  
greutate 3 kg  
lei 100,99



FAG

cod 199459  
greutate 3 kg  
lei 100,99



CITRICE

cod 199480  
greutate 3 kg  
lei 100,99



STEJAR

cod 199466  
greutate 3 kg  
lei 100,99



MIGDAL

cod 199497  
greutate 3 kg  
lei 100,99



MASLIN

cod 199473  
greutate 3 kg  
lei 100,99



VIN ROSU

cod 199510  
greutate 3 kg  
lei 100,99



COGNAC

cod 199534  
greutate 3 kg  
lei 100,99



WHISKEY

cod 199527  
greutate 3 kg  
lei 100,99





525524



525531

525555

**SET PERII DE SARMA INGUSTE - 3 BUCATI**

- Set de 3 perii inguste de sarma.
- Setul este format din perie cu perii din otel inoxidabil, una cu peri de alama si una cu peri din nailon.

cod	ambalat pe	mm	lei
525524	3	(L)178	19,99
525531	3	(L)230	20,99

**SET DE PERII DIN ALAMA & DIN OTEL INOXIDABIL - 2 BUCATI**

- Set de 2 perii de sarma diferite cu 4 randuri de 14 fire.
- Setul este format dintr-o perie cu fire din otel inoxidabil si una cu peri din alama.

cod	ambalat pe	mm	lei
525555	2	(L)290	32,99



525548

**PERIE SARMA**

- Polipropilena cu 8 randuri de 8 fire din otel inoxidabil.
- Cu racleta din otel si maner lung.

cod	mm	lei
525548	70x310x(H)85	20,99



525425

525432

**PERIE DE SARMA IN FORMA DE Y**

- Peri din otel inoxidabil, cu maner confortabil, prevazut cu o bucla

cod	mm	lei
525425	310x170	15,99
525432	520x170	32,99



525562

**PERIE SARMA**

- Maner din plastic negru confortabil cu fire de otel.

cod	mm	lei
525562	150x55	15,99



525418

**PERIE SARMA**

- Polipropilena cu 8 randuri de 9 fire din otel inoxidabil.
- Racleta de otel pentru gratar.

cod	mm	lei
525418	70x200x(H)80	12,99



525517

**PERIE SARMA - 2 BUCATI**

- Lemn cu 4 randuri de fire sarma

cod	ambalat pe	mm	lei
525517	2	(L)290	20,99



855201

**RACLETA GRATAR**

cod	mm	lei
855201	100x320	59,99



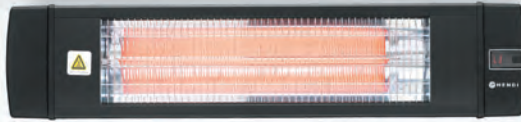

272428

### INCALZITOR TERASA PATIO CU INFRAROSU

- Adecvat pentru incalzirea teraselor in zilele reci.
- Puternic - va asigura confortul oaspetilor chiar si atunci cand temperatura este scazuta.
- Conceput pentru montare pe perete, poate incalzi o zona de la aproximativ 16 la 32 m<sup>2</sup>.
- Lampa de incalzire utilizeaza fibra de carbon moderna, care se traduce prin o durata de viata mai lunga si o eficienta ridicata la incalzire, cu consum redus de energie.
- Carcasa robusta cu grila de protectie din aluminiu rezistent la caldura.
- Furnizat cu telecomanda pentru reglarea facila a setarilor.
- Puteti alege intre 4 niveluri de putere de incalzire.
- Cu cronometru incorporat pentru pana la 25 de ore.



cod	V	W	mm	lei
272428	230	2500	912x185x(H)174	849,99



### INCALZITOR TERASA

- Potrivit pentru gaz propan sau butan, recipiente de max. 15 litri
- Design compact, usa cu balamale pentru inlocuirea usoara a buteliei de gaz
- Comutator pentru inclinare, dispozitiv de siguranta la aprindere si protectie flacara pentru siguranta sporita
- Include aprindere electronica, furtun de gaz si regulator de presiune
- Usor de transportat datorita celor 2 roti cu care este echipat

cod	kW(HS)	mm	lei
272411	8.5	ø556x(H)1430	1339,00
144954	Husa protectie	ø580x(H)1460	83,99



272411

Husa de protectie -  
se va comanda separat

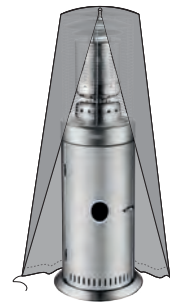

144954

## INCALZITOR TERASA PATIO



272602



Usor de transportat datorita celor 2 roti



Inclusiv aprinderea electronica, furtunul de gaz si regulatorul de presiune



Lampa reglabila pe inaltime - model 272701

272701

### INCALZITOR TERASA

- Potrivit pentru gaz propan sau butan.
- Usor de transportat datorita celor 2 roti.
- Contine aprindere electronica, furtun de gaz si regulator de presiune.
- Cu protectie anti-inclinare.

cod	kW[HS]	mm	lei
272602	12.5	ø770x(H)2200	1049,00

### INCALZITOR TERASA - RETRACTABIL

- Potrivit pentru gaz propan sau butan
- Usor de transportat datorita celor 2 roti
- Arbore retractabil pentru usurinta transport si depozitare
- Contine aprindere electronica, furtun de gaz si regulator de presiune
- Cu protectie anti-inclinare

cod	kW[HS]	mm	lei
272701	12.5	ø770x(H)1580	1099,00



Husa de protectie -  
se va comanda separat



144909



### INCALZITOR TERASA PYRAMID

- Incalzire cu flacara reala intr-un tub de sticla, imbunatateste atmosfera
- Structura din aluminiu cu panouri laterale din metal negru si tub de sticla de cuar
- Rezervorul de gaz se potriveste in baza
- Include aprindere electronica, furtun de gaz si regulator de presiune
- Cu protectie anti-inclinare
- Potrivit pentru propan sau butan gaz

cod	kW[HS]	mm	lei
272404	11.2	500x500x(H)2220	2079,00
144909	Husa protectie	480x480x(H)2220	116,99



272404



<b>SELGROS BUCURESTI BANEASA</b>	Brasov	Calea Bucuresti nr. 231, 500299 e-mail: 341_PR_Group@selgros.ro tel. 0268.307.000
<b>SELGROS BUCURESTI BANEASA</b>	Bucuresti, Ilfov	Soseaua Bucuresti - Ploiesti nr. 55-56, sector 1, 715811 e-mail: 342_PR_Group@selgros.ro tel. 0213.078.000
<b>SELGROS BUCURESTI PANTELIMON</b>	Bucuresti- -Pantelimon, Ilfov	Bulevardul Biruintei nr. 90 739571 e-mail: 343_PR_Group@selgros.ro tel. 0212.093.000
<b>SELGROS MURES ERNEI</b>	Tirgu Mures, Mures	Comuna Ernei nr. 591, 547215 e-mail: 344_PR_Group@selgros.ro tel. 0265.205.000
<b>SELGROS BUCURESTI BERCENI</b>	Bucuresti, Ilfov	Str.Turnu Magurele nr. 92 - 108, 755461 e-mail: 345_PR_Group@selgros.ro tel. 0214.068.000
<b>SELGROS CONSTANTA SUD</b>	Agiea, Constanta	Str. Dravos Voda nr. 1 - Sat Lazu - Com. Agiea, 907016 e-mail: 346_PR_Group@selgros.ro tel. 0241.706.000
<b>SELGROS CRAIOVA</b>	Craiova, Dolj	sat Preajba, com. Malu Mare, str. Henry Ford nr. 12, 207367 e-mail: 347_PR_Group@selgros.ro tel. 0251.305.000
<b>SELGROS TIMISOARA</b>	Timisoara, Timis	Calea Aradului nr. 64, 300291 e-mail: 348_PR_Group@selgros.ro tel. 0256.279.000
<b>SELGROS ORADEA</b>	Oradea, Bihor	str. Ogorului nr. 65 B, 410554 e-mail: 349_PR_Group@selgros.ro tel. 0259.405.000
<b>SELGROS CLUJ-NAPOCA</b>	Cluj-Napoca, Cluj	str. Calea Someseni nr. 8, 99999 e-mail: 350_PR_Group@selgros.ro tel. 0264.503.000
<b>SELGROS ARAD</b>	Arad	str. Calea Radnei nr. 294, 310318 e-mail: 351_PR_Group@selgros.ro tel. 0257.308.000
<b>SELGROS PLOIESTI</b>	Ploiesti, Prahova	Sat Blejoi, comuna Blejoi, nr.1190, 107070 e-mail: 352_PR_Group@selgros.ro tel. 0244.502.000

<b>SELGROS BACAU</b>	Bacau	Prelungirea Bradului nr. 135B, 600367 e-mail: 353_PR_Group@selgros.ro tel. 0234.209.000
<b>SELGROS SUCEAVA</b>	Suceava	Str. Cernauti nr.118, 720089 e-mail: 354_PR_Group@selgros.ro tel. 0230.553.000
<b>SELGROS IASI</b>	Iasi, Iasi	Soseaua Nicolina nr. 57A, 700711 e-mail: 355_PR_Group@selgros.ro tel. 0232.306.000
<b>SELGROS GALATI</b>	Galati	Bd. Galati nr. 1C, 800654 e-mail: 356_PR_Group@selgros.ro tel. 0236.305.000
<b>SELGROS BRAILA</b>	Braila	Str. Ramnicu Sarat, nr. 92 B, 81016 e-mail: 357_PR_Group@selgros.ro tel. 0239.602.000
<b>SELGROS BUCURESTI DRUMUL TABEREI</b>	Bucuresti, Ilfov	Str. Valea Cascadelor, nr.26B, sector 6, 61515 e-mail: 358_PR_Group@selgros.ro tel. 0212.258.000
<b>SELGROS CONSTANTA NORD</b>	Constanta	B-dul Tomis, nr. 387, 900497 e-mail: 359_PR_Group@selgros.ro tel. 0241.684.000
<b>SELGROS TARGU MURES</b>	Tirgu Mures	Str. Gheorghe Doja nr. 62, 40146 e-mail: 361_PR_Group@selgros.ro tel. 0265.203.000
<b>SELGROS ALBA IULIA</b>	Alba Iulia	B-dul Republicii nr. 30A , 10174 e-mail: 362_PR_Group@selgros.ro tel. 0258.802.000
<b>SELGROS BISTRITA</b>	Bistrita Nasad	Calea Moldovei nr. 13B, 20101 e-mail: 363_PR_Group@selgros.ro tel. 0263.202.000
<b>SELGROS BAIA MARE</b>	Baia Mare, Maramures	B-dul Bucuresti nr.102, 30013 e-mail: 364_PR_Group@selgros.ro tel. 0262.201.000





SMART HORECA SOLUTIONS

**SMART HORECA SOLUTIONS SRL**

Strada Artelor nr. 1  
Cluj, Chinteni  
tel.: 0753.512.997  
e-mail: mihal.smarthoreca@yahoo.com



**HORECA EXPRESS INTERNATIONAL SRL**

Strada Cernavoda 5-9  
Cluj Napoca  
tel.: 0732.988.575  
e-mail: office@horecaexpress.ro



**GYM INVEST S.R.L.**

Strada Principala nr. 3M  
Salaj, Zalau - Sat Panic  
tel.: 0747.271.210  
e-mail: gimihome@gmail.com



**SAT AN IMPEX SRL**

Strada Careiului nr. 67  
Satu Mare  
tel.: 0744.774.303  
e-mail: robert@practic-electrocasnice.ro



**GRUP GENERAL ID S.R.L.**

Bulevardul Independentei 134  
Baia Mare  
tel.: 0733021902  
e-mail: vanzari@grupgeneralid.ro



**P & D POLIDOM PRODUCTIE SRL**

Strada Morilor nr. 68  
Iasi  
tel.: 0723.178.469  
e-mail: office@polidomservice.ro



**ROXMAR HORECA S.R.L.**

Strada Visinilor nr, 57, bloc 52  
Suceava  
tel.: 0721.363.908  
e-mail: roxmarhoreca1974@gmail.com

**OVAVINCI S.R.L.**

Str. Grigore Alexandru 12a  
Suceava  
tel.: 0746 861 158  
e-mail: mihaela\_ovadiuc@ovavinci.ro



**CROWN COOL S.R.L.**

Strada Toplita nr. 155  
Harghita, Miercurea Ciuc  
tel.: 0266.317.827 / 0726.308.900  
e-mail: office@tcromania.ro



**GASTRO EXPERT PROFIS SRL**

Str. Livezeni 4  
Mures, Targu Mures  
tel.: 0722.327.972  
e-mail: office@gastroexpert.ro



**OFFICE PROD SIB S.R.L.**

Strada Florea Stanculescu nr. 9  
Sibiu, Cisnadie  
tel.: 0748.593.079  
e-mail: office@prodsib.ro



**AUTO CENTER SIBIU SRL**

Strada Henri Coanda nr. 12  
Sibiu  
tel.: 0752.601.561  
e-mail: office@gastrotehnice.ro



**CLANISA WEBFLUENCE S.R.L.**

Str. Albatrosului, nr. 9  
Brasov  
tel.: 0746803744  
e-mail: contact@loria.ro

**OSHO INDUSTRY S.R.L.**

Str. Zizinului 109 Bis  
500407 Brasov  
tel.: 0757 407 407  
e-mail: osho.industry@gmail.com





**BVG CONSULTING VISION SRL**

Strada Automatizarii nr. 8 , ap. 5 , sector 1  
Ilfov, Bucuresti  
tel.: 0756.022.630  
e-mail: vlad.butoiu@gmail.com

**JUST TOP OFFICE S.R.L.**

Soseaua Oltenitei nr. 103  
Ilfov, Bucuresti  
tel.: 0775.256.136  
e-mail: contact@justtopoffice.ro

**HORECA TOTAL SOLUTIONS 94 S.R.L.**

Strada Depozitului nr. 35  
Bucuresti  
tel.: 0734.506.917  
e-mail: horecatotalsolutions94@yahoo.com

**RESSTO MANAGEMENT GRUP S.R.L.**

Bragadiru, str. Lacramioarelor 11  
Ilfov  
e-mail: admin@ressto.ro



**MICUL MESERIAS CONCEPT S.R.L.**

Bd. Voluntari 106  
Voluntari, Ilfov  
tel.: 0370-509-006  
e-mail: contact@micul-meserias.ro



**CLEVER SERVICES S.R.L.**

Calea Bucuresti, nr. 41K  
077185 Comuna Vidra, Judet Ilfov  
tel.: 0723382468  
e-mail: XXXX



**CIS GAZ SA**

Strada Petre S. Aurelian nr 62  
N15, Sector 1, Bucuresti  
tel.: 0265 313 018  
e-mail: office@cisgaz.com



**SC NORDICA S.R.L.**

Jud. cluj, mun. dej, str. fragilor, nr.1, bl.t6, ap.30  
tel.: 0264 211 480

REGIUNE SUD-EST - CONSTANTA, TULCEA, BRAILA, GALATI

**REGENCY PROJECT SRL**

Bulevardul Mamaia nr. 284

Constanta

tel.: 0771.236.943

e-mail: office@regencyproject.ro

REGIUNE SUD - BUCURESTI (SECTOR 3, SECTOR 4), DAMBOVITA, IALOMITA, CALARASI



**HORECA SOLUTION SRL**

Strada Amurgului nr. 33K

Ilfov, Popesti Leordeni

tel.: 0749.996.384

e-mail: office@coffeemarket.ro

**NEXT CLEAN S.R.L.**

Aleea CICEU, nr. 4

Sector 4, Bucuresti

tel.: 0773304289

e-mail: office@nextclean.ro

**NOVLARI S.R.L.**

Jud. Vrancea, Sat Paunesti,

Magazin Universal, Etaj II

tel.: 0766 544 904

REGIUNE SUD - BUCURESTI (SECTOR 1, SECTOR 5), PRAHOVA, TELEORMAN, GIURGIU



**WEB COFFEE S.R.L.**

Strada Negoiu nr. 41

Bucuresti

tel.: 0722.116.266

e-mail: office@webcoffee.ro



**SUPORT HORECA SRL**

Strada Aricultori 113, corp 2, et. 1, lot 2

Bucuresti

tel.: 0722.199.463

e-mail: office@horecamag.ro



**FRESCO EXPERT SRL**

Strada Oxigenului 1H, Hala 4  
Ilfov, Caldararu-Cernica  
tel.: 021.252.10.59  
e-mail: office@fresco.ro

**ENTRAD PARTNERS SRL**

Soseaua Bucuresti-Ploiesti nr. 24  
Ilfov, Petresti, Comuna Corbeanca  
tel.: 0756.825.698  
e-mail: alexandra@horecaoutlet.ro

**HORECA & RETAIL FOOD SOLUTIONS SRL**

Calea Bucuresti nr. 13  
Ilfov, Saftica  
tel.: 0762.028.400  
e-mail: horeca.retail@gmail.com



**HOUSE HOLD ELECTRO COMPANY SRL**

Soseaua Colentina nr. 301 C  
Bucuresti  
tel.: 0723.341.927  
e-mail: rahman1991@gmail.com



**GROSS METAL HORECA S.R.L.**

Strada Victoriei nr. 332  
Gorj, Tirgu-Jiu  
tel.: 0744.399.600  
e-mail: gmproffequip@gmail.com



**SIDE GRUP S.R.L.**

Strada Felnac nr. 1000  
Arad, Sat Felnac  
tel.: 0728.886.567  
e-mail: o.david@side.ro



**DIRECA DEPO SRL**

Strada Depozitului nr. 35  
Bihor, Oradea  
tel.: 0359.450.777  
e-mail: contact@direca.ro

**BOGMAR S.R.L**

Strada Pop Sapca nr. 35  
Valcea, Ramnicu-Valcea  
tel.: 0745.752.386  
e-mail: office@bogmar.ro



**CENTRO GROUP PROFESIONAL TM SRL**

Strada Carpati nr. 11  
Timis, Mosnita Noua  
tel.: 0256.393.626 / 0741.002.095  
e-mail: contact@centrogroup.ro



**CALLAS SERV S.R.L.**

Strada Henri Coanda nr. 19, Bl.PB. 19, Ap. 5  
Bihor, Oradea  
tel.: 0770.105.657  
e-mail: callas.serv@gmail.com

**HORECA PROLAB S.R.L.**

Str. Piatra Craiului Nr. 8  
Oradea, Bihor



**SIDE TRADING S.R.L.**

Str. Hamilton nr. 1-3  
307210, Giarmata, Timis  
tel.: 0256 285 641  
e-mail: office@sidetrading.ro



**COMPUTERLINE S.R.L.**

Bd. Corvin 11  
331005, Hunedoara  
tel.: 0354 405 455  
e-mail: office@computer-line.ro



**PRO HORECA S.R.L.**

Str. Piatra Craiului Nr. 8  
Oradea, Bihor  
tel.: 0724 408 044  
e-mail: office@pro-horeca.ro



**SLAVA HOME S.R.L.**

Calea campulung Nr. 1d  
110147 Oradea, Pitesti  
tel.: 0742032208  
e-mail: comenzionline@slava.ro





<b>METRO TIMISOARA 1</b>	Timisoara	Timisoara Calea Sagului (DN 59, Km 8), 300221 tel.: 0374 115 555; 0256290770
<b>METRO TIMISOARA 2</b>	Timisoara	Calea Torontalului, DN6, km 5+600, Timisoara, 300668 tel.: 0374 115 555; 0256250150
<b>METRO CONSTANȚA 1</b>	Constanta	Bd. Aurel Vlaicu nr.237, 900498 tel.: 0374 115 555; 0241640700
<b>METRO CONSTANȚA 2</b>	Constanta	Sos. Mangaliei nr. 211 , Constanța , 900082 tel.: 0374 115 555; 0241702195
<b>METRO BRASOV 1</b>	Brasov	Ghimbav, Calea Brasovului, NR. 9., Brasov, 507075 tel.: 0374 115 555; 0268258430
<b>METRO BRASOV 2</b>	Brasov	Calea Bucuresti, jud. Brasov, 233, Brasov, 500299 tel.: 0374 115 555; 0268303195
<b>METRO ARAD</b>	Arad	Sos. Calea Zimandului, 43C, Arad, 310208 tel.: 0374 115 555; 0374561113
<b>METRO BACAU</b>	Bacau	Sos. DN 2 (Bacau-Focsani), Nicolae Balcescu, 607355 tel.: 0374 115 555; 0234203150
<b>METRO BAIA MARE</b>	Baia Mare	DN1C, B-dul Independenței, km 155, jud. Maramures, Baia Mare, 430071 tel.: 0374 115 555; 0262202150
<b>METRO BERCENI</b>	Bucuresti	Bd. Metalurgiei 130 A, sector 4, Bucuresti, 041837 tel.: 0374 115 555; 0214066160

<b>METRO MILITARI</b>	Bucuresti	Bd. Iuliu Maniu 500, sector 6, Bucuresti Bucuresti, 061128 tel.: 0374 115 555; 0214023150
<b>METRO BANEASA</b>	Bucuresti	Sos. Bucuresti-Ploiesti 44D, Bucuresti, 013696 tel.: 0374 115 555; 0212003195
<b>METRO VOLUNTARI</b>	Bucuresti	Bulevardul Voluntari,, nr.104, Voluntari, 077190 tel.: 0374 115 555; 0212703793
<b>METRO PALLADY</b>	Bucuresti	Bdul Theodor Pallady nr. 51, Bucuresti, 32258 tel.: 0374 115 555; 0216444150
<b>METRO BUZAU</b>	Buzau	Str. Transilvaniei Nr.441A, Buzau, Buzau, 120164 tel.: 0374 115 555; 0374205632
<b>METRO CLUJ</b>	Cluj	Loc. Floresti, Str. Avram Iancu 488-490, Cluj, 407280 tel.: 0374 115 555; 0264591000
<b>METRO CRAIOVA</b>	Craiova	Calea Bucuresti, Km 7.5, com. Carcea, Jud. Dolj, Craiova, 061128 tel.: 0374 115 555; 0251403150
<b>METRO DEVA</b>	Deva	Calea Zarandului, nr. 87, Deva, 330182 tel.: 0374 115 555; 0254202101
<b>METRO GALATI</b>	Galati	DN 26, Galați - Tg. Bujor, Loc. Vanatori, km 5, Costi, 807326 tel.: 0374 115 555; 0236302150
<b>METRO IASI</b>	Iasi	DN 26, Galați - Tg. Bujor, Loc. Vanatori, km 5, Costi, 807326 tel.: 0374 115 555; 0232202150



distribuito

[www.hendi.ro](http://www.hendi.ro)